

Single & Dual Thermocouple Wireless Temperature Transceiver Node

Wireless
Temperature

Phase IV Data Sheet Leap Sensors® Single & Dual Thermocouple Node

Applications

- Extreme temperature monitoring
- Make any type of off-the-shelf thermocouple wireless
- Ideal for in-process monitoring, equipment monitoring, general plant health monitoring, and operational threshold temperature tracking

Special Features

- Sensor transmission range of 1,500 ft. in open air
- Node is configurable to power and transmit any thermocouple type - K, J, T, N, S, E, B, R
- Each thermocouple is electrically isolated
- Edge computing gives small, actionable data.
- Configurable sample and transmit intervals to fit many application requirements.
- Simple integration into existing Leap Sensor systems
- Transceiver nodes are factory preconfigured to pair with new or existing gateway for simple integration – up and running in 5 minutes.
- LED indicators on transceiver node for power, network connection, gateway connection, and database connection statuses.

Description & Product Highlights

Phase IV's Leap Sensors Thermocouple Transceiver Node is ideal for any remote temperature monitoring application. Any thermocouple type can be configured to be compatible. User-configurable sample and transmit rates, as well as event-triggered rapid sampling conditions, give the user powerful insight to prevent failure conditions based on operating temperature.

The Leap Sensors wireless sensor system greatly reduces the cost and complexity of laying cables between sensors and data acquisition units. Wireless communication is much better suited for small, actionable data to trigger alerts.

Dual isolated thermocouple circuits eliminate the risk of ground loops occurring between two monitoring points, as well as reduces the induced noise in each sensor signal.

The Leap Sensors system is intended primarily for the purpose of performing industrial sensor measurements.



Single & Dual Thermocouple Node Model (Dual Shown)

Modularity and customizability

Each Thermocouple Temperature Transceiver Node has the capability to support and interface simultaneously with two thermocouple sensors of any type. In addition, semi-custom solutions can be created leveraging our multi-sensor base board to expand sensor interfacing capabilities.

Ease of implementation

All Leap transceiver nodes come pre-configured and paired with selected Leap Sensors gateways for quick and simple integration into an existing Leap Sensors gateway system, or to function as a new stand-alone system. Custom firmware loaded on the device can configure the data viewing software to accept any and all new device types.

Real-time data viewing and alters

All Leap Sensors nodes stream data to Leap Sensors gateway devices at configurable intervals. This data is accessible and viewable in real time. In addition to real-time viewing and graphing of sensor parameters, alerts based on any sensor condition are configurable, and can be sent via phone call, email, or text for instant communication of a sensor reaching an alert condition.

Leap Sensors® Single & Dual Thermocouple Node Specifications		
General Sensor Specifications		
Analog Input Signals	Thermocouple Chip: 2 X isolated thermocouple inputs	
Supplied Sensors	Contact factory for configurable thermocouple options.	
Enclosure Connectors	Pre-configured cable gland, or female mini bladed thermocouple connector	
Output Units	Temperature in C, K, F, R	
Integrated Temperature Chip (Cold Junction Compensation)		
Chip Specifications	+0.0625 °C resolution, open and short circuit detection	
Compatible Thermocouple Types	K, J, T, N, S, E, B, R	
Accuracy	+/- 0.5 °C (typical) for the circuit	
Power Specifications		
Battery Power	3.6 V, 14,000 mAh D-cell, lithium thionyl chloride	
Battery Life	6-8 years at 10 minute transmit & sample intervals On-board battery passivation prevention circuit assures long life	
Power / Current Consumption	Low sleep current assures long life Typical Operating Current: 6mA - 30mA (depending on sensors) Typical Transmit Current: 9mA @ 0dBm and 80mA @ 20 dBm RX Current: 11 mA	
Wireless Specifications		
Wireless Transmission Range	Industrial Environments*	Open-Air*
	500 ft	1,500 ft
Range Extenders	Range extenders available to extend transmission distance.	
RF Transmission Power	User configurable 0-20 dBm, factory configured to 20 dBm**	
RF Communication Protocol	Internet protocol-based Thread, IPV6LoWPAN, IEEE 802.15.4	
RF Frequency and Modulation	2.4 GHz (16 Channels), DSSS provides higher noise and interference resistance	
Data Security	AES 128-bit encryption with secure join and key exchange (J-PAKE)	
Other Features		
Operating Temp.	- 40 °C to 60 °C, -40°C to 120°C available – special order	
Gateway Compatibility	Compatible with all Leap Sensors® wireless gateways	
Firmware	Over-the-air upgradeable via web interface	
Certifications	FCC (USA), IC (Canada)	
Gateway Communication	Send and receive (data, acknowledgements, updates, and device configuration). Data stored in node until confirmed write to database.	
LED Power Switch	Recessed in the enclosure to prevent accidental power cycling. On-switch is recessed. Off-switch flush with surface. Immediately resets transceiver node when turned off. Integrated green and red LED indicate wireless connection status at power-up.	
Internal Memory	110,000 time-stamped device readings stored on transceiver node if gateway does not acknowledge writing data to database.	
Enclosure & Hardware Specifications		
Dimensions	113 mm x 80 mm x 60 mm	
Weight	355g typical for complete transceiver node	
Material	Polycarbonate (UL 94 rated and 120C rated)	
Mounting Options	Optional feet (shown in drawing) can be mounted horizontally or vertically. Screws can also be passed through the enclosure (when the lid is open) for mounting without feet.	
Ingress Protection	IP68 enclosure. IP67 glands, cables, switch	
Node Antenna	Internal antenna (typical). External antenna (optional)	

[Outbound sensor data, inbound device configurations, firmware updates, and transmission acknowledgements]

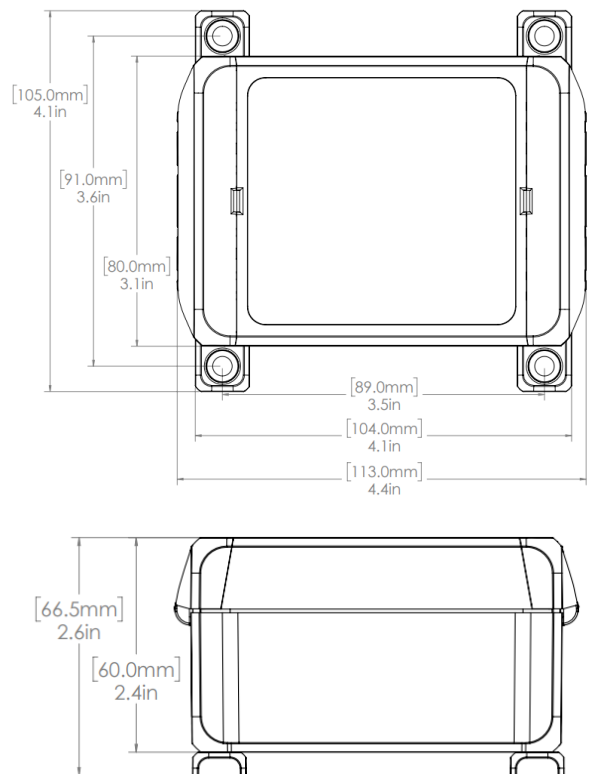
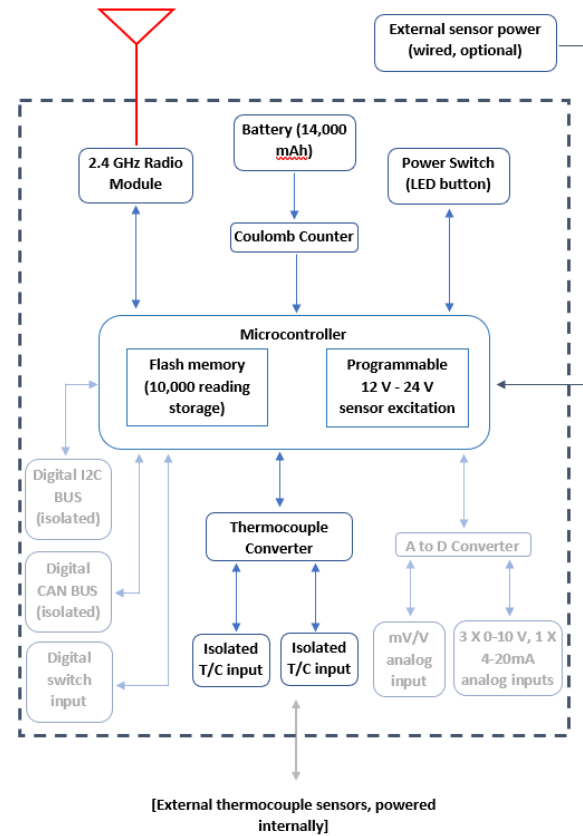

* Transmission ranges vary with environmental conditions. Reported values are test averages.
** Transmission power requirements are governed regionally.