

PH12 Series pH and ORP Sensors - Quick Start

Important Information

Read these instructions carefully and look at the equipment to become familiar with the device before trying to install, operate, service, or maintain it. The following special messages may appear throughout this manual or on the equipment to warn of potential hazards or to call attention to information that clarifies or simplifies a procedure.



The addition of either symbol to a “Danger” or “Warning” safety label indicates that an electrical hazard exists which will result in personal injury if the instructions are not followed.



This is the safety alert symbol. It is used to alert you to potential personal injury hazards. Obey all safety messages that follow this symbol to avoid possible injury or death.

DANGER

DANGER indicates a hazardous situation which, if not avoided, **will result in** death or serious injury.

WARNING

WARNING indicates a hazardous situation which, if not avoided, **could result in** death or serious injury.

CAUTION

CAUTION indicates a hazardous situation which, if not avoided, **could result in** minor or moderate injury.

NOTICE

NOTICE is used to address practices not related to physical injury.

Please Note

Electrical equipment should be installed, operated, and maintained only by qualified personnel. No responsibility is assumed by Schneider Electric for any consequences arising out of the use of this material.

A qualified person is one who has skills and knowledge related to the construction, installation, and operation of electrical equipment and has received safety training to recognize and avoid the hazards involved.

Introduction

The PH12 Series pH and ORP Sensors are designed for use with Foxboro 875PH, 873PH, and 873DPX Analyzers and 876PH and 870ITPH Transmitters. Some can also be used with 873APH Analyzers and Analyzers of other companies. When used with an 875PH, 876PH, or 870ITPH, they provide the additional capability of on-line diagnostics to signal the user if any of several common sensor alerts occur.

Safety Considerations

WARNING

RISK OF EXPOSURE

When installing or removing sensors, wear appropriate protective clothing including protective goggles. Escaping chemicals under pressure can cause severe injury, including blindness.

Failure to follow these instructions can result in death or serious injury.

WARNING

RISK OF EXPOSURE

1. Use care when connecting and disconnecting high-pressure service connection. Use proper gloves and follow the recommended procedures to avoid severe injury to personnel or damage to equipment.

2. When processing hazardous liquids, follow the recommended procedures. Failure to do so could result in injury to personnel and damage to equipment.

3. Use only Foxboro replacement parts. Substitution parts could result in damage to equipment, damage to the process, and/or injury to personnel.

(Avoid exposing sensor for prolonged periods to dry atmospheres at elevated temperatures, as sensor lifetime may be reduced.)

4. In addition to the pressure and temperature limits of the sensor, the PH12 mounting accessories also have pressure and temperature limits. The specifications for the mounting accessories may be greater or less than the sensor specifications. Use the lesser of the two specification limits when designing the installation of PH12 sensors with accessories.

5. Due to differing thermal expansion coefficients, take care to match the material of piping and fitting to the mounting accessories.

Failure to follow these instructions can result in death or serious injury.

CAUTION

RISK OF GLASS BREAKAGE

To help prevent damage, use care when handling sensitive sensor components such as glass electrodes.

Failure to follow these instructions can result in injury or equipment damage.

Specifications

Measurement Range:

Domed Glass Electrode: 0 and 14 pH

Flat Glass Electrode: 0 and 12 pH

Platinum Electrode (ORP): The measurement range (mV) is limited only by the readout instrument.

Automatic Temperature Compensation (ATC) as specified:

100 Ω platinum RTD or

1000 Ω platinum RTD

— NOTE —

Both RTDs are 3-wire type to provide lead length compensation. They can be used with analyzers and transmitters that accept either 2- or 3-wire temperature elements. The PH12-****S version uses a 1000 ohm RTD; this sensor is compatible only with 876PH-S Series Transmitters.

Storage Temperature Limits: -5 and +65°C (23 and 149°F)

Process Pressure Normal Operating Conditions Limits: -48 and +1034 kPag (-7 and +150 psig)

Process Temperature Normal Operating Condition Limits:

pH Domed Glass (Wide Temp) Electrode: -25 and +125°C (-13 and +257°F)

pH Domed Glass (High Temp) Electrode: 0 and 140°C (32 and 284°F)

pH Flat Glass Electrode: -15 and +125°C (5 and 257°F)

Platinum ORP Electrode: -25 and +125°C (-13 and +257°F)

— NOTE —

Use pH temperature values for combination pH and platinum electrodes. High temperature limits are valid for intermittent service such as sterilization in a bioreactor. Continuous operation at the maximum temperatures, especially in aggressive solutions, may reduce sensor lifetime.

Sensor Materials:

Sensor Body: PEEK or Borosilicate Glass as specified

Measuring Electrode:

pH Measurement: Domed or flat glass

ORP Measurement: Platinum

Internal electrode is silver wire coated with silver chloride

Sensor Length: 120 mm (4.7 in), 225mm (8.9 in), 360 (14.2 in), and 425 mm (16.7 in)

Reference Electrode: Internal electrode is silver wire coated with silver chloride (inside a Nafion ion barrier)

Reference Junction: Ceramic

Solution Ground:

- ◆ pH or ORP Measurement: Conductive Kynar (nonmetallic), or stainless steel (option -S).
- ◆ pH/ORP Combination Measurement: Platinum

Process O-Ring and Process Electrode Seal: Viton is standard; EPDM and Perfluoroelastomer (FFKM) are optional.

Reference Solution: Gelled electrolyte

Thrust Washer: Glass filled (25%) ptfe

Accessory Materials:

- ◆ Holder or Process Connection: 316L ss, CPVC, or Kynar.
- ◆ Holder O-Ring: Viton (standard), or EPDM, Chemraz, Kalrez, or Perfluoroelastomer (FFKM).

Variopin Connector Protection Class: Meets the ingress protection of IEC IP66 and IP68 per IEC 60529. IP68 is at a depth of 2 m (6.6 ft) for 48 hours.

Sensor Mounting: Up to 90° from vertical with the electrode end downward.

Electromagnetic Compatibility (EMC):

When its cable is connected through rigid metal conduit as recommended for the 876PH, the pH12 Sensor complies with electromagnetic compatibility requirements of European EMC Directive 2014/30/EU by conforming to the following standards: EN 61326-1:2006, Electrical equipment for measurement, control and laboratory use - EMC requirements, Class A emission limits, and immunity requirements according to Table 2 for Industrial locations.

Electrical Safety Specifications (Analog Version Only):

The PH12 Sensor meets the requirements of a simple apparatus as defined below.

An electrical component or combination of components of simple construction with well-defined electrical parameters which does not generate more than 1.5 V, 100 mA, and 25 mW or a passive component which does not dissipate more than 1.3 W. Certification to the ATEX directive is not required because of the low levels of energy which are added to the intrinsically safe circuit by this apparatus. When connected to an intrinsically safe pH/ORP transmitter, such as a Model 876PH, the PH12 sensor can be installed in a Division 1 or Zone 0 hazardous area.

The following are examples of a simple apparatus:

- a. Passive components, for example, switches, junction boxes, resistance temperature devices, and simple semiconductor devices such as LEDs.
- b. Sources of generated energy, for example, thermocouples and photocells, which do not generate more than 1.5 V, 100 mA and 25 mW.

General Installation Guidelines

NOTE

Piping techniques must comply with standard and acceptable practices.

Proper mounting of the sensor is important for efficient and accurate operation.

For dimensional information, see DP 611-214.

For application and sensor configurations, mounting arrangements must be located so that:

- ◆ Sample at the sensing area is representative of the process solution.
- ◆ Solution circulates actively and continuously past the sensing area (electrodes must stay wetted.)
- ◆ Flow velocity at sensing area does not cause cavitation or electrode damage.
- ◆ Position and orientation of the sensor does not trap air bubbles within the sensing area.
- ◆ Orientation of the sensor is any position up to 90° from vertical with the electrode end downward.
- ◆ Accessibility for replacement is considered. A flow-type installation must have blocking valves (user supplied) to allow for sensor replacement.
- ◆ Deposits of sediment or other foreign material do not accumulate within the sensing area.
- ◆ Provision for removal of the sensor from the process is considered. If cable is installed in metal conduit (recommended), either use flexible conduit or make some other provision.

NOTICE

POTENTIAL EQUIPMENT DAMAGE

When installing a sensor, be careful not to bottom the sensor in the vessel, particularly in a small diameter pipe.

Failure to follow these instructions can result in equipment damage.

For detailed installation instructions, see MI 611-214.

Dimensions

Refer to DP 611-214.

Cable Length

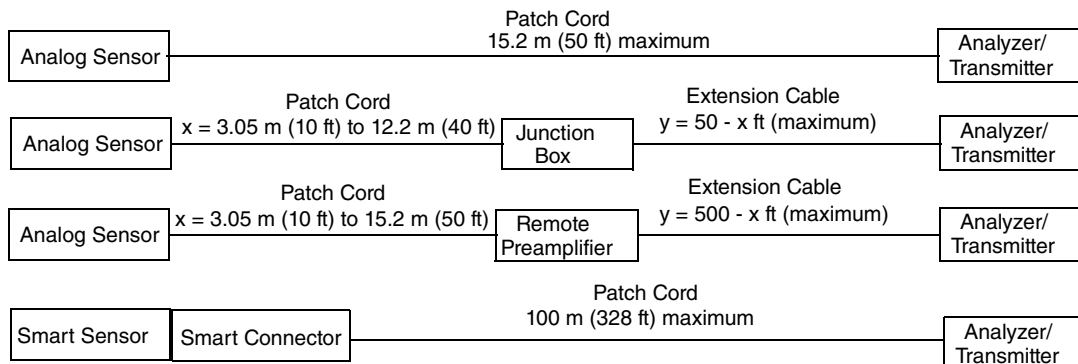

Connection to Analyzer or Transmitter

Connect the numbered wires from the patch cord or extension cable to the appropriate terminals on the transmitter, analyzer, junction box, or remote preamplifier. For sensor connections to an analyzer or transmitter, refer to Table 1. Extension cables have the same numbering and color coding as the patch cords.

Table 1. Cable Wiring for Analog Sensor

Wire Number	Cable Color	Function
1	Black	RTD
2	Brown or Dark Green	RTD
2A	Orange or White	RTD 3-Wire (see note)
3	Clear or White (Coax)	Measuring Electrode
3A	Clear (Coax Shield)	Coax Shield (screen) for Measuring Electrode
4	Green (Outer Shield)	Solution Ground
5	Red	Reference Electrode

NOTE

Wire 2A is not used with 873 Analyzers. In such applications, it must be taped back.

Table 2. Cable Wiring - Smart Sensor

Wire Number	Cable Color	Function
+	Red	Power to Sensor
-	Black	Power to Sensor

NOTE

Smart sensors may only be connected to 876PH-S version transmitters. Smart sensors cannot be used with other Foxboro transmitters, including the 876PH transmitter that is used with Analog sensors.

Variopin and Smart Connectors

Do **not** remove the patch cord from the sensor in the rain or in condensing moisture environments or otherwise allow moisture to get inside the connector. Before assembly, inspect the two parts of the connector for any sign of moisture or residue. Thoroughly remove any moisture or residue from surfaces to promote high performance.

Even though the Variopin and Smart connectors meet the ingress protection standards of IEC IP66 and IP68 for submersion at a depth of 2 m for 48 hours, it is recommended that sensors not be used in long term submersion/immersion installations.

Troubleshooting

Refer to MI 611-214.

Calibration

Calibrate your sensor and analyzer/transmitter system regularly. A sensor loses calibration for two general reasons: the slope changes or the offset changes. Slope changes are usually due to aging of the measuring electrode. Offset changes are often due to clogging and contamination of the reference junction. A single point calibration corrects the offset only. A two point calibration corrects both the offset and the slope. Frequency of calibration is dictated by the rigors of the process, such as temperature, pressure, abrasives, harsh chemicals, and so forth. It is also related to your need for accuracy. Many users do a single point, grab sample calibration frequently and a two point calibration only occasionally. Refer to your analyzer/transmitter instruction for specific calibration procedures.

Temperature Calibration

PH12 sensors include a precision temperature measuring element. Foxboro analyzers and transmitters use this temperature measurement to provide automatic temperature compensation of the pH measurements.

For optimum pH measurement accuracy, check the temperature measurement for accuracy and adjust if necessary. This is especially important when a long cable length is used with sensors that have 2-wire RTD elements. Sensors with 3-wire RTD elements automatically compensate for issues due to cable length. Refer to your analyzer/transmitter instruction for specific calibration procedures.

Smart sensors contain a 1000 Ω RTD whose signal, along with those from the measuring and reference electrodes, is converted to a digital signal in the sensor electronics.

Electrode Inspection

Fouling (the build-up of a film) on the measuring electrode and the reference junction can cause erratic output.

Inspect the electrodes as needed. Once a week is recommended for new installations. If fouling is evident, clean the electrode as described in the following sections.

Electrode Cleaning

Cleaning the Glass Electrode

First, consider the contamination you are trying to remove. In what is it soluble? What will chemically attack it? Next, consider the sensor. What cleaner will have little or no effect on the sensor itself? Choose the solvent, soap, or chemical that is the mildest but removes the contamination. Caustic is a risky choice for glass electrodes. Stronger concentrations can attack the glass. Dilute HCl (hydrochloric acid) is frequently a good choice. The concentration of HCl must be as low as possible and still remove the contamination. Consider 4% or 1 N to be a maximum.

— NOTE —

An electrode reconditioning solution is used for extreme applications. Contact the Global Customer Support for more information on when to use this solution, and how to specify it.

NOTICE
<p>POTENTIAL EQUIPMENT DAMAGE</p> <p>Avoid cleaning glass electrodes with abrasive cleaners or coarse wipers.</p> <p>Failure to follow these instructions can result in equipment damage.</p>

⚠ CAUTION
<p>RISK OF GLASS BREAKAGE</p> <p>Handle the sensor very carefully to avoid damage to the glass electrode.</p> <p>Failure to follow these instructions can result in injury or equipment damage.</p>

Rinse the electrode with distilled water. Blot the electrode and reference junction with a soft cloth.

In hard-water areas, dip the tip of the sensor in a 1 to 4% solution of HCl to remove surface film. Then rinse thoroughly.

If the electrode surface is oily, clean it with a mild detergent and fine bristle brush.

Cleaning the Reference Junction

Carefully clean the reference junction with detergent and a fine bristle brush.

Sanitizing the Sensor

The PH12 Sensor may also be sanitized via an autoclave and other steam sanitizing process.

However, before subjecting the sensor to this process, screw the autoclave cap (option -A) onto the Variopin or Smart connector end of the sensor to help to protect the electrical contacts.

Storing a Sensor

The shelf life of your sensor depends on the storage conditions. Although a shelf life is not specified, a reasonable estimate is 6 to 12 months. Under optimal conditions, sensors may last well over a year on the shelf.

When stored, keep the measuring electrode and the reference junction hydrated at normal room temperature. Store your PH12 Sensor in a 1 M (or higher) potassium chloride solution or a pH 4 or pH 7 buffer solution. Avoid storing sensors in distilled or deionized water. New sensor assemblies are shipped with the measuring and reference junction sealed in a protection container with liquid potassium chloride salt solution. Keep the container in place until you are ready to install your sensor in the process. The container can be reused to store a sensor by replenishing the solution and fitting it (in two steps) on to the sensor. First twist the container cap onto the sensor and then screw on the container bottle into the cap. This is recommended if the sensor is removed from the process for more than a few hours. Proper storage maximizes both shelf life and service life of a sensor.

ISSUE DATES

SEP 2009	FEB 2016
AUG 2010	JULY 2017
MAR 2011	
SEP 2012	

Vertical lines to the right of text or illustrations indicate areas changed at last issue date.

Schneider Electric Systems USA, Inc.
38 Neponset Avenue
Foxboro, MA 02035
United States of America
<http://www.schneider-electric.com>

Global Customer Support
Inside U.S.: 1-866-746-6477
Outside U.S.: 1-508-549-2424
<https://pasupport.schneider-electric.com>

Copyright 2009-2017 Schneider Electric Systems USA, Inc. All rights reserved.

Schneider Electric and Foxboro are trademarks of Schneider Electric Systems USA, Inc., its subsidiaries, and affiliates. All other trademarks are the property of their respective owners.

Life Is 

Foxboro[®]
by **Schneider Electric**