

Foxboro® Model 84C Flanged and Wafer Body Intelligent Vortex Flowmeters with Temperature Compensation

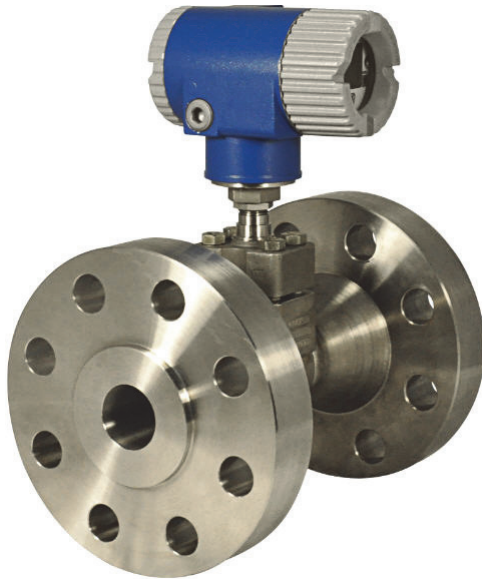

84C Flanged Body



84C Wafer Body

The Model 84C flanged and wafer vortex flowmeter is an addition to the Foxboro® family of intelligent, high performance vortex flowmeters. It is available with 4 to 20 mA, HART® 7, and pulse output. It is equipped with integral temperature compensation for flow measurement of saturated or super-heated steam and user-defined fluids. An integral LCD indicator with pushbuttons is offered for local configuration.

FEATURES

- ▶ Liquid, gas, or steam applications
- ▶ Compensation for mass flow of saturated and super-heated steam based on ASME steam tables
- ▶ Compensation for mass flow of custom fluids
- ▶ Volumetric flow rate accuracy of $\pm 0.5\%$ of reading in fluids and $\pm 1.0\%$ in gas and steam
- ▶ Mass flow rate accuracy of $\pm 1.4\%$ of reading in saturated and super-heated steam
- ▶ Process temperature accuracy of $\pm 1^\circ\text{F}$ (0.56°C) for saturated and super-heated steam
- ▶ Flanged or wafer body designs:
 - 3/4 to 12 in (DN15 to DN300) flanged body
 - 3/4 to 8 in (DN15 to DN200) wafer body
- ▶ High pressure up to Class 1500 and PN160
- ▶ *DirectSense™* technology
- ▶ Widest rangeability in class
- ▶ Low power versions available for use in battery or solar power applications
- ▶ An integrated temperature sensor for measuring process temperature

Equipment should be installed, operated, serviced, and maintained only by qualified personnel. No responsibility is assumed by Schneider Electric for any consequences arising from the use of this material.

- ▶ ActiveTuning™ algorithms:
 - ▶ Real time Reynolds number (R_D) low flow correction down to R_D of 5000
 - ▶ Compensation for piping effects
 - ▶ Adaptive filtering and signal conditioning
- ▶ Pulse output capability in raw, frequency, or pulse (total) modes
- ▶ CE marked; complies with EMC European Union and PED Directives, and NAMUR NE 21 interference immunity requirement
- ▶ CRN Registered

VORTEX SOLUTION FOR TEMPERATURE COMPENSATION OF SATURATED STEAM

The Foxboro brand 84C Vortex flowmeter provides an integrated process fluid temperature measurement. With calculations based on ASME steam tables⁽¹⁾, the Model 84C is an excellent solution for the mass flow metering of saturated steam.

VORTEX SOLUTION FOR TEMPERATURE COMPENSATION OF USER-DEFINED FLUIDS

In addition, the 84C provides algorithms for temperature compensated mass flow of any user-defined fluids. With the field-proven advantages of the rest of the Model 84 family of vortex flowmeters, including DirectSense technology and ActiveTuning, the Foxboro 84C flowmeter provides the definitive solution for temperature compensation of saturated and super-heated steam. It provides a low cost alternative to the more expensive mass flow solutions on the market.

LIVE PRESSURE INPUT VIA HART FOR SUPER-HEATED STEAM

The Foxboro brand 84C Vortex flowmeter provides a mechanism to input live pressure readings via a HART command.

These pressure readings are used in combination with the integrated process fluid temperature measurement to compensate for the super-heated steam Mass Flow calculations based on the ASME steam tables⁽¹⁾.

COMPLIANCE WITH EUROPEAN UNION DIRECTIVES

- ▶ Complies with Electromagnetic Compatibility Requirements of EMC Directive 2014/30/EU by conforming to EN 61326-1:2013.
- ▶ Complies with NAMUR NE 21 Interference Immunity Requirement (EMC).
- ▶ Complies with Pressure Equipment Directive (PED).
- ▶ Complies with applicable European Union Directives (CE Logo marked on product).

DirectSense TECHNOLOGY FOR IMPROVED PERFORMANCE AND RELIABILITY

DirectSense technology measures pressure pulses from vortex shedding directly, without losses due to mechanical linkages. Model 84C Vortex flowmeters are offered with all the advantages of *DirectSense* technology that the Model 84 Vortex flowmeter family delivers.

INTEGRATED TEMPERATURE MEASUREMENT

The Model 84C Vortex flowmeter is equipped with an integrated Class A, 1000 ohm, platinum RTD temperature sensor which allows temperature compensation for density of saturated and super-heated steam and user defined fluids. The temperature measurement is also provided as an output. The temperature sensor provides:

- ▶ Mass flow rate accuracy of $\pm 1.4\%$ for saturated and super-heated steam⁽²⁾
- ▶ Process temperature accuracy of $\pm 1^\circ\text{F}$ (0.56°C)

1. Saturated and super-heated steam based on ASME *International Steam Tables for Industrial Use* (Second Edition), 2009.

2. These specifications assume the flowmeter is insulated per MI 019-222.

SIMPLIFIED START-UP

The flowmeter can be shipped preconfigured with flow data that you provide. Otherwise, you can easily configure the flowmeter for your specific process.

ActiveTuning ALGORITHMS

Reynolds Number

The patented ActiveTuning algorithm improves accuracy down to an R_D of 5000.

Compensations for Piping Effects

When it is not possible to provide the recommended pipe diameters of unobstructed straight pipe upstream of the flowmeter, the 84C flowmeter can be configured to compensate for most of the common non-ideal upstream conditions, such as elbows and reducers. Straight runs as short as five pipe diameters can be configured to achieve full specified accuracy.

Adaptive Filtering and Signal Conditioning

A patented, adaptive filtering algorithm provides real-time, dynamic frequency filters that follow the vortex shedding frequency. This results in unsurpassed low-flow measurement capability and vibration immunity. This is incorporated with a digital smoothing algorithm that conditions the raw vortex signal to further enhance low-flow performance.

Tunable for Specific Operating Conditions

Configurable parameters for Low Flow Cut-in and damping allow tuning for specific flow conditions.

COMPACT, EFFICIENT, AND DURABLE DESIGN

The flange design of the flowmeter mates with ANSI or DIN EN 1092-1 flanges and the wafer design mounts between ANSI or DIN EN 1092-1 flanges. See "MODEL CODE-FLANGED BODY" on page 23 or "MODEL CODE-WAFER BODY" on page 27 for end connections offered with each line size. Other flange types are available on request.

The electronics housing is explosion proof and flameproof construction and provides environmental protection to the enclosed electronics. It is offered integrally mounted to the flowtube, or can be mounted remotely.

The flowmeter's simple, modular design requires minimum maintenance. Common, field replaceable parts are used, including the sensor assembly and amplifier. The amplifier can be replaced without interrupting the flow in the pipe. Since a single device is used for multiprocess-fluid applications, ordering is simplified and spare part needs are minimized.

LOW POWER OPTION

A low power option is available for use with battery power and any form of recharging technology, such as solar arrays or alternators.

USABLE IN HAZARDOUS AREA LOCATIONS

These flowmeters meet numerous agency requirements for hazardous locations.

MEASUREMENT INTEGRATION

These flowmeters provide efficient integration of measurements into HART process control schemes. They operate by using a bidirectional digital signal superimposed on the 4 to 20 mA current signal (standard power -T version) or on the fixed 10 mA supply current (low power -L version). They are also offered with a pulse output. Remote communication of digital values plus status and configuration information can be achieved via HART communication protocol.

The following can be used to configure the Model 84C Vortex flowmeter:

- ▶ A HART communicator.
- ▶ A local digital indicator/configurator with pushbuttons.
- ▶ A PC-based configurator.

With HART, digital multidropping is permitted. This is the connection of several transmitters to a single communications line. Up to 16 transmitters can be connected on a single twisted pair of wires or over leased telephone lines.

mA OUTPUT

In addition to the standard HART digital signal, Vortex flowmeters produce a milliamp output signal. For standard power 84C Vortex flowmeters, you can map a measurement to the HART primary variable (PV), and this measurement will drive the 4 to 20 mA analog output. For low power 84C Vortex flowmeters, the mA output is fixed at 10 mA.

PULSE OUTPUT

Vortex flowmeters can also produce a pulse signal in addition to the standard HART digital signal and 4 to 20 mA analog signal. Pulse output can be configured in one of the following modes.

- ▶ **Raw** mode generates a pulse frequency according to the detected raw vortex frequency after filtering.
- ▶ **Frequency** mode generates a pulse frequency proportional to a mapped measurement.
- ▶ **Pulse** mode generates one pulse output per given quantity of material flowing through the sensor.

TOTALIZERS

The 84C Vortex flowmeter provides three separate totalizers that accumulate flow measurements. To allow you to track different types of flow measurements, each totalizer can be mapped, configured, and operated independently.

REMOTE MOUNTED ELECTRONICS HOUSING

Remote mounting is offered to allow access to the amplifier and other housing electronics when the measurement is not in an easily accessible location.

The remote housing is supported by a bracket, which in turn mounts to a surface or to a nominal 2-inch or DN50 pipe. This housing can be located up to a cable length of 50 ft (15.2 m) from the flowtube without loss of low level signal.

LOCAL DIGITAL INDICATOR/CONFIGURATOR

The Model 84C flowmeter is offered with an optional multi-line local digital display, which serves as both a local configurator and measurement indicator.

The flowmeter can be easily configured in Setup mode using four pushbuttons on the front of the transmitter and an intuitive menu system.

The indicator screen, which displays real-time flowmeter measurements, is fully configurable. Depending on your application and the flowmeter's model code, you can customize the indicator to manually or automatically cycle among one or more flowmeter measurements. The indicator screen also displays rollover counters for totalizer readings, and any errors or warnings that exist.

SELF-DIAGNOSTICS

The flowmeter uses many diagnostic functions including temperature sensor continuity checks. These diagnostic functions are performed at startup and continuously in the background.

The flowmeter also has a built-in self-test function for verification of the health of the electronics module.

PATENTED TECHNOLOGY

This technology is protected by patents US 8576084 B2 and US 7853415 B2.

FlowExpertPro™ SIZING TOOL

The FlowExpertPro sizing tool is an application primarily used to size Foxboro brand flowmeters, but also helps ensure that you have selected the proper flowmeter type for your particular application. This meter selection tool is provided to all users. You can run the FlowExpertPro sizing tool from a free website or on mobile devices running the iOS operating system.

In addition to flowmeter selection and sizing, the FlowExpertPro program includes the following features:

- ▶ Incorporates a large library of the physical properties of typical process fluids.
- ▶ Displays results in tabular or graphic format.
- ▶ Allows you to save, print, or e-mail results.
- ▶ Provides reference to applicable flowmeter Product Specification Sheets (PSSs) and other related flowmeter documentation.

The program calculates minimum and maximum flow rates, rangeability, pressure loss, and Reynolds Number using established flow equations. It also allows for material and flange selection, and provides ANSI or DIN flange recommendations for predicted flow pressure and temperature. Visit www.FlowExpertPro.com to use the web-based tool, or scan the appropriate QR Code to access the web tool or mobile application. Contact Global Customer Support for further information and technical support.

Scan for access to FlowExpertPro.com



Scan for access to mobile application



OPERATING CONDITIONS FOR FLANGE AND WAFER BODY

Influence	Factory Calibration Conditions (a)	Operating Limits (b)
Process Fluid	Clear Water	Liquid, Gas, and Steam
Process Temperature <ul style="list-style-type: none"> ▶ Std. Temp. Version/Fluorolube Fill ▶ Std. Temp. Version/Silicone Fill ▶ High Temp. Version/Unfilled (c) 	<ul style="list-style-type: none"> ▶ 70° to 85°F (20° to 30°C) ▶ 70° to 85°F (20° to 30°C) ▶ 70° to 85°F (20° to 30°C) 	<ul style="list-style-type: none"> ▶ 0° and +200°F (-18° and +93°C) ▶ 0° and +400°F (-18° and +204°C) ▶ 300° and 500°F (149° and 260°C)
Ambient Temperature (Housing) <ul style="list-style-type: none"> ▶ with Indicator/Configurator ▶ without Indicator/Configurator 	<ul style="list-style-type: none"> ▶ 70° to 85°F (20° to 30°C) ▶ 70° to 85°F (20° to 30°C) 	<ul style="list-style-type: none"> ▶ 0° and +176°F (-20° and +80°C) (d) ▶ -40° and +176°F (-40° and +80°C) (d)
Relative Humidity	50 to 90%	0 and 100%
Supply Voltage	24 ±0.5 V dc	15.5 and 42 V dc (see Figure 2) 10 and 42 V dc for Low Power version (e)

- a. The factory calibration conditions assume: ANSI Schedule 160 process piping for 2-, 3-, and 4-inch line sizes using Class 1500 flanges, 6-inch (152.4 mm) and 8-inch (203.2 mm) line sizes using Class 900 and Class 1500 flanges, and DN150 and DN200 line sizes using PN160 flanges; all other line sizes and pressure options assume ANSI Schedule 40 process piping; flanges bored to interfacing pipe I.D.; piping and flowmeter body bores aligned to within 2% of meter bore; gaskets are 0.125 in (3.18 mm) thick and not protruding into pipeline; a minimum of thirty pipe diameters of straight pipe upstream and five pipe diameters downstream of flowmeter; clear water is free from air or particles.
- b. Limits are based on nonflashing, noncavitating conditions. A minimum positive back pressure is required for proper operation to avoid these effects.
- c. Sensor Options A and B for Flanged Body and E and G for Wafer Body are rated to 500°F (260°C) maximum with Multivariable selection T.
- d. The 176°F (80°C) temperature is extended to 185°F (85°C) with certain electrical approvals or certifications. Refer to Electrical Safety Specifications table.
- e. Supply current is fixed at a constant 10 mA for Electronics Version selection L and remains in operation down to a minimum terminal voltage of 10 V dc. See “Power Supply Requirements (Low Power Versions)” on page 10.

PERFORMANCE SPECIFICATIONS

Under calibrated operating conditions unless otherwise stated

Factory Calibrated Flow Ranges for Flanged and Wafer Body

Nominal Meter Size	Nominal Mean K-Factor in Pulses/ft ³ (Pulses/L) (a)	Factory-Calibrated Flow Range for Water (b)		
		Range in US gpm	Range in L/s	Range Reynolds Number (R _D)
3/4 in (DN15)	5,580 (197)	6.9 to 34	0.43 to 2.1	30,000 to 150,000
1 in (DN25)	2,250 (79.5)	8.9 to 56	0.56 to 3.5	30,000 to 190,000
1 1/2 in (DN40)	570 (20.1)	14 to 140	0.88 to 8.7	30,000 to 300,000
2 in (DN50)	258 (9.11)	18 to 230	1.1 to 15	30,000 to 380,000
2 in (DN50) Class 1500 (c)	389 (13.74)	16 to 203	1 to 12.8	30,000 to 380,000
3 in (DN80)	78.7 (2.78)	34 to 500	2.1 to 32	38,000 to 570,000
3 in (DN80) Class 1500 (c)	103 (3.64)	32 to 475	2 to 30	38,000 to 570,000
4 in (DN100)	34.8 (1.23)	59 to 890	3.7 to 56	50,000 to 750,000
4 in (DN100) Class 1500 (c)	47.29 (1.67)	55 to 818	3.4 to 51.6	50,000 to 750,000
6 in (DN150)	10.00 (0.353)	140 to 2,000	8.5 to 130	76,000 to 1,100,000
6 in (DN150) Class 900, Class 1500, PN160 (c)	13.68 (0.483)	125 to 1,812	7.9 to 114.3	76,000 to 1,100,000
8 in (DN200)	4.26 (0.150)	240 to 3,600	15 to 220	100,000 to 1,500,000
8 in (DN200) Class 900, Class 1500, PN160 (c)	5.98 (0.211)	216 to 3,244	13.6 to 204.6	100,000 to 1,500,000
10 in (DN250) (c)	2.19 (0.0773)	395 to 5,768	24.9 to 363.9	130,000 to 1,900,000
12 in (DN300) (c)	1.32 (0.0466)	578 to 8,305	36.4 to 524.0	160,000 to 2,300,000

a. The K-factor is the relationship between input (volumetric flow rate) and the output (pulse rate). Reference K-factor is the arithmetic mean value of K-factor over a designated flow rate range (reference conditions). The mean K-factor is derived as:

$$\text{Mean K-factor} = (\text{KMAX} + \text{KMIN}) / 2$$

where KMAX is the maximum K-factor and KMIN is the minimum K-factor over the calibrated flow range.

b. Factory calibrated Reynolds Number range applies to standard temperature sensors. Other sensor selections may alter the calibration range. For sizing tools and specific calibration ranges, visit www.FlowExpertPro.com.

c. This size is only available with the 84C Flanged Body. Not available for 84C Wafer Body.

REFERENCE ACCURACY

Volumetric Flow for Fluids

Accuracy within the calibrated range is as follows (also see Figure 1):

- ▶ Greater than 30,000 R_D ; $\pm 0.5\%$
- ▶ Between 20,000 and 30,000 R_D ; $\pm 1.0\%$
- ▶ Between 5,000 and 20,000 R_D ; $\pm 2.0\%$

Figure 1. Flowmeter Accuracy for Fluids

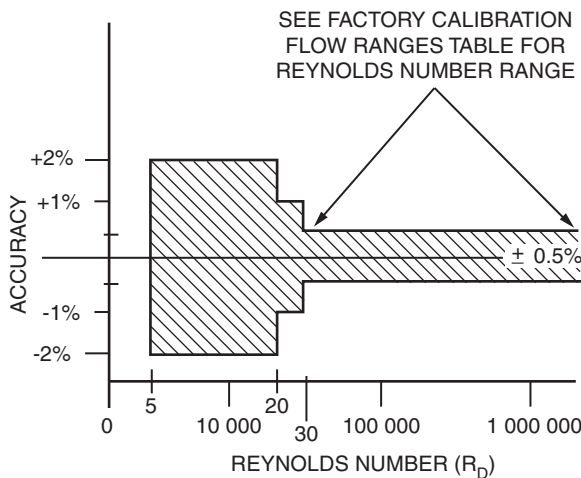

Volumetric Flow for Gases and Steam

Accuracy within the calibrated range is as follows:

- ▶ Greater than 20,000 R_D ; $\pm 1.0\%$
- ▶ Between 5,000 and 20,000 R_D ; $\pm 2.0\%$

NOTE

To achieve these fluid accuracies for gases and steam, you must configure the flowing density and viscosity. To determine accuracy for specific applications and use other sizing tools, visit www.FlowExpertPro.com.

Mass Flow for Saturated and Super-Heated Steam⁽³⁾

For Reynolds Number Greater Than 20,000

Mass flow accuracy for velocities greater than 10 m/s (33 ft/s) and temperature greater than 143°C (290°F):

- ▶ $\pm 1.4\%$ of rate

Mass flow accuracy for velocities 5 to 10 m/s (16.4 ft/s to 33 ft/s) and temperature greater than 143°C (290°F):

- ▶ $\pm 1.9\%$ of rate

For Reynolds Number Between 5,000 and 20,000

Mass flow accuracy for velocities greater than 10 m/s (33 ft/s) and temperature greater than 143°C (290°F):

- ▶ $\pm 2.2\%$ of rate

Mass flow accuracy for velocities 5 to 10 m/s (16.4 ft/s to 33 ft/s) and temperature greater than 143°C (290°F):

- ▶ $\pm 2.57\%$ of rate

For Temperatures Less Than 143°C (290°F)

- ▶ Add an uncertainty of $\pm 0.1\%$ for every 5.6°C (10°F) less than 143°C (290°F)

Process Temperature for Saturated and Super-Heated Steam⁽³⁾

Process temperature accuracy for velocities greater than 10 m/s (33 ft/s) and for temperatures greater than 149°C (300°F):

- ▶ $\pm 0.56^\circ\text{C}$ ($\pm 1^\circ\text{F}$)

3. These specifications assume the flowmeter is insulated per MI 019-222.

EXTERNAL INFLUENCES

Supply Voltage (Within Stated Limits)

- ▶ With Pulse Output: No effect on accuracy
- ▶ With Analog Output: Less than 0.005% per volt
- ▶ With Digital Output: No effect on accuracy

Ambient Temperature (Amplifier only)

- ▶ With Pulse Output: ±0.01% of reading from -40° to +176°F (-40° to +80°C)⁽⁴⁾
- ▶ With Analog Output: For 50°F (28°C) change in ambient temperature within operative limits.
 - Zero (4 mA): ±0.02% of span maximum
 - Span (16 mA): ±0.1% of span maximum
- ▶ With Digital Output: ±0.01% of reading from -40° to +176°F (-40° to +80°C)⁽⁴⁾

Relative Humidity

No effect if covers and conduit seals are properly installed.

EMI and RFI

The flowmeters meet the EMI and RFI requirements of EN 61326-1.

Vibration

The flowmeter complies with IEC 60068-2-6 for 10 to 500 Hz up to 2 “g”.

Switching and Indirect Lightning Transients

The transmitter can withstand a transient surge up to 2000 V common mode or 1000 V normal mode without permanent damage. Transmitter complies with ANSI/IEEE C62.41-1980 and IEC 61000-4-5.

Complies with Electromagnetic Compatibility requirements of European EMC Directive 2004/108/EC by conforming to EN 61326-1 and IEC 61000-4-2 through 61000-4-6.

RFI

Complies with IEC 61000-4-3.

FUNCTIONAL SPECIFICATIONS

Remote Digital Communication

Remote digital communications are carried out via a HART Communicator or PC-based configurator at a communication rate of 1200 baud, and a rated communication distance of 6000 ft (1800 m). Remote digital communication can also be carried out through a control system.

Local Communication/Configuration

In addition to remote communications, a local digital indicator/configurator with pushbuttons is also available for local interrogation and configuration.

Communication Format

- ▶ Analog 4 to 20 mA with HART superimposed
- ▶ HART communications with fixed mA output

Table 1. Remote Communication Parameters

Parameter	HART Analog or Digital Multidrop Mode
Remote Configurator/Communicator	HART Communicator or PC-Based Configurator
Communication Rate	1200 baud
Communication Distance (Rated)	6000 ft (1800 m)
Measurement Update	5 times/s
Raw Pulse Measurement Update	Vortex Shedding Frequency

4. The 176°F (80°C) temperature may be extended to 185°F (85°C). Refer to “ELECTRICAL SAFETY SPECIFICATIONS” on page 18.

Write Protect Jumper

A write protect jumper provides additional defense by allowing or preventing the local or remote configurators from writing to the electronics. This write protection capability meets the security requirements of ISA-584.01-1986.

NOTE

Without the jumper installed, the Vortex flowmeter electronics module is write protected.

Password Protection

Password protection is provided in the local display/configurator mode to help ensure operating integrity. A second level of protection is provided for configuration integrity.

On-Line Diagnostics

The flowmeter uses many internal diagnostic functions including hardware checks and internal code and database validation. The 4 to 20 mA output follows the NAMUR 43 standard where:

- ▶ Fail Low is ≤ 3.6 mA
- ▶ Under Range is < 3.8 mA
- ▶ Over Range is > 20.5 mA
- ▶ Fail High is ≥ 21.0 mA

The 4 to 20 mA output can be configured to fail high or fail low.

Self-Test

The transmitter initiates self-tests to verify the health of the transmitter electronics. This test uses an internally generated frequency signal.

Temperature Sensor Diagnostics

Software running in the Vortex flowmeter provides temperature sensor continuity checks.

Power Supply Requirements (Standard Power Versions)

Supply Current

- ▶ Digital Mode: 10 mA dc nominal
- ▶ Analog Mode: 22 mA dc maximum
- ▶ Pulse Output: 20 mA dc maximum

Supply Voltage

- ▶ 15.5 to 42 V dc, depending on electrical safety approvals and certifications. Refer to Figure 2.

NOTE

When operating at ambient temperatures less than -20°F (-29°C), it is important to maintain a minimum loop voltage of 15.75 V dc to maintain remote configurator communications capability.

Figure 2. Supply Voltage vs Output Load for 4 to 20 mA Output

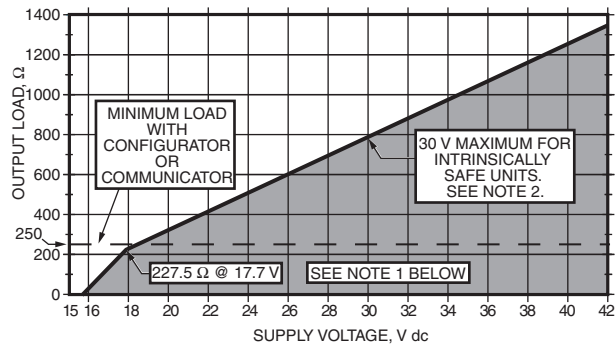

NOTE

1. The transmitter will function with an output load less than 250 Ω provided that a PC-based configurator or HART communicator is not connected to it. Connecting a PC-based configurator or HART communicator while operating in this area may cause output and/or communication disturbances.
2. With intrinsically safe certifications with a 24 V dc supply, an active barrier is required.

Power Supply Requirements (Low Power Versions)

Supply Current

- ▶ 10 mA dc nominal

Supply Voltage Limits

- ▶ 10 and 42 V dc

NOTE

For proper operation, 10 V dc must be maintained at the flowmeter terminals. For HART communications, a 250 Ω load resistor must be included in the power supply loop and a supply voltage of 12.5 V dc must be maintained. See installation MI for typical installation topologies.

Output Damping

Damping smooths the flow rate output, and optimizes the flowmeter's response time to the control system. Damping is an exponential filter, 85% recovery time to an input step that is 80% of span, with a selectable time constant; it can be set between 0 and 32 seconds. An eight second damping factor will pass 85% of the step change in this time period. Damping applies to all outputs except the Raw Pulse Output where no damping is applied to the direct vortex shedding frequency.

Response Time (Without Damping)

Analog Mode

0.5 second or the vortex shedding period for frequencies less than 2 Hz.

Digital Mode

0.5 second or the vortex shedding period for frequencies less than 2 Hz.

Pulse Output

- ▶ Raw mode: Vortex shedding frequency
- ▶ Frequency or Pulse mode: 0.25 s or the vortex shedding period for frequencies less than 2 Hz.

Outputs

These flowmeters support the following outputs:

- ▶ HART Version -T: Digital and 4 to 20 mA output, with a pulse output
- ▶ HART Version -L: Digital output with a pulse output

Analog Output

Flow rate available as a 4 to 20 mA signal with the 20 mA value being set by the configured full range flow rate.

Digital Output

Digital information is superimposed on a 4 to 20 mA signal (standard power versions) or the power supply loop (low power versions) at 1200 baud (see Table 1). For low power versions, output is fixed at 10 mA.

Pulse Output

The pulse output can be configured with the full-function electronics in one of the following modes:

- ▶ Raw Mode: The vortex shedding frequency is directly passed through, providing an instantaneous, nondampened frequency output.
- ▶ Frequency mode: The frequency of this output is a 50% duty cycle pulse output with a frequency range of 0 to 10,000 Hz, proportional to zero flow to the full range flow rate/upper range value (URV).
- ▶ Pulse mode: The frequency of this output is also a 50% duty cycle pulse output that is configured to provide a pulse when a determined volumetric/totalized unit has flowed through the meter.

Pulse Output Specifications

The pulse output is an externally powered 2-wire transistor switch type output. This output can be configured using any applicable configuration device to select one of three pulse output modes: raw, frequency, and pulse. The following specifications apply to all three types of pulse output modes:

- ▶ Isolated 2-Wire Transistor Switch
- ▶ Applied Voltage: 5 to 30 V dc
- ▶ Maximum “ON” State Voltage Drop: 1.0 V dc
- ▶ Maximum “ON” State Current: 20 mA
- ▶ Reverse polarity protected
- ▶ Short circuit protected
- ▶ Connectable to pulse counters

Output Combinations (4 to 20 mA Outputs)

Flowmeter wired as a 2-wire device without pulse output, and as a 4-wire device with pulse output.

Flowmeter Ranges

Flowmeter is shipped with the flow range specified in the sales order or with a default flow range equal to the meter capacity. You can rerange the flowmeter and keep the same flow rate units, choose new flow rate units from a built-in menu-selectable list, or enter custom flow rate units. Table 2 is included for reference only.

To determine flow velocity limits and use other sizing tools, see “FlowExpertPro™ SIZING TOOL” on page 5 or visit www.FlowExpertPro.com.

Nominal Flow Velocity Limits

These limits can be calculated using Table 2. In the table, ρ_f is the fluid density at flowing conditions in kg/m^3 for metric (SI) units, or in lb/ft^3 for U.S. customary units. The specifications apply for most applications, but can deviate slightly for some combinations of density and line size.

Table 2. Nominal Flow Velocity Limits

Range Limit	Standard Temperature Range		Extended Temperature Range	
	m/s	ft/s	m/s	m/s
Lower (a)	$3.0/\sqrt{\rho_f}$	$2.5/\sqrt{\rho_f}$	$6.0/\sqrt{\rho_f}$	$5.0/\sqrt{\rho_f}$
Upper	$300/\sqrt{\rho_f}$	$250/\sqrt{\rho_f}$	$300/\sqrt{\rho_f}$	$250/\sqrt{\rho_f}$

a. Values given for lower range velocity limit are at the lowest LFCI setting.

Reference K-Factor

The reference K-factor is a coefficient that specifies the flowmeter calibration and is expressed as pulses per unit volume, where $\text{pulses/unit volume} = \text{pulses per second divided by volume flow per second}$.

The reference K-factor is the arithmetic mean value of K over the factory-calibrated flow range. It is determined at the factory by actual flow calibration with water by comparison to a master flowmeter calibration, or by actual static weight. Both calibrations are traceable to NIST. The reference K-factor is entered in the flowmeter database and stamped on the data plate. Once established, this K-factor is available to gas, liquid, or steam.

Flowing K-Factor

The flowing K-factor is computed from the K-reference expressed in specified flowing units, and can be corrected for the following:

- ▶ Process Temperature
- ▶ Mating Pipe
- ▶ Upstream Disturbances

Process Temperature Effect on K-Factor

There is an effect on the reference K-factor due to a diameter change of the flowtube bore with temperature. The effect is -0.3% of flow rate per 100°F (55°C) increase in temperature. These flowmeters automatically recompute a flowing K-factor based on detected changes in process temperature.

K-Factor Bias

Provisions are made in the configuration menu to bias the flowmeter K-factor by a percent (%) value. Flowing K-factor value is automatically recalculated when the % bias is entered.

Static Pressure Limits

Minimum Static Pressure

The minimum static pressure is that pressure which is sufficient to prevent flashing and meet the pressure drop requirements to attain maximum flow rate. For sizing tools, visit www.FlowExpertPro.com.

Maximum Static Pressure

Flanged Body

3750 psig (258.6 bar) (25855 kPa) or that imposed by flange rating.

Wafer Body

1500 psig (103.4 bar) (10340 kPa) or that imposed by flange rating. Reference temperature 100°F.

To determine the pressure drop for Model 84C Vortex flowmeters and use other sizing tools, visit www.FlowExpertPro.com.

Minimum Back Pressure (Volatile Liquids or Low Pressure Conditions)

Any condition that tends to contribute to the release of vapor from the liquid (flashing, which may also induce cavitation) shall be avoided by proper system design and operation of the flowmeter within the rated flow rate range. Location of the flowmeter should consider the need for using a back-pressure valve, or for increasing inlet pressure. To avoid flashing and to ensure stable vortex generation, the minimum back pressure should be:

$$P_G = (3)(\Delta P) + (1.25)(p_v) - (p_{atm})$$

where

P_G = Gauge pressure in kPa or psi five pipe diameters downstream of the flowmeter

ΔP = Pressure loss in psi or kPa

p_v = Vapor pressure at line conditions in psi or kPa absolute

p_{atm} = Atmospheric pressure in psi or kPa absolute

Flange Pressure-Temperature Ratings

See MI 019-222 for ANSI and DIN flange pressure-temperature ratings. These ratings are also embedded in the FlowExpertPro sizing tool. Also observe the temperature limit when fluorolube fill (200°F/90°C) or silicone fill (400°F/200°C) is used, or when the unfilled extended temperature sensor with temperature compensation (500°F/260°C) is used with extended temperature applications.

Functional Block Diagrams

Figure 3. HART 4 to 20 mA Topology

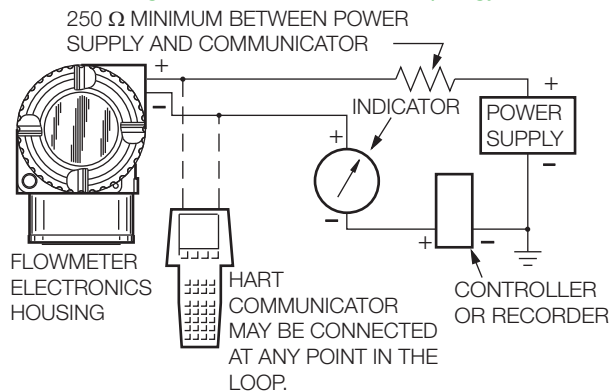
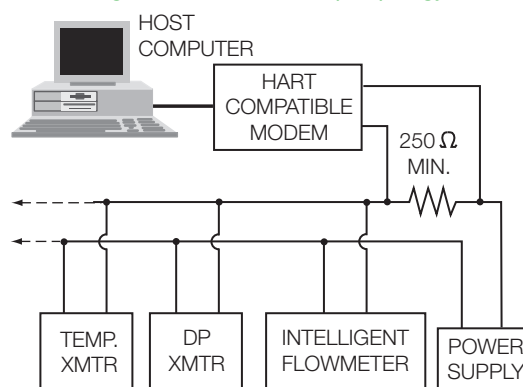

Figure 4. HART Multidrop Topology



PHYSICAL SPECIFICATIONS

Process-Wetted Parts

Table 3. 84C Flanged Body - Flowmeter Body, Shedder Bar, and Flanges

Line Sizes	Body/Shedder Bar	Flange
3/4 to 4 inch (15 to 100 mm) (Codes 008 to 040)	Cast 316 ss, CF8M	316 ss
6 to 8 inch (150 to 200 mm) (Codes 060 to 080)	Cast 316 ss, CF8M	304 ss
10 and 12 inch (250 and 300 mm) (Codes 100 and 120)	Fabricated 304 ss per ASTM 312	304 ss

Table 4. 84C Wafer Body - Flowmeter Body, Shedder Bar, and Flanges

Line Sizes	Body/Shedder Bar
3/4 to 8 inch	Cast 316 ss, CF8M
3/4 to 4 inch	Nickel alloy CW2M (a)

a. Equivalent to Hastelloy® C-4C.

Table 5. 84C Flanged and Wafer Body - Gaskets and Flow Dam (Sensor Seals)

Sensor Type	Gasket Material	Flow Dam Material
Standard Temperature Sensor	PTFE	PTFE
High Temperature Sensor	316 ss	316 ss/grafoil
	Nickel alloy CW2M (a)	Nickel alloy CW2M/grafoil (a)

a. Equivalent to Hastelloy® C-4C.

Flowmeter Mounting

Flowmeter can be located in a pipeline which may run in any direction from the vertical (upward flow) to the horizontal. The electronics housing can also be rotated 270° (in 90° increments) with respect to the body. A vertical pipeline is preferred for batch operations to provide improved full line assurance. See "RECOMMENDED MOUNTING ARRANGEMENTS" on page 20.

Electrical Connections

Field wires enter through 1/2 NPT or M20 conduit threaded entrances on either side of the electronics housing. Wires terminate under screw terminals and washers on terminal block (see Figure 5) in the field terminal compartment. Unused entrance is plugged to help protect from moisture and RFI/EMI.

Electronics Housing and Housing Covers

A two compartment housing separates the electronics from the field connections. Housing and covers are low copper (0.6% maximum) die-cast aluminum alloy with an epoxy finish. Buna-N O-ring seals are used to seal the housing covers, housing neck, and terminal block.

Figure 5. Terminal Block

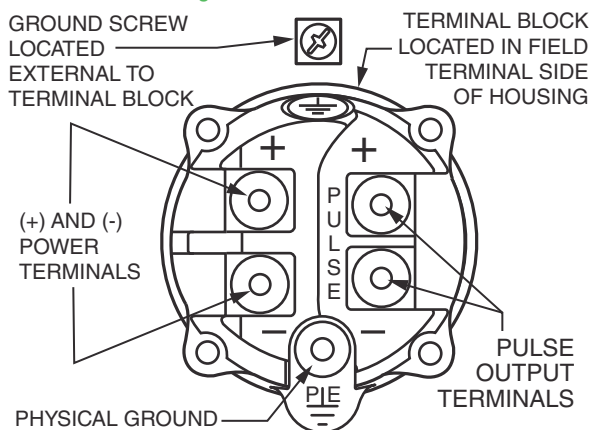

Electronics Module

Printed wiring assemblies (PWAs) are conformally coated for moisture and dust protection.

Environmental Protection

The electronics housing has the dust tight and weatherproof rating of IP66 as defined by IEC 60529, and provides the environmental and corrosion resistant protection rating of NEMA 4X.

Data Plate

Stainless steel data plate encircles and is fastened to the lower part of the electronics housing. It includes conventional Model and operating data, such as the factory calibration factor (K-factor). If additional tag data space is required, an optional Stainless Steel Customer Tag is offered.

NACE Certification

The Model 84C flowmeters have been designed to meet the requirements of NACE Standard MR-0175-2003 for use in H₂S Sour Oilfield environments. The design and process wetted materials also comply with NACE Standard MR-0103-2007 for use in corrosive petroleum refining environments. A NACE compliance certificate is available by selecting the -Q option.

Dimensions

Refer to "DIMENSIONS – NOMINAL (FLANGED BODY)" on page 30 for general outline data. For more dimensional details, refer to DP 019-127.

Approximate Weight

Refer to Table 6 for Flanged Body and Table 7 for Wafer Body. Weights shown are approximate and are meant as a guide.

Standard temperature flowmeter weights are listed for integrally mounted electronics housings. There is a slight weight difference for high temperature flowmeters (adds about 1 lb (0.5 kg)), and for remote mounted housings (housing replaced by connector head assembly/junction box). The electronics housing itself weighs about 4 lbs (2 kg) and varies slightly depending on whether indicator/configurator, and/or extended housing covers are used.

Table 6. Model 84C Flanged Body Approximate Weight

Nominal Line Size	Flanged Body		
	Type	Material	Weight, lb (kg)
0.75 in	Class 150	316 ss	10.4 (4.71)
0.75 in	Class 1500	316 ss	19.3 (8.75)
1 in	Class 150	316 ss	12.2 (5.53)
1 in	Class 1500	316 ss	24.3 (11.02)
1.5 in	Class 150	316 ss	16.7 (7.57)
1.5 in	Class 1500	316 ss	34.5 (15.65)
2 in	Class 150	316 ss	20.9 (9.48)
2 in	Class 1500	316 ss	54.2 (24.58)
3 in	Class 150	316 ss	43.0 (19.50)
3 in	Class 1500	316 ss	109.7 (49.76)
4 in	Class 150	316 ss	46.4 (21.05)
4 in	Class 1500	316 ss	155.9 (70.72)
6 in	Class 150	316 ss	77.6 (35.2)
6 in	Class 600	316 ss	178.1 (77.92)
6 in	Class 1500	316 ss	357.0 (161.93)
8 in	Class 150	316 ss	127.3 (57.74)
8 in	Class 600	316 ss	289.4 (131.26)
8 in	Class 1500	316 ss	657.2 (298.1)
10 in	Class 150	304 ss	160.0 (72.57)
10 in	Class 600	304 ss	476.2 (216.0)
12 in	Class 150	304 ss	252.4 (114.48)
12 in	Class 600	304 ss	540.4 (245.12)
DN15	PN40	316 ss	12.3 (5.58)
DN15	PN100	316 ss	16.2 (7.35)
DN25	PN40	316 ss	13.4 (6.08)
DN25	PN160	316 ss	19.1 (8.66)
DN40	PN40	316 ss	17.9 (8.12)
DN40	PN160	316 ss	28.2 (12.79)
DN50	PN40	316 ss	21.7 (9.84)
DN50	PN160	316 ss	38.4 (17.42)
DN80	PN40	316 ss	33.3 (15.10)
DN80	PN160	316 ss	58.6 (26.58)
DN100	PN40	316 ss	44.4 (20.14)
DN100	PN160	316 ss	81.2 (36.83)
DN150	PN16	316 ss	61.5 (27.89)
DN150	PN160	316 ss	195.8 (88.81)
DN200	PN16	316 ss	94.8 (43)
DN200	PN160	316 ss	356.7 (161.79)

Table 6. Model 84C Flanged Body Approximate Weight (Continued)

Nominal Line Size	Flanged Body		
	Type	Material	Weight, lb (kg)
DN250	PN16	304 ss	143.6 (65.13)
DN250	PN100	304 ss	421.6 (191.23)
DN300	PN16	304 ss	204.4 (92.71)
DN300	PN100	304 ss	618.0 (280.32)

Table 7. Model 84C Wafer Body Approximate Weight for 316 ss

Nominal Line Size		Wafer Body	
in	mm	lb	kg
3/4	DN 15	5	2.3
1	DN 25	6	2.7
1 1/2	DN 40	7	3.2
2	DN 50	10	4.5
3	DN 80	18	8.0
4	DN 100	25	11.5
6	DN 150	35	16
8	DN 200	60	27

Table 8. Body Internal Dimensions — Body Style F — Flanged and W-Wafer for Schedule 80 Bore (a)

ANSI/DIN Nominal Line Size		Bore (ID)	
in	mm	in	mm
0.75	15	0.74	18.8
1.00	25	0.96	24.3
1.50	40	1.50	38.1
2.00	50	1.94	49.2
3.00	80	2.87	72.9
4.00	100	3.83	97.2
6.00	150	5.76	146.3
8.00	200	7.63	193.8
10.00 (b)	250	9.56	242.9
12.00 (b)	300	11.38	289.0

- a. Dimensions are for following flange offerings:
 - 3/4"-1.5": ANSI Class 150-1500
 - DN15-DN40: PN40-PN160
 - 2"-4": ANSI Class 150-900
 - DN50-DN100: PN40-PN160
 - 6"-12": ANSI Class 150-600
 - DN150-300: PN16-PN100
- b. Applies to Body Style F- Flanged only.

Table 9. Body Internal Dimensions — Body Style F — Flanged for Schedule 160 Bore (a)

ANSI/DIN Nominal Line Size		Bore (ID)	
in	mm	in	mm
2.00	50	1.69	42.8
3.00	80	2.63	66.7
4.00	100	3.44	87.3
6.00	150	5.19	131.8
8.00	200	6.81	173.1

- a. Dimensions are for following flange offerings:
 - 2"-4": ANSI Class 1500
 - 6"-8": ANSI Class 900-1500
 - DN150-200: PN160

PRODUCT SPECIFICATIONS

Pressure Tolerance

Designed to withstand pressure within ANSI/ASME B16.5 Class 150, 300, 600, 900, or 1500 flange ratings, and DIN EN 1092-1, PN16, PN25, PN40, PN63, PN100, or PN160 flange ratings. See MI 019-222 for ANSI and DIN flange pressure-temperature ratings. For other flange ratings, centering spacers are provided.

NOTE

For 84C Wafer Body Flowmeters, the flowtube face outside diameter is designed to center between ANSI Class 150 flanges. For other flange ratings, centering spacers can be specified from the Mounting and Centering System selection in the Model Code.

Electrical Fire Precautions

This device is designed to be a minimum fire hazard by using low energy power and adequate insulation and separation of electrical circuits. The required standards of worldwide testing agencies such as ATEX, CSA, EAC, FM, IECEx, INMETRO, and OSHA have been fulfilled.

ELECTRICAL SAFETY SPECIFICATIONS

The Model 84C has been designed to meet the electrical safety descriptions listed in Table 10. For detailed information, or status of the testing laboratory approval/certification, contact Global Customer Service.

With intrinsically safe approvals and certifications with a 24 V dc supply, an active barrier is required.

Refer to MI 019-177 for FM and CSA Connection Diagrams; refer to MI 019-179 for ATEX and IECEx Safety Information.

Table 10. Electrical Safety Specifications

Testing Laboratory, Type of Protection, and Area Classification (a) (b)	Application Conditions	Elect. Safety Code
ATEX Specifications		
ATEX Intrinsically safe: II 1GD; II 2D; Ex ia IIC T4 Ga Ex tb IIIC T103°C Db	Sira 06ATEX2067X Integrally mounted or remote mounted (electronics and junction box). Temperature Class T4; Ta = -40° to +80°C	AA
ATEX Flameproof: II 2/1 (1) GD; II 2D Ex db [ia Ga] ia IIC T4 Gb Ex tb IIIC T85°C Db	Sira 06ATEX2067X Integrally mounted electronics. Temperature Class T4; Ta = -20° to +80°C	AD
ATEX Flameproof: II 2 (1) GD; II 2D Ex db [ia Ga] IIC T4 Gb Ex tb IIIC T85°C Db	Sira 06ATEX2067X Electronics housing of remote mounted version. Temperature Class T4; Ta = -20° to +80°C	
INMETRO Specifications		
INMETRO Intrinsically safe: Ex ia IIC T4 Ga; Ex tb IIIC T103°C Db	IS Integral or Remote Mount Temperature Class: -40°C ≤ Ta ≤ +80°C	BA
INMETRO Flameproof: Ex db [ia Ga] ia IIC T4 Gb; Ex tb IIIC T85°C Db	Explosion proof Integral Temperature Class: -20°C ≤ Ta ≤ +80°C	BD
INMETRO Flameproof: Ex db [ia Ga] IIC T4 Gb; Ex tb IIIC T85°C Db	Explosion proof Remote Temperature Class: -20°C ≤ Ta ≤ +80°C	
CSA Specifications (c)		
CSA Intrinsically safe for Class I, II, III, Div. 1, Groups A, B, C, D, E, F, and G. Also Zone certified intrinsically Ex ia IIC	Temperature Class T4; Ta = -40° to +80°C	CA
CSA explosionproof with IS sensor connection for Class I, Div. 1, Groups B, C, and D; dust-ignitionproof for Class II, Div. 1, Groups E, F, and G; Class III Div. 1, Groups E, F, and G; Class III Div. 1, Also Zone certified Ex d [ia] IIC.	Temperature Class T5; Ta = 60°C Temperature Class T5; Ta = -40° to +80°C	CD
CSA Class I, Div. 2, Groups A, B, C, and D; Class II, Div. 2, Groups F and G; Class III, Div. 2	Temperature Class T4; Ta = 80°C	CN
IECEx Specifications		
IECEx intrinsically safe: Ex ia IIC T4 Ga; Ex tb IIIC T103°C Db	Temperature Class T4; Ta = -40° to +80°C	EA
IECEx flameproof: Ex db [ia Ga] ia IIC T4 Gb Ex tb IIIC T85°C Db	Integrally mounted electronics. Temperature Class T4; Ta = -20° to +80°C	ED
IECEx flameproof: Ex db [ia Ga] IIC T4 Gb Ex tb IIIC T85°C Db	Electronics housing of remote mounted version. Temperature Class T4; Ta = -20° to +80°C	

Table 10. Electrical Safety Specifications (Continued)

Testing Laboratory, Type of Protection, and Area Classification (a) (b)	Application Conditions	Elect. Safety Code
FM Specifications		
FM Intrinsically safe for Class I, II, III, Div. 1, Groups A, B, C, D, E, F, G; Also Zone approved AEx ia IIC	Temperature Class T4; Ta = 80°C	FA
FM explosionproof with IS sensor connection for Class I, Div. 1, Groups B, C, and D; dust-ignitionproof for Class II, Div. 1, Groups E, F, and G; Class III, Div. 1.	Temperature Class T5; Ta = 85°C	FD
FM nonincendive for Class I, Div. 2, Groups A, B, C, and D; Class II, Div. 2, Groups F and G Class III, Div. 2	Temperature Class T4; Ta = 80°C	FN
EAC Specifications		
EAC Intrinsically safe: 0Ex ia IIC T4 Ga X; Ex tb IIIC T103°C Db X	IS Integral or Remote Mount Temperature Class: -40°C ≤ Ta ≤ +80°C	RA
EAC Flameproof: 1Ex d [ia Ga] ia IIC T4 Gb X; Ex tb IIIC T85°C Db X	Explosion proof Integral Temperature Class: -20°C ≤ Ta ≤ +80°C	RD
EAC Flameproof: 1Ex d [ia Ga] IIC T4 Gb X; Ex tb IIIC T85°C Db X	Explosion proof Remote Temperature Class: -20°C ≤ Ta ≤ +80°C	
CE Specifications		
Unit with CE mark and PED controls and records		YY
Unit does not have CE mark; not to be installed in European Union (EU) countries		ZZ

- With intrinsically safe approvals and certifications with a 24 V dc supply, an active barrier is required.
- When the LCD indicator is used, the low temperature limit is -20°C.
- Refer to MI 019-177 for FM and CSA Connection Diagrams.

RECOMMENDED MOUNTING ARRANGEMENTS

Table 11. Recommended Flowmeter Mounting

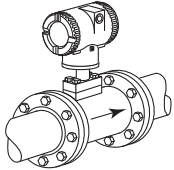
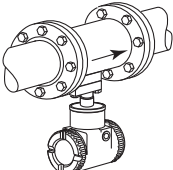
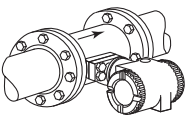
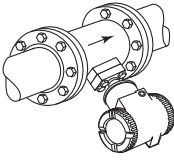
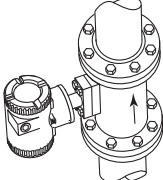
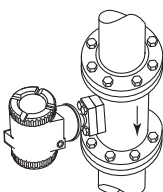
Flowmeter Mounting Arrangements		Flowmeter for Use With:			
		Liquid	Gas	Saturated Steam	Superheated Steam
	Housing Above Pipe	Yes (a)	Yes	No	Yes (b)
	Housing Below Pipe	Yes (c) (d)	Yes (d)	Yes (b)	Yes (b)
	Housing to Side of Pipe	Yes	Yes	No	Yes (b)
	Housing to Side and Below Pipe	Yes	Yes	No	Yes (b)
	Vertical Pipe, Flow upward	Yes	Yes	No	Yes (b)
	Vertical Pipe, Flow Downward	Yes (e)	Yes	No	Yes (b)

- a. Possibility of temporary start-up error due to trapped air.
- b. Requires adequate insulation. See MI 019-222.
- c. Best choice when errors due to start-up cannot be tolerated.
- d. Recommended only for clean fluids.
- e. Not preferred; must maintain full pipe with no voids in fluid.

OPTIONAL SELECTIONS AND ACCESSORIES

Options -B, -D, -E, -G: Cable Assembly to Remote Electronics Housing

When selecting Code -R for a Remote Mounted Housing, you must also select a cable length. Four cable lengths are offered:

Option	Cable Length
-B	20 ft (6 m)
-D	30 ft (9 m)
-E	40 ft (12 m)
-G	50 ft (15 m)

Option -H: Cleaning for Oxygen or Chlorine Gas Service

Process wetted parts are cleaned for oxygen or chlorine service in compliance with Compressed Gas Association's CGA-4.1 and ASTM G93. Select Option -H.

Option -A: Tamperproof and Custody Transfer

This option is recommended if you need tamperproof sealing for housing and covers. Select Option -A.

Option -J: Gold Plated Sensor

This option is recommended for H₂ (Hydrogen) processes. Select Option -J.

Options -L, -M, -Q: Foxboro Certificates of Conformance and Compliance

Three material certificates are offered. Option -L provides a certificate of compliance to the specifications of the Foxboro Quality System, which conforms to ISO 9001. Option -M is a certification of material for process wetted metal (conforms to EN 10204 Type 3.1 certificate). Option -Q certifies that process-wetted materials meet NACE Standards MR-0175-2003 and MR-0103-2007.

Option -N: Certified Calibration Certificate

A calibration and pressure test sheet come standard with each flowmeter. A certified flow calibrated K-factor and pressure test certificate is available by selecting Option -N.

Options -F, -X: Welding Certificates – With Flanged Body Flowtubes Only

Two certificates are available. Option -F certifies that the fabrication of flowtubes by welders is to ASME Boiler Code, Section IX. Option -X certifies that welding is per ASME Boiler Code, Section IX and Radiographic Examination.

Option -P: Cable Connector - Hawke-Type Cable Gland

A brass cable gland with 1/2 NPT external thread provides support for field cable. Ensure that this cable connector is qualified to meet the electrical safety specification selected. See "ELECTRICAL SAFETY SPECIFICATIONS" on page 18. Available with Electronics Housing Codes T and R only (1/2 NPT). Select Option -P.

Option -R: Cable Connector - PG11 Cable Gland

A PG11 cable gland with 1/2 NPT external thread provides strain relieved support for field cable. The PG11 is for cable diameters from 0.31 to 0.47 inches (8 to 12 mm). Ensure that this cable connector is qualified to meet the electrical safety specification selected. See "ELECTRICAL SAFETY SPECIFICATIONS" on page 18. Available with Electronics Housing Codes T and R only (1/2 NPT). Select Option -R.

Option -T: Conduit Fitting

A conduit fitting is available with Remote Mounting Code R only. It is provided when conduit is used to enclose the cable between the flowtube body and remote transmitter. Both ends of the fitting are 1/2 NPT and interconnect the conduit and transmitter at the housing and flowtube ends. Specify Option -T.

AS Code MTS: Stainless Steel Customer Tag Accessory

A 1.5 x 3.5 in (40 x 90 mm) stainless steel tag for customer data that does not fit on the standard plate. It is fastened to housing with wire. Accommodates 10 lines of data with 40 characters/spaces per line. Tag will also show customer's K-factor (information with flowing conditions being submitted with sales order). Specify AS Code MTS.

Bolting Kits – With Wafer Body Flowtubes Only

Sets of carbon steel studs and nuts which conform to line size, and ANSI or DIN size and rating, are offered in 3/4 to 4 in line sizes for ANSI flanges, and DN 50 to DN 100 mm line sizes for DIN flanges. Refer to Tables 12 and 13 to select the kit and part number required.

Table 12. ANSI Flange Bolting Kit Part Numbers

Size	Cl. 150	Cl. 300	Cl. 600
3/4 in	D0148ZF	D0148ZJ	D0148ZJ
1 in	D0148ZF	D0148ZJ	D0148ZJ
1 1/2 in	D0148ZF	D0148ZK	D0148ZS
2 in	A2044HB	A2044HB (a)	A2044HC (a)
3 in	A2044HC	A2044HD	A2044HD
4 in	A2044HC (a)	A2044HD	A2044HE

a. Two kits required.

Table 13. Metric Flange Bolting Kit Part Numbers

Size	PN 16	PN 40	PN 64	PN 100
DN 50	N/A	D0148ZU	N/A	N/A
DN 80	N/A	D0148ZZ (a)	N/A	N/A
DN 100	L0114NT	L0114NT	N/A	N/A

a. Two kits required.

MODEL CODE-FLANGED BODY

Description	Model
Vortex Flowmeter	84C
Body Style	
Flanged	F
Nominal Line Size	
3/4 in (DN15, 15 mm) Line Size	008
1 in (DN25, 25 mm) Line Size	010
1 1/2 in (DN40, 40 mm) Line Size	015
2 in (DN50, 50 mm) Line Size	020
3 in (DN80, 80 mm) Line Size	030
4 in (DN100, 100 mm) Line Size	040
6 in (DN150, 150 mm) Line Size	060
8 in (DN200, 200 mm) Line Size (a)	080
10 in (DN250, 250 mm) Line Size	100
12 in (DN300, 300 mm) Line Size	120
Electronics Version	
HART Communication Protocol, 4-20 mA, and Pulse	-T
Low Power with HART Communication Protocol, output fixed at 10 mA	-L
Pulse Output	
Standard pulse output capability	P
Body, Flange, and Shedder Bar Material	
316 ss and 316/304 ss:	R
<ul style="list-style-type: none"> ▶ For line sizes 008 to 040, cast 316 ss (CF8M) body and shedder bar with 316 ss flanges ▶ For line sizes 060 to 080, cast 316 ss (CF8M) body and shedder bar with 304 ss flanges 	
304 ss:	E
<ul style="list-style-type: none"> ▶ For line sizes 100 to 120, fabricated 304 ss body and shedder bar with 304 ss flanges 	
316 ss with face-to-face lengths backward compatible with Style A Model 84 Vortex flowmeters: (b)	Y
<ul style="list-style-type: none"> ▶ For line sizes 008 to 040, cast 316 ss (CF8M) body and shedder bar with 316 ss flanges (Line sizes 060 to 120 already have backward compatible face-to-face lengths) 	

MODEL CODE-FLANGED BODY (CONTINUED)

Description	Model
End Connections and Flange Rating	
ANSI Class 150 RF	F1
ANSI Class 300 RF	F2
ANSI Class 600 RF	F3
ANSI Class 900 RF (not available with line sizes 100 and 120)	F4
ANSI Class 1500 RF (not available with line sizes 100 and 120)	F5
ANSI Class 150 RTJ (not available with line size 008)	T1
ANSI Class 300 RTJ	T2
ANSI Class 600 RTJ	T3
ANSI Class 900 RTJ (not available with line sizes 100 and 120)	T4
ANSI Class 1500 RTJ (not available with line sizes 100 and 120)	T5
PN16 EN1092-1 Raised Face Type "D" Nut Groove (available with line sizes 060 to 120 only)	D1
PN25 EN1092-1 Raised Face Type "D" Nut Groove (available with line sizes 080 to 120 only)	D2
PN40 EN1092-1 Raised Face Type "D" Nut Groove	D3
PN63 EN1092-1 Raised Face Type "D" Nut Groove (available with line sizes 020 to 120) (c)	D6
PN100 EN1092-1 Raised Face Type "D" Nut Groove	D7
PN160 EN1092-1 Raised Face Type "D" Nut Groove (not available with line sizes 008, 100, 120)	D5
PN16 EN1092-1 Raised Face Finish Type B1 (available with line sizes 060 to 120 only)	B1
PN25 EN1092-1 Raised Face Finish Type B1 (available with line sizes 080 to 120 only)	B2
PN40 EN1092-1 Raised Face Finish Type B1	B3
PN63 EN1092-1 Raised Face Finish Type B2 (d)	B6
PN100 EN1092-1 Raised Face Finish Type B2	B7
PN160 EN1092-1 Raised Face Finish Type B2 (not available with line sizes 008, 100, 120)	B5
PN40 EN1092-1 Raised Face Finish Type F	C3
PN100 EN1092-1 Raised Face Finish Type F	C7
Single or Dual Measurement and Isolation Manifold	
Single Measurement; No Isolation Manifold	S
Multivariable Selection	
Temperature compensation only (up to 500°F/260°C maximum with Multivariable Selection T) (e) (f)	T
Sensor Fill, Temperature Range, and Material (f)	
Standard Temperature Range (with Fill Fluid)	
Fluorolube Fill, 0° to 200°F (-18° to +93°C) Nickel alloy CW2M (g)	D
Fluorolube Fill, 0° to 200°F (-18° to +93°C) Stainless Steel CF3M	F
Silicone Fill, 0° to 400°F (-18° to +204°C) Nickel alloy CW2M (g)	R
Silicone Fill, 0° to 400°F (-18° to +204°C) Stainless Steel CF3M	S
Extended Temperature Range (No Fill Fluid)	
Unfilled, 300° to 700°F (149° to 371°C) Nickel alloy CW2M (g)	A
Sensor Options A and B are rated to 500°F (260°C) maximum with Multivariable Selection T	
Unfilled, 300° to 700°F (149° to 371°C) Stainless Steel CF3M	B
Sensor Options A and B are rated to 500°F (260°C) maximum with Multivariable Selection T	
Mounting and Conduit Openings for Electrical Housing	
Aluminum Integral Top Mounted 1/2-NPT Conduit Connections	T
Aluminum Integral Top Mounted M20 Conduit Connections	V
Aluminum Remote Mounted 1/2-NPT Conduit Connections (h)	R
Aluminum Remote Mounted M20 Conduit Connections (h)	W

MODEL CODE-FLANGED BODY (CONTINUED)

Description	Model
Local Digital Indicator/Configurator	
No Digital Indicator/Configurator	N
Full Function Digital Indicator/Configurator	J
Electrical Safety (refer to "ELECTRICAL SAFETY SPECIFICATIONS" for details) (i)	
ATEX intrinsically safe	AA
ATEX flameproof	AD
INMETRO intrinsically safe	BA
INMETRO flameproof	BD
CSA intrinsically safe	CA
CSA explosionproof	CD
CSA Division 2	CN
IECEX intrinsically safe	EA
IECEX flameproof	ED
FM intrinsically safe	FA
FM explosionproof	FD
FM nonincendive	FN
EAC intrinsically safe	RA
EAC flameproof	RD
Unit with CE mark, PED, controls and records	YY
Unit does not have CE mark; not to be installed in European Union (EU) countries	ZZ
Optional Selections	
Cable Length Selection for Remote Electronics Housing	
20 ft (6 m) Cable to Connect to Remote Electronics Housing	-B
30 ft (9 m) Cable to Connect to Remote Electronics Housing	-D
40 ft (12 m) Cable to Connect to Remote Electronics Housing	-E
50 ft (15 m) Cable to Connect to Remote Electronics Housing	-G
Instruction Manual	
Instruction Manual in hard copy format (j)	-C
Foxboro Certificates of Compliance/Conformance	
Standard Certificate of Compliance	-L
Foxboro Material Certification of Process Wetted Metal (Conforms to EN 10204 Type 3.1 certificate)	-M
Process Wetted Parts Comply with NACE Standards MR-0175-2003 and MR-0103-2007	-Q
Foxboro Calibration Certificate	
Calibration and Pressure Test Certified Copy	-N
Cable Connectors – with Electronics Housing Codes T and R only (1/2 NPT)	
Hawke Cable Gland (available only with electrical safety codes YY and ZZ)	-P
PG11 Cable Gland, Trumpet Shaped (not available with explosion proof/flameproof certifications)	-R
Welding Certificate (select only one option)	
Welding certified to conform to ASME Boiler and Pressure Vessel Code, Section IX	-F
Welding certified to conform to ASME Boiler and Pressure Vessel Code, Section IX and Radiographic Examination (X-Ray) of welds	-X
Cleaning for Oxygen/Chlorine Service	
Cleaning of Process Wetted Parts per Compressed Gas Association's CGA G-4.1 and ASTM G93 - Contact Global Customer Support for availability with line sizes 100 to 120	-H
Tamperproof and Custody Transfer Options	
Tamperproof sealing for housing and covers	-A
Sensor Plating (for Hydrogen applications)	
Gold Plated Sensor	-J

MODEL CODE-FLANGED BODY (CONTINUED)

Description	Model
<p>Optional Conduit Fitting Adapter for use with 1/2 NPT conduit (Available only with Remote Mounted Housing Code R) Example: 84CF020-TPRF1STDTJYY-N</p>	<p>-T</p>

- a. For Line Size 008 with F4, F5, T4, T5, D5, B5 End Connections, Welding Certificate Option -X is included.
- b. Body, Flange, and Shedder Bar Material Selection Y is recommended only for replacement of Style A flowmeters that have lay-length differences greater than ±0.13 in (±5 mm).
- c. For Line Sizes 008, 010, and 015, select End Connection D7.
- d. For Line Sizes 008, 010, and 015, select End Connection B7.
- e. For multi-variable selection T, pulse output is always enabled.
- f. Multivariable Option T allows for up to 500°F (260°C). The temperature element of the RTD is rated only up to 500°F (260°C). Use care when using a Vortex high temperature sensor, which may be rated to a higher temperature.
- g. Equivalent to Hastelloy® C-4C.
- h. For remote mounting, select optional cable length.
- i. The Model 84C has been designed to meet the electrical safety descriptions listed in this table. For detailed information, or status of the testing laboratory approval/certification, contact Global Customer Service.
- j. A DVD containing the documentation set is shipped standard with the product.

MODEL CODE-WAFER BODY

Description	Model
Vortex Flowmeter	84C
Body Style	
Wafer	W
Nominal Line Size	
3/4 in (DN15, 15 mm) Line Size	008
1 in (DN25, 25 mm) Line Size	010
1 1/2 in (DN40, 40 mm) Line Size	015
2 in (DN50, 50 mm) Line Size	020
3 in (DN80, 80 mm) Line Size	030
4 in (DN100, 100 mm) Line Size	040
6 in (DN150, 150 mm) Line Size	060
8 in (DN200, 200 mm) Line Size	080
Electronics Version	
HART Communication Protocol	-T
Low Power with HART Communication Protocol, output fixed at 10 mA	-L
Pulse Output	
Standard pulse output capability	P
Body, Flange, and Shedder Bar Material	
316 ss, ASTM A351-CF8M (316) Cast Body and Shedder	R
ASTM A494-CW2M (Nickel alloy (a))	H
▶ For line sizes 008 to 040 only	
Mounting and Centering System	
▶ Centering for ANSI Class 150, 300, and 600 flanges (Line sizes 008 to 040)	W1
▶ Centering for PN16 flanges (Line sizes 010 to 030)	
▶ Centering for PN40 (Line sizes 010 to 030, 060, and 080)	
▶ Centering PN63 and PN100 (All sizes)	
Centering for ANSI Class 600 flange (Line sizes 060 to 080 only)	W3
Centering for PN16 flange (Line sizes 040 to 080 only)	W4
Centering for PN40 only (Line size 040 only)	W5
Centering for Metric PN16 and PN40 (Line size 008 only)	W9
Single or Dual Measurement and Isolation Manifold	
Single Measurement; No Isolation Manifold	S
Multivariable Selection	
Temperature compensation only (up to 500°F/260°C maximum with Multivariable Selection T) (b) (c)	T
Sensor Fill, Temperature Range, and Material	
Standard Temperature Range (with Fill Fluid)	
Fluorolube Fill, 0° to 200°F (-18° to +93°C) Nickel alloy (a)	D
Fluorolube Fill, 0° to 200°F (-18° to +93°C) Stainless Steel CF3M	F
Silicone Fill, 0° to 400°F (-18° to +204°C) Nickel alloy CW2M (a)	R
Silicone Fill, 0° to 400°F (-18° to +204°C) Stainless Steel CF3M	S
Extended Temperature Range (No Fill Fluid)	
Unfilled, 300° to 800°F (149° to 427°C) Nickel alloy CW2M (a) (c)	E
For Multivariable Selection T, sensor is rated to 500°F (260°C) maximum	
Unfilled, 300° to 800°F (149° to 427°C) Stainless Steel CF3M (c)	G
For Multivariable Selection T, sensor is rated to 500°F (260°C) maximum	
Mounting and Conduit Openings for Electrical Housing	
Aluminum Integral Top Mounted with 1/2-NPT Conduit Connections	T
Aluminum Integral Top Mounted with M20 Conduit Connections	V
Aluminum Remote Mounted, 1/2-NPT Conduit Connections (d)	R
Aluminum Remote Mounted M20 Conduit Connections (d)	W

MODEL CODE-WAFER BODY (CONTINUED)

Description	Model
Local Digital Indicator/Configurator	
No Digital Indicator/Configurator (blind only)	N
Full Function Digital Indicator/Configurator	J
Electrical Safety (refer to "ELECTRICAL SAFETY SPECIFICATIONS" for details) (e)	
ATEX intrinsically safe	AA
ATEX flameproof	AD
INMETRO intrinsically safe	BA
INMETRO flameproof	BD
CSA intrinsically safe	CA
CSA explosionproof	CD
CSA Division 2	CN
IECEX intrinsically safe	EA
IECEX flameproof	ED
FM intrinsically safe	FA
FM explosionproof	FD
FM nonincendive	FN
EAC intrinsically safe	RA
EAC flameproof	RD
Unit with CE mark, PED, controls and records	YY
Unit does not have CE mark; not to be installed in European Union (EU) countries	ZZ
Optional Selections	
Cable Length Selection for Remote Mounted Electronics	
20 ft (6 m) Cable to Connect to Remote Electronics Housing	-B
30 ft (9 m) Cable to Connect to Remote Electronics Housing	-D
40 ft (12 m) Cable to Connect to Remote Electronics Housing	-E
50 ft (15 m) Cable to Connect to Remote Electronics Housing	-G
Instruction Manual	
Detailed Instruction Manual in hard copy format (f)	-C
Foxboro Certificates of Compliance/Conformance	
Standard Certificate of Compliance	-L
Foxboro Material Certification of Process Wetted Metal (Conforms to EN 10204 Type 3.1 certificate)	-M
Process Wetted Parts Comply with NACE Standards MR-0175-2003 and MR-0103-2007	-Q
Foxboro Calibration Certificate	
Calibration and Pressure Test Certified Copy	-N
Cable Connectors – with Electronics Housing Codes T and R only (1/2 NPT)	
Hawke Cable Gland (available only with electrical safety codes YY and ZZ)	-P
PG11 Cable Gland, Trumpet Shaped (not available with explosionproof/flameproof certifications)	-R
Cleaning for Oxygen/Chlorine Service	
Cleaning of Process Wetted Parts per Compressed Gas Association's CGA G-4.1 and ASTM G93	-H
Tamperproof and Custody Transfer Options	
Tamperproof sealing for housing and covers	-A
Sensor Plating	
Gold Plated Sensor	-J
Optional Conduit Fitting	
Adapter for use with 1/2 NPT conduit (Available only with Remote Mounted Housing Code R)	-T
Example: 84CW020-TPRW1STDTJYY-N	

a. Equivalent to Hastelloy C-4C.

b. Pulse output option is required for temperature compensated vortex.

- c. Multivariable Option T allows for up to 500°F (260°C). The temperature element of the RTD is rated only up to 500°F (260°C). Use care when using a Vortex high temperature sensor, which may be rated to a higher temperature.
- d. For remote mounting, select optional cable length.
- e. The Model 84C has been designed to meet the electrical safety descriptions listed in this table. For detailed information, or status of the testing laboratory approval/certification, contact Global Customer Service.
- f. A DVD containing the documentation set is shipped standard with the product.

DIMENSIONS – NOMINAL (FLANGED BODY)

84C FLANGED BODY FLOWMETER WITH INTEGRALLY MOUNTED ELECTRONICS

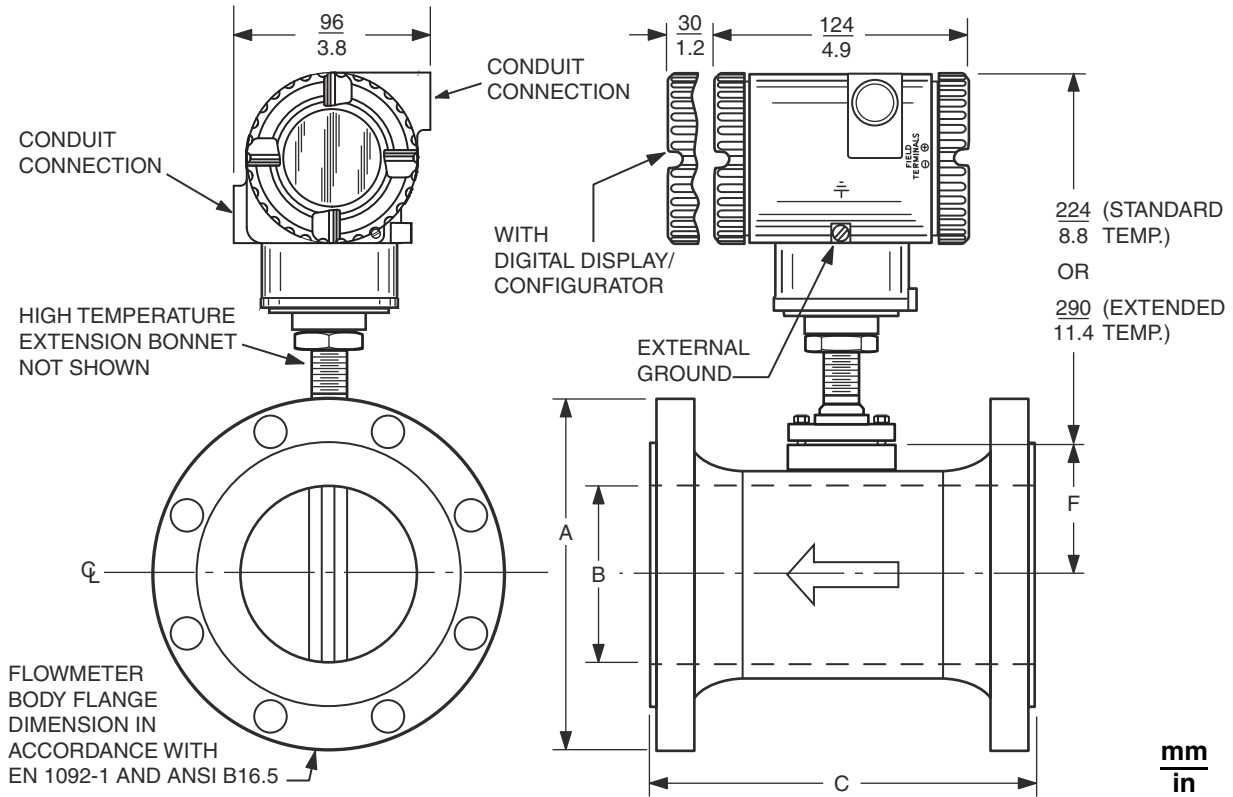

Refer to Table 14, Table 15, and Table 16 for dimensions A, B, C, and F.

REMOTELY MOUNTED ELECTRONICS HOUSING - FLANGED BODY

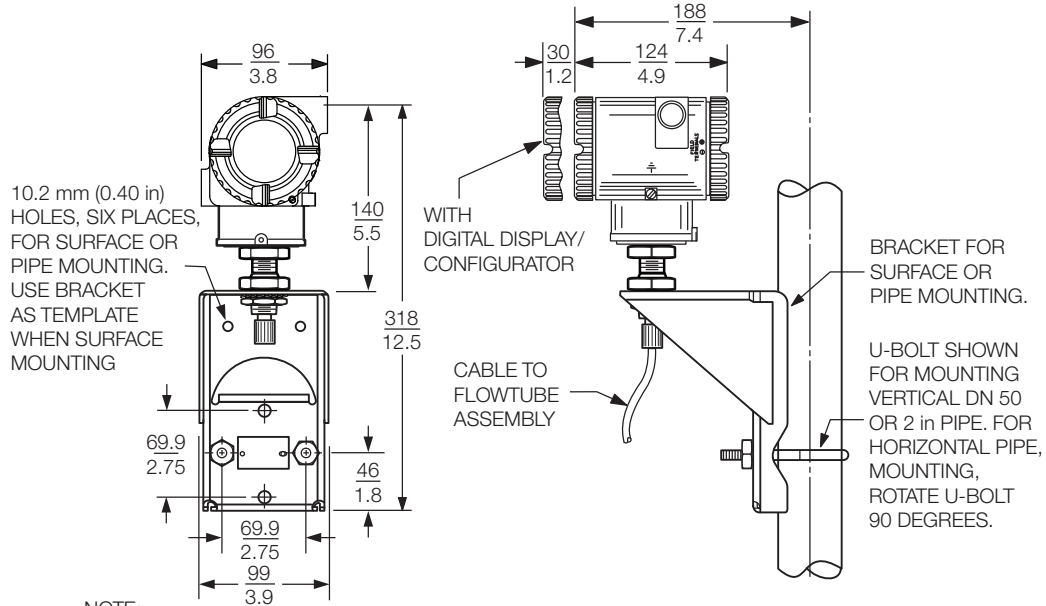

NOTE:

WHEN THE BRACKET IS USED FOR WALL MOUNTING, REPLACE U-BOLT WITH TWO (OR FOUR IF NECESSARY) 0.375 IN BOLTS OF SUFFICIENT LENGTH TO PASS THROUGH THE BRACKET AND SURFACE

INTEGRAL JUNCTION BOX AND REMOTELY MOUNTED ELECTRONICS HOUSING

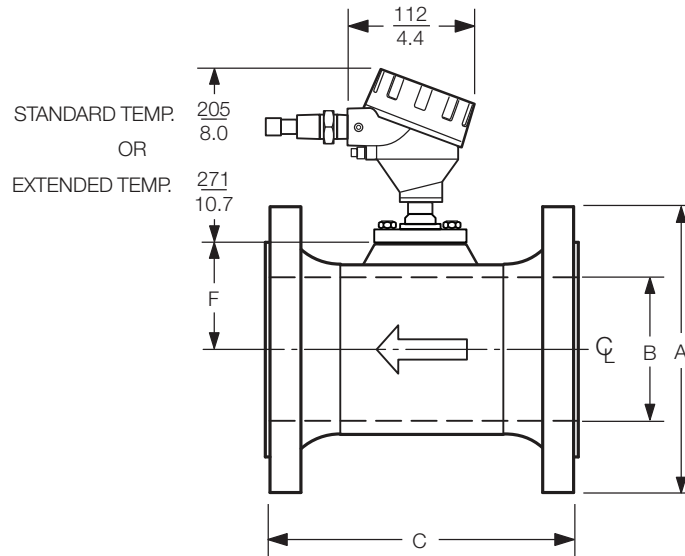

Refer to Table 14, Table 15, and Table 16 for dimensions A, B, C, and F.

Face-to-Face Dimension “C”- 84C Flanged Body

Before installing your flowmeter, check its data plate to determine its style: A, B or C. The style indicator (ST) on the data plate is illustrated in Figure 6.

Tables 14 and 15 provide face-to-face lengths of Model 84C flanged flowmeters with Body, Flange, and Shedder Bar Material model code selections R and E. The face-to-face lengths of these 84C flowmeters have matching face-to-face lengths as Model 84 Style B flanged flowmeters.

Table 16 provides face-to-face lengths of Model 84C flanged flowmeters with Body, Flange, and Shedder Bar Material model code selection Y. The face-to-face lengths of these 84C flowmeters have matching face-to-face lengths as Model 84 Style A flanged flowmeters. Use model code selection Y **only** to replace Style A flowmeters.

Figure 6. Flowmeter Data Plate

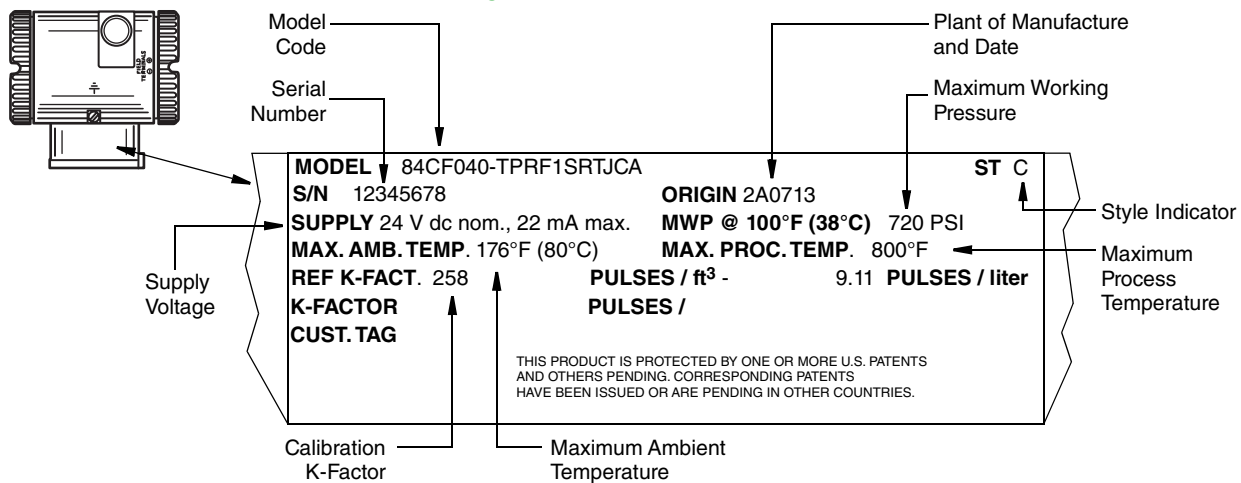

Table 14. 84C Single Measurement Configuration With ANSI Flanges and Integral Housing; Body, Flange, and Shedder Bar Material Model Code Selections R and E

Nominal Line Size	Flange Type	Dimensions in Inches				
		A (O.D.)	B (I.D.)	C (a) RF	C (a) RTJ	F
3/4 in	Class 150	3.88	0.74	6.56	--	1.82
	Class 300	4.62	0.74	6.94	7.32	1.82
	Class 600	4.62	0.74	7.44	7.44	1.82
	Class 900	5.12	0.74	8.44	8.44	1.82
	Class 1500	5.12	0.74	8.44	8.44	1.82
1 in	Class 150	4.25	0.96	6.80	7.18	1.93
	Class 300	4.88	0.96	7.32	7.70	1.93
	Class 600	4.88	0.96	7.82	7.82	1.93
	Class 900	5.88	0.96	8.7	8.70	1.93
	Class 1500	5.88	0.96	8.7	8.70	1.93

Table 14. 84C Single Measurement Configuration With ANSI Flanges and Integral Housing; Body, Flange, and Shedder Bar Material Model Code Selections R and E (Continued)

Nominal Line Size	Flange Type	Dimensions in Inches				
		A (O.D.)	B (I.D.)	C (a) RF	C (a) RTJ	F
1 1/2 in	Class 150	4.62	1.50	7.32	7.70	2.20
	Class 300	6.12	1.50	7.82	8.20	2.20
	Class 600	6.12	1.50	8.44	8.44	2.20
	Class 900	7.00	1.50	9.44	9.44	2.20
	Class 1500	7.00	1.50	9.44	9.44	2.20
2 in	Class 150	6.00	1.94	7.75	8.13	2.32
	Class 300	6.50	1.94	8.25	8.75	2.32
	Class 600	6.50	1.94	9.01	9.13	2.32
	Class 900	8.50	1.94	11.25	11.37	2.32
	Class 1500	8.50	1.69	11.25	11.37	2.20
3 in	Class 150	7.50	2.87	8.88	9.26	2.75
	Class 300	8.25	2.87	9.62	10.12	2.75
	Class 600	8.25	2.87	10.38	10.50	2.75
	Class 900	9.50	2.87	11.88	12.00	2.75
	Class 1500	10.50	2.63	13.12	13.25	2.62
4 in	Class 150	9.00	3.83	9.62	10.00	3.35
	Class 300	10.00	3.83	10.38	10.88	3.35
	Class 600	10.75	3.83	12.12	12.24	3.35
	Class 900	11.50	3.83	13.12	13.24	3.35
	Class 1500	12.25	3.44	13.88	14.00	3.35
6 in	Class 150	11.00	5.76	12.00	12.38	4.42
	Class 300	12.50	5.76	12.76	13.26	4.42
	Class 600	14.00	5.76	14.74	14.86	4.42
	Class 900	15.00	5.19	16.5	16.62	4.42
	Class 1500	15.50	5.19	19.00	19.25	4.42
8 in	Class 150	13.50	7.63	15.00	15.38	5.47
	Class 300	15.00	7.63	15.75	16.26	5.47
	Class 600	16.50	7.63	18.00	18.12	5.47
	Class 900	18.50	6.81	20.26	20.38	5.47
	Class 1500	19.00	6.81	24.26	24.64	5.47
10 in	Class 150	16.00	9.56	15.00	15.38	6.55
	Class 300	17.50	9.56	16.24	16.74	6.55
	Class 600	20.00	9.56	19.5	19.62	6.55
12 in	Class 150	19.00	11.37	17.00	17.38	7.55
	Class 300	20.50	11.37	18.24	18.74	7.55
	Class 600	22.00	11.37	20.74	20.76	7.55

a. Overall length "C" is ±0.250 in (±6.4 mm).

Table 15. 84C Single Measurement Configuration With DIN Flanges and Integral Housing; Body, Flange, and Shedder Bar Material Model Code Selections R and E

Nominal Line Size	Flange Type	Dimensions in mm			
		A (O.D.)	B (I.D.)	C (a)	F
15 mm	PN 40 (b)	95.00	18.80	138.00	46.20
	PN 100	105.00	18.80	152.00	46.20
25 mm	PN 40 (b)	115.00	24.31	142.00	49.00
	PN 100	140.00	24.31	178.00	49.00
	PN 160	140.00	24.31	178.00	49.00
40 mm	PN 40 (b)	150.00	38.10	152.00	55.90
	PN 100	170.00	38.10	186.00	55.90
	PN 160	170.00	38.10	190.00	55.90
50 mm	PN 40 (b)	165.00	49.20	166.00	58.90
	PN 63	180.00	49.20	194.00	58.90
	PN 100	195.00	49.20	206.00	58.90
	PN 160	195.00	49.20	220.00	58.90
80 mm	PN 40 (b)	200.00	72.90	202.00	69.90
	PN 63	215.00	72.90	230.00	69.90
	PN 100	230.00	72.90	242.00	69.90
	PN 160	230.00	72.90	258.00	69.90
100 mm	PN 40 (b)	235.00	97.18	222.00	85.10
	PN 63	250.00	97.18	248.00	85.10
	PN 100	265.00	97.18	272.00	85.10
	PN 160	265.00	97.18	292.00	85.10
150 mm	PN 16	285.00	146.30	237.00	112.30
	PN 40 (b)	300.00	146.30	277.00	112.30
	PN 63	345.00	146.30	317.00	112.30
	PN 100	355.00	146.30	357.00	112.30
	PN 160	355.00	131.80	383.00	112.30
200 mm	PN 16	340.00	193.68	302.00	138.90
	PN 25	360.00	193.68	338.00	138.90
	PN 40	375.00	193.68	354.00	138.90
	PN 63	415.00	193.68	398.00	138.90
	PN 100	430.00	193.68	438.00	138.90
	PN 160	430.00	173.05	458.00	138.90
250 mm	PN 16	405.00	242.87	318.00	166.40
	PN 25	425.00	242.87	354.00	166.40
	PN 40	450.00	242.87	388.00	166.40
	PN 63	470.00	242.87	428.00	166.40
	PN 100	505.00	242.87	492.00	166.40

Table 15. 84C Single Measurement Configuration With DIN Flanges and Integral Housing; Body, Flange, and Shedder Bar Material Model Code Selections R and E (Continued)

Nominal Line Size	Flange Type	Dimensions in mm			
		A (O.D.)	B (I.D.)	C (a)	F
300 mm	PN 16	460.00	288.90	359.00	191.80
	PN 25	485.00	288.90	387.00	191.80
	PN 40	515.00	288.90	433.00	191.80
	PN 63	530.00	288.90	483.00	191.80
	PN 100	585.00	288.90	543.00	191.80

- a. Overall length "C" is ±6.4 mm (±0.250 in).
- b. May be used with PN 25 mating flange.

Table 16. 84C Single Measurement Configuration With ANSI Flanges and Integral Housing; Body, Flange, and Shedder Bar Material Model Code Selection Y; Backwards Compatible with Style A (a) (b)

Nominal Line Size	Flange Rating	Dimensions in Inches			
		A (O.D.)	B (I.D.)	C (c)	F
3/4 in	Class 150	3.88	0.74	6.00	1.82
	Class 300	4.62	0.74	6.00	
	Class 600	4.62	0.74	6.50	
1 in	Class 150	4.25	0.96	6.50	1.93
	Class 300	4.88	0.96	6.50	
	Class 600	4.88	0.96	7.00	
1 1/2 in	Class 150	4.62	1.50	7.25	2.20
	Class 300	6.12	1.50	7.25	
	Class 600	6.12	1.50	7.88	
2 in	Class 150	Not available			
	Class 300	6.50	1.94	7.75	2.32
	Class 600	6.50	1.94	8.50	
3 in	Class 150	Not available			
	Class 300	8.25	2.87	8.75	2.75
	Class 600	8.25	2.87	9.50	
4 in	Class 150	Not available			
	Class 300	10.00	3.83	9.50	3.35
	Class 600	10.75	3.83	10.50	

- a. Style B Vortex flowmeters with ANSI flanges contain a model code option for face-to-face lengths that are backwards compatible with Style A Vortex flowmeters. Style B model code selection "Y" matches Style A model code selection "S".
- b. Use these versions only when replacing a Model 84F Style A meter or for stocking purposes for Model 84F Style A meters.
- c. Overall length "C" is ±0.250 in (±6.4 mm).

DIMENSIONS - NOMINAL (WAFER BODY)

$\frac{\text{mm}}{\text{in}}$

84C WAFER BODY FLOWMETERS; INTEGRAL MOUNT; SINGLE MEASUREMENT

84C WAFER BODY

84C WAFER BODY

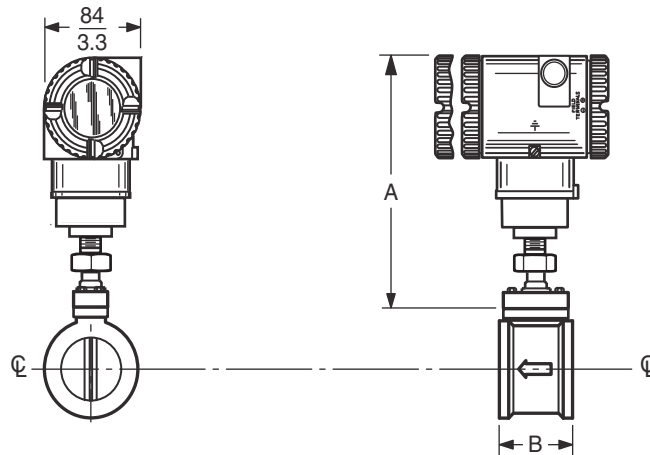

Dimension	Dimensions - Nominal Line Size Code (a)							
	008	010	015	020	030	040	060	080
A (b)	$\frac{205}{8.1}$	$\frac{205}{8.1}$	$\frac{205}{8.1}$	$\frac{205}{8.1}$	$\frac{205}{8.1}$	$\frac{205}{8.1}$	$\frac{205}{8.1}$	$\frac{205}{8.1}$
B	$\frac{79.5}{3.13}$	$\frac{79.5}{3.13}$	$\frac{79.5}{3.13}$	$\frac{79.5}{3.13}$	$\frac{95.3}{3.75}$	$\frac{120.7}{4.75}$	$\frac{177.8}{7.00}$	$\frac{228.6}{9.00}$

- a. Refer to Model Code for sizes. Also refer to DP 019-127 for 84C Wafer dimensions.
- b. Dimension A is shown with the standard temperature bonnet. A longer bonnet is used in extended temperature applications. When this selection is made, add 91.4 mm (3.6 in) to Dimension A.

84C WAFER BODY FLOWMETERS WITH REMOTE MOUNTED ELECTRONICS

mm
in

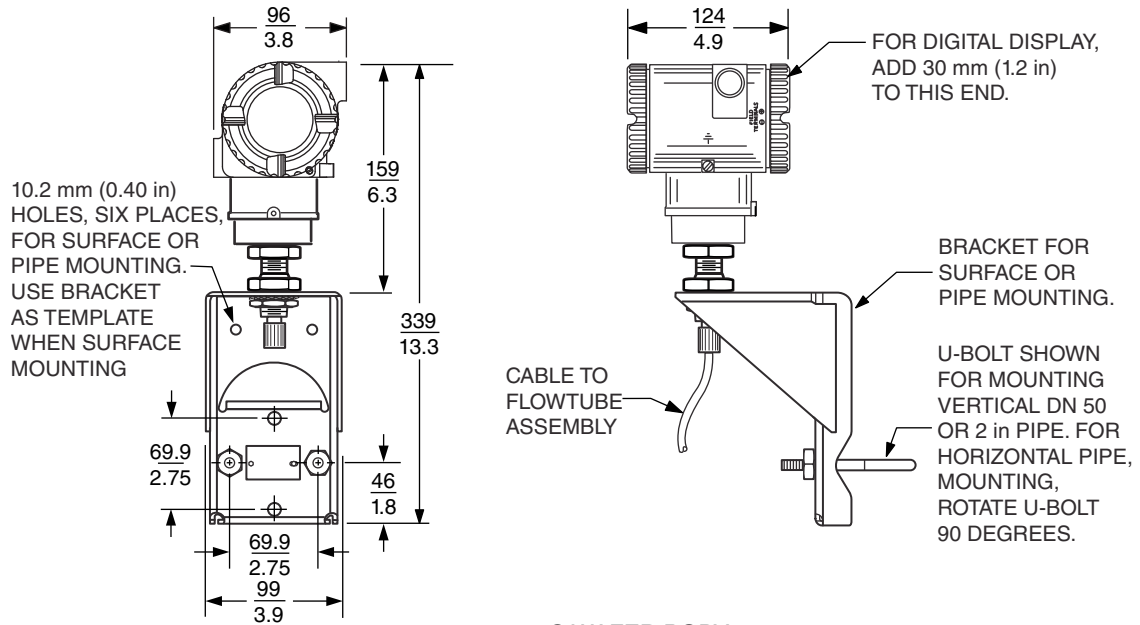

84C WAFER BODY

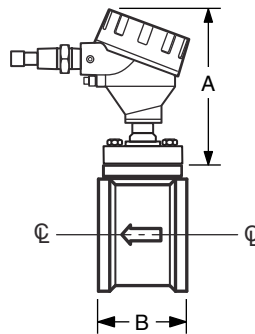

Dimension	Dimensions - Nominal Line Size Code (a)							
	008	010	015	020	030	040	060	080
A (b)	186 7.3	186 7.3	186 7.3	186 7.3	186 7.3	186 7.3	186 7.3	186 7.3
C	79.5 3.13	79.5 3.13	79.5 3.13	79.5 3.13	95.3 3.75	120.7 4.75	177.8 7.00	228.6 9.00

- a. Refer to Model Code for sizes. Also refer to DP 019-127 for 84C (Wafer Body) dimensions,
- b. Dimension A is shown with the standard temperature bonnet. A longer bonnet is used in extended temperature applications. When this selection is made, add 91.4 mm (3.6 in) to Dimension A.

NOTES



ORDERING INSTRUCTIONS

1. Model Number.
2. Flow Data:
 - a. Maximum, minimum, and normal flow rate.
 - b. Fluid composition and viscosity at operating temperatures.
 - c. Fluid density or relative density (specific gravity).
 - d. Maximum, minimum, and normal operating temperatures.
 - e. Maximum, minimum, and normal operating pressures.
 - f. Mating pipe schedule.
 - g. Type and location (distance) of upstream disturbances.
3. Calibration Information (analog output only); maximum flow rate at 20 mA output.
4. Electrical Classification.
5. Optional Selections and Accessories (see "OPTIONAL SELECTIONS AND ACCESSORIES").
6. Customer Tag Data.

FLOWEXPERTPRO SIZING APPLICATION

FlowExpertPro.com



Mobile application



OTHER FOXBORO PRODUCTS

The Foxboro product lines offer a broad range of measurement and instrument products, including solutions for pressure, flow, analytical, temperature, positioning, controlling, and recording.

For a list of these offerings, visit our web site at:

www.schneider-electric.com

Schneider Electric Systems USA, Inc.
38 Neponset Avenue
Foxboro, MA 02035
United States of America
<http://www.schneider-electric.com>

Global Customer Support
Inside U.S.: 1-866-746-6477
Outside U.S.: 1-508-549-2424
<https://pasupport.schneider-electric.com>

Copyright 2015-2017 Schneider Electric Systems USA, Inc. All rights reserved.

Invensys, Foxboro, ActiveTuning, *DirectSense*, and FlowExpertPro are trademarks of Schneider Electric Systems USA, Inc., its subsidiaries, and affiliates. All other trademarks are the property of their respective owners.

Life Is On

Foxboro[®]
by Schneider Electric