

# Fisher® Vee-Ball™ V150, V200 and V300 Rotary Control Valves

This bulletin covers the NPS 1 through 2, NPS 3 through 12 Series B, and the NPS 14 through 20 V150, V200 and V300 Vee-Ball control valves. The Vee-Ball valve combines globe valve ruggedness with the efficiency of a rotary valve. A shearing action between the V-notch ball and the ball seal (figure 1) promotes smooth, nonclogging operation. The unrestricted straight-through flow design provides high capacity for gas, steam, liquids, and fibrous slurries.

V150, V200, and V300 valves mate with a variety of ASME raised face flanges, as well as with DIN flanges (see Specifications).

To meet specific application requirements, a variety of metal and soft ball seal materials are available. A splined drive shaft combines with a variety of power operated and manual actuators to provide reliable, high-performance throttling or on-off operation for many different applications in the process industries.

Unless otherwise noted, all NACE references are to NACE MR0175-2002.



W8172-3

V150



W9161-2

V200

Typical Vee-Ball Valves with Fisher 1052 Actuators and  
FIELDVUE™ DVC6200 Digital Valve Controllers



**Specifications**

**Valve Sizes and End Connection Styles**

**V150:** NPS ■ 1, ■ 1-1/2, ■ 2, ■ 3, ■ 4, ■ 6, ■ 8, ■ 10, ■ 12, flanged valves that mate with CL150 raised-face flanges (see table 1). Also, NPS 3 through 12 mate with PN classes (see table 1)

**V150:** NPS ■ 14, ■ 16 and ■ 20: Flanged raised-face valves. NPS 14 and 16 valves are available in ASME B16.10 Short, face-to-face dimensions only (see table 1 and figure 8)

**V200:** NPS ■ 1, ■ 1-1/2, ■ 2, ■ 3, ■ 4, ■ 6, ■ 8, or ■ 10 flangeless valves that mate with ■ CL150, ■ 300, or ■ 600 raised-face flanges depending on size (see table 1)

**V300:** NPS ■ 1, ■ 1-1/2, ■ 2, ■ 3, ■ 4, ■ 6, ■ 8, ■ 10, ■ 12, ■ 14, and ■ 16 valves mate with CL300 raised-face flanges. Also some sizes mate with PN classes (see table 1)

**Maximum Inlet Pressures<sup>(1)</sup>**

**V150 or V300 Steel, CF3M (316L Stainless Steel) or CG8M (317 Stainless Steel) Valves:** Consistent with CL150 for V150, or CL300 for V300, pressure-temperature ratings per ASME B16.34 or with PN pressure-temperature ratings shown in table 1 but do not exceed the material temperature capabilities shown below or the pressure drop limitations. CF3M is available in all areas and is the standard material offering in Europe.

**V200 Steel and CG8M (317 Stainless Steel) Valves:** Consistent with applicable pressure-temperature ratings in table 1 per ASME B16.34, but do not exceed the material temperature capabilities shown below and the pressure drop limitations.

**CW2M Valves:** Consistent with applicable pressure-temperature ratings shown in table 6, but do not exceed the material temperature capabilities shown below and the pressure drop limitations.

**Maximum Shutoff Pressure/Temperature Ratings<sup>(1)</sup>**

**Composition (Fisher TCM Plus or TCM Ultra), Flat Metal (NPS 3 through 12 valves only), HD and High Temperature HD Metal Ball Seals and Flow Ring:** See table 8.

**Shutoff Classification<sup>(1)</sup>**

**Fisher TCM Plus or Ultra Ball Seal (Forward Flow):** Class VI per ANSI/FCI 70-2 and per IEC 60534-4,

**Flat Metal Ball Seal for NPS 3 through 12 valves only (Forward Flow):** Class IV per ANSI/FCI 70-2 and per IEC 60534-4,

**HD (Heavy Duty) Metal Ball Seal (Bidirectional Flow):** 0.01% of valve capacity; Class IV per ANSI/FCI 70-2 and IEC 60534-4; Maximum allowable pressure drop in reverse flow is 6.9 bar (100 psi);

**High Temperature HD (Heavy Duty) Metal Seal (Bidirectional Flow):** Class III per ANSI/FCI 70-2 and IEC 60534-4

**Flow Ring Construction (Bidirectional Flow):** 5% of valve capacity at full travel

**Micro-Notch Ball:** Same leakage as standard ball

**Construction Materials**

See tables 3, 4 and 5

**Temperature Capabilities<sup>(1,2)</sup>**

**Composition Seals (Fisher TCM Plus or TCM Ultra):** -46 to 232°C (-50 to 450°F)

**HD Metal Seals:** -46 to 288°C (-50 to 550°F)

**High Temperature HD Metal Seal:** 288 to 427°C (550 to 800°F). Contact your Emerson Process Management sales office if higher temperatures are required.

**Ceramic Micro-Notch Ball:** -46 to 93°C (-50 to 200°F)<sup>(4)</sup>

**Flow Ring or Flat Metal Seal :** -198 to 425°C (-325 to 800°F)

**PEEK/PTFE Bearings:** -198 to 260°C (-325 to 500°F)

**Packing Constructions**

**PTFE V-ring:** -46 to 232°C (-50 to 450°F)

**Graphite:** -198 to 538°C (-325 to 1000°F)

**ENVIRO-SEAL™ Single PTFE V-ring:** -46 to 232°C (-50 to 450°F)

**ENVIRO-SEAL Graphite:** -7 to 316°C (20 to 600°F)

**Flow Characteristic**

Modified equal percentage

**Dimensions**

See figures 5, 6, and 7 for dimensions

**Optional Face-to-Face Dimensions**

■ ASME B16.10 short face-to-face dimensions are available as an option for NPS 1 through 12 valves. Note that ASME B16.10 short dimensions are actually longer than ISA S75.04. See figure 8 for dimensions.

(continued)

## Specifications (continued)

### Standard Flow Direction

Forward (into the convex face of the V-notch ball)

### Flow Coefficients

See Catalog 12

### Flow Coefficient Ratio<sup>(3)</sup>

See Catalog 12

### Noise Levels

See Catalog 12

### Maximum Ball Rotation

90 degrees

### Actuator Mounting

Standard valve construction is for right-hand mounting, as viewed from upstream end of valve. Left-hand (optional) mounting is available upon request.

### Valve/Actuator Action

With diaphragm or piston rotary actuator, the valve is field-reversible between PDTC or PDO:

- push-down-to-close (extending actuator rod closes valve) and
- push-down-to-open (extending actuator rod opens valve)

### Approximate Weight

See table 2

### Options

- Pipe plug at end of follower shaft for all sizes,
- Line flange bolting, ■ Materials that are compatible with NACE MR0175-2002 for sour service (see table 5), ■ Alloy construction materials,
- ENVIRO-SEAL packing system: See figure 4 and Bulletin 59.3:041, ENVIRO-SEAL Packing Systems for Rotary Valves for more information, ■ Micro-Notch construction for NPS 1 valves (see Micro-Notch Construction section),
- S31254/CK3MCuN trim material

1. The pressure/temperature limits in this bulletin, and any applicable code or standard limitation, should not be exceeded.

2. Additional limits are shown in tables 6, 7 and 8.

3. Ratio of maximum flow coefficients to minimum usable flow coefficient can also be called rangeability.

4. For the CG&M and alloy 6 Micro-Notch constructions, pressure and temperature capabilities are the same as for standard constructions.

## Features

- **Trim Versatility**—Trim components are interchangeable between V150, V200, and V300 valves. This feature allows you to reduce your spare parts inventory and maintenance procedures. The seal assembly can be changed without removing the actuator or without removing the ball from the valve body.
- **Easy Installation**—Flanged body design of the V150 and V300 eliminates exposed line flange bolting, reduces alignment and installation time, and promotes secure valve installations and piping integrity.
- **Application Versatility**—The valves are available with ISA S75.04 and IEC 534-3-2 face-to-face dimensions as a standard construction, and optional ASME B16.10 short face-to-face dimensions. IEC 534.3.2 face-to-face dimensions are equivalent to S75.04 face-to-face dimensions.
- **Long Service Life**—The solid HD metal seal (figures 1 and 2) construction provides long service life in demanding applications. The constant wiping action of the seal across the ball's sealing surface prevents scale and sludge buildup, and provides excellent service on steam, gases, slurries, and various liquid applications.
- **Smooth Valve Operation**—Precision machined parts and pressure balanced seal designs allow smooth, precise movement of the ball.

Table 1. Valve Body Materials, End Connections, and Ratings

VALVE DESIGN	VALVE BODY MATERIAL	SIZE	RATINGS	SIZE	RATINGS
		NPS		DN	PN
V150	CF3M	1, 1-1/2, 2, 3, 4, 6, 8, 10, 12	CL150	---	---
	EN STL 1.0619, EN SST 1.4581, or EN SST 1.4408 <sup>(1)</sup>	---	---	DN 25, 40, 50, 80, 100, 150, 200, 250	PN 10/16
		---	---	DN 300	PN 16
	WCC or CW2M	1, 1-1/2, 2, 3, 4, 6, 8, 10	CL150	DN 25, 40, 50, 80, 100, 150, 200, 250	PN 10/16
		12, 16, 20	CL150	DN 300	PN 16
		14	CL150	---	---
	CG8M	1, 1-1/2, 2, 3, 4, 6, 8, 10, 12 and 14	CL150	---	---
CK3MCUN	1, 1-1/2, 2, 3, 4, 6, 8, 10 and 12	CL150	---	---	
V200	CF3M	1, 1-1/2, 2	CL150/300/600 raised-face	Not Available	Not Available
	WCC, CG8M, or CW2M	3, 4	CL150 and CL300/600 raised-face		
		6, 8	CL150/300 and CL600 raised-face		
		10	CL150 raised-face		
	M35-1	1, 1-1/2, 2, 3, 4, 6, 8	CL150, 300 and 600		
	CK3MCUN	1, 1-1/2, 2, 3, 4, 6, 8	CL150, 300 and 600		
		10	CL150		
V300	CF3M	1, 1-1/2, 2, 3, 4, 6, 8, 10, 12	CL300	---	---
	WCC or CW2M	1, 1-1/2, 2, 3, 4, 6, 8, 10, 12, 14, 16	CL300	---	---
	EN STL 1.0619, EN SST 1.4581, or EN SST 1.4408 <sup>(1)</sup>	---	---	DN 25, 40, 50, 80, and 100	PN 25/40
	CG8M	1, 1-1/2, 2, 3, 4, 6, 8, 10, 12, 14, 16	CL300	---	---
	M35-1	1, 1-1/2, 2, 3, 4, 6, 8	CL300	---	---

1. 216 WCC and EN Stl 1.0619 are dual certified. CF3M and EN SST 1.4408 are dual certified.

- **Excellent Flow Control**—Precise contouring of the Vee-Ball provides a modified equal percentage flow characteristic. For very precise control of low flow rates, the Micro-Notch option is available on the NPS 1 valve. See the Micro-Notch Construction section of this bulletin for more information.
- **Sour Service Capability**—Materials are available for applications handling sour service. These materials comply with the requirements of NACE MR0175-2002.
- **Quick and Easy Maintenance**—Ball seal inspection and replacement is done at the valve body inlet without removing the actuator or disassembling the valve. Valve maintenance requires no special tools.
- **Structural Integrity**—One-piece valve body improves structural integrity of the pressure boundary by eliminating leak paths that could be caused by the gaskets in two-piece, bolted valve designs.
- **Exceptional Environmental Capabilities**—The optional ENVIRO-SEAL packing systems are designed with very smooth shaft surfaces and live loading to provide exceptional sealing. The seal of the ENVIRO-SEAL system can restrict emissions to less than the EPA (Environmental Protection Agency) limit of 100 ppm (parts per million).

Figure 1. Vee-Ball Construction Features, Seals (Fisher V150 Shown)

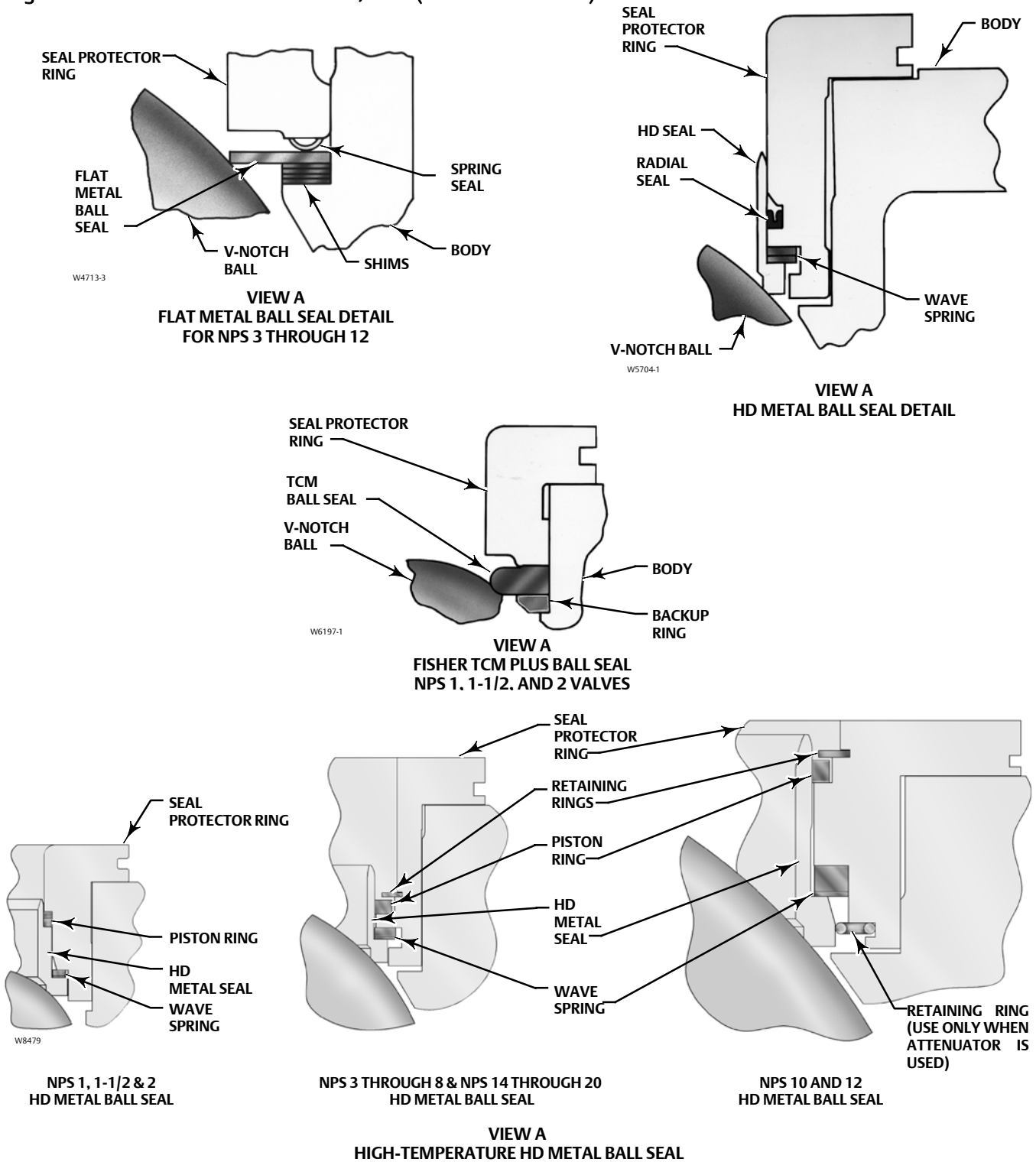
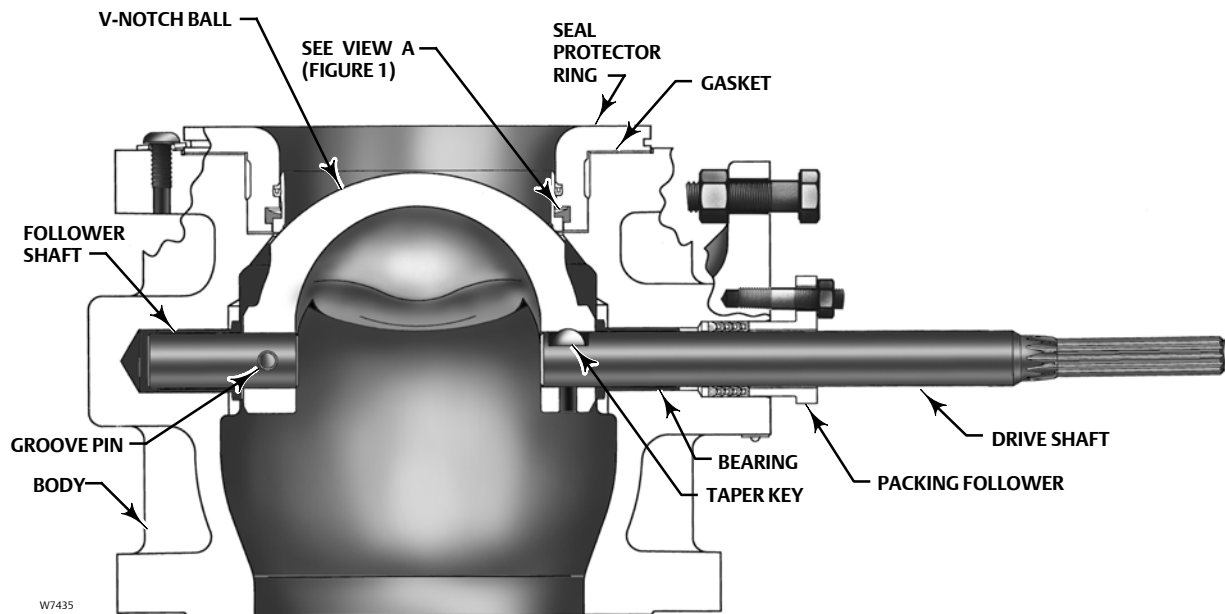
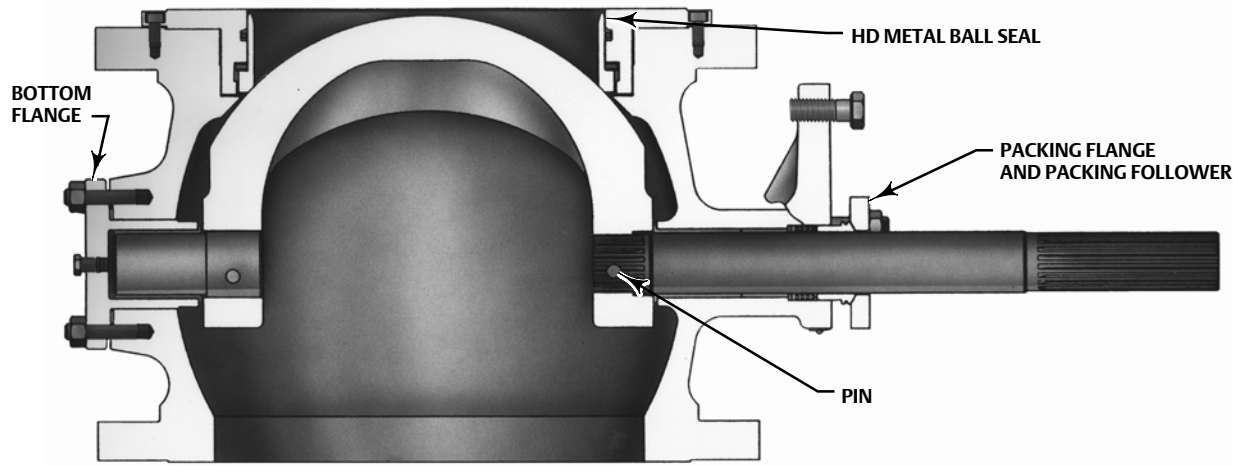

Figure 2. Vee-Ball Construction Features (Fisher V150 Shown)



NPS 3 THROUGH 12 VALVES  
(HD BALL SEAL SHOWN)



NPS 14, 16, AND 20 VALVES  
(HD METAL BALL SEAL)

**Table 2. Valve Weights, Approximate**

VALVE SIZE, NPS	V150		V200		V300	
	kg	lbs	kg	lbs	kg	lbs
1	5.6	13	4.5	10	8	17
1-1/2	8.2	19	6.4	14	12	27
2	9.1	21	10	23	17	38
3	13	43	15	34	28	61
4	26	57	22	48	37	81
6	42	93	36	80	60	133
8	72	158	62	136	103	226
10	107	235	114	252	200	440
12	157	347	---	---	293	645
14	247	545	---	---	374	825
16	333	735	---	---	510	1125
20	524	1155	---	---	---	---

## Series B

NPS 3 through 12 have been changed to reduce parts and to improve control performance. The V-notch Ball now resembles the NPS 14 through 20 V-notch Ball. The pressed-in bushings have been eliminated, as well as the thrust washer.

## Micro-Notch Construction

For very precise control of low flow rates, the Micro-Notch construction (see figure 3) is available on NPS 1 valves. Three Micro-Notch ball materials are available: chrome-plated CG8M (317 stainless steel), solid alloy 6, and solid VTC ceramic. A VTC ceramic HD seal is standard with the VTC ceramic ball. For the CG8M and alloy 6 constructions, pressure and temperature capabilities are the same as for standard constructions. For the ceramic construction, maximum temperature is 93°C (200°F).

**Figure 3. Typical Micro-Notch Ball and Shaft**

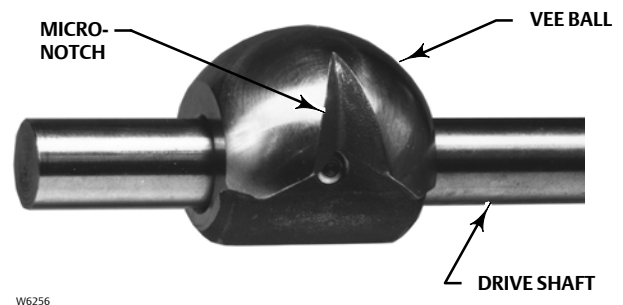

W6256

For further information, please refer to the Fisher Vee-Ball V150, V200 and V300 Rotary Control Valves NPS 1 through 12 instruction manual (D101554X012).

**Table 3. Standard Construction Materials for NPS 1 through 12 Valves**

PART		MATERIAL
Valve Body and Seal Protector Ring or Flow Ring		WCC steel (NACE), WCC steel (EN 1.0619), CG8M (317 SST, NACE), CF3M <sup>(1)</sup> (316L SST EN 1.4408 or optional EN 1.4581), CW2M (CW2M valve available with Fisher TCM Plus seal only), M35-1 or CK3MCuN
Backup Ring (NPS 1, 1-1/2 and 2 only)		CG8M (NACE), CF3M <sup>(1)</sup> (NACE) or CW2M
V-Notch Ball		CG8M (NACE), CF3M, CW2M, chromium-plated CF3M, chromium-plated CG8M(NACE) and chromium-plated CG8M1/2 CF3M with alloy 6 notch (NACE), M35-1 or CK3MCuN
Seal	Fisher TCM	Fisher TCM Plus and Fisher TCM Ultra
	Flat Metal Seal, Shims, and Spring Seal <sup>(7)</sup>	Spring Tempered S31600 (316 stainless steel) or Spring Tempered S30200 (302 stainless steel) for NPS 12 valves only
	HD (Heavy-Duty) Metal	CF10SMnN <sup>(2)</sup> , CD7MCuN <sup>(3)</sup> (alloy 255 duplex stainless steel) or R30006 (Alloy 6, NACE)
	High Temperature HD Metal Seal	R30006 (Alloy 6)
Wave Spring (use with HD seal)		N07750
HD Seal Radial Seal		Graphite reinforced PTFE
High Temp HD Seal Piston Ring		Graphite FMS 17F39
Bearings		PEEK <sup>(4)</sup> /Carbon-filled PTFE liner (NACE), S31603 Nitride, R30006 (alloy 6, NACE), silver-plated R30006, N10276 with carbon-filled PTFE liner, or N10276 with glass-filled PTFE liner
Seal Retainer Gasket		Laminated graphite
Packing		PTFE V-ring with one carbon-filled PTFE ring <sup>(5)</sup> , PTFE V-ring, or graphite ribbon. Packing is available with or without live loading.
Shafts		S20910 (NACE), S17400 (17-4PH stainless steel), N10276, N05500, or S31254 <sup>(8)</sup>
Groove Pin		S31600 (NACE) or N10276
Taper Key		R30006 <sup>(6)</sup> , S20910, or N10276
Taper Pin (NPS 1, 1-1/2, and 2 only)		S20910 (NACE) or N10276
Pipe Plug (Optional)		S31600 (NACE) N10276, or S31603 (316L stainless steel, NACE)
Seal Retainer Screws and Washers		Stainless steel
Packing Follower and Packing Box Ring		CF8M (316 stainless steel, NACE), N10276, S312254, or N10276 with separate S31600 packing box flange (NACE)
Actuator Mounting Bolts and Nuts		Grade 5 steel or strain-hardened B8M stainless steel
Spacer and Bushing		S31700 (NACE), N10276, or S31603
Packing Follower Bolting and Optional Line Bolting		SA-193-B7, SA-193-B7M, or strain-hardened SA-193-B8M

1. CF3M is available in all areas as a special order and is the standard material offered in Europe.  
2. Recommended for lubricated and non-lubricated service and where corrosion properties similar to 304 stainless steel are acceptable.  
3. Recommended for lubricated service and where corrosion properties equal to or better than 317 stainless steel are required.  
4. PEEK is poly-ether-ether-ketone.  
5. The carbon-filled PTFE ring is used for grounding.  
6. Standard material offered in North America.  
7. Offered for lubricated service only.  
8. S31254 shaft may cause the valve to be derated. Contact your Emerson Process Management sales office.

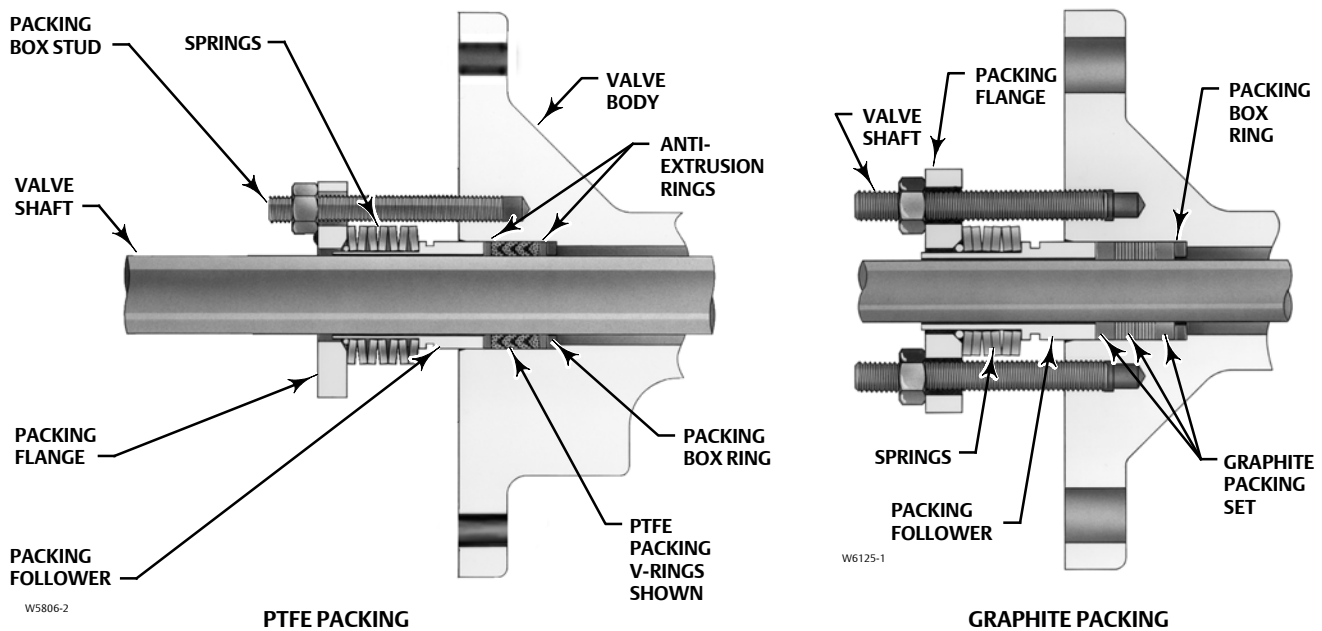

**Table 4. Standard Construction Materials for NPS 14, 16 and 20 Valves**

Part		Material
Valve Body, Seal Protector Ring, and Flow Ring		WCC steel or CG8M (317 stainless steel)
V-Notch Ball		Chromium-plated CG8M, CG8M, Chromium-plated CG8M with alloy 6 notch
Ball Seal	Fisher TCM	Fisher TCM Plus and Fisher TCM Ultra
	HD (Heavy-Duty Metal)	CF10SMnN <sup>(1)</sup> , CD7MCuM <sup>(2)</sup> (alloy 225 duplex stainless steel) or R30006 (alloy 6)
Wave Spring (use with HD seal)		N07750
Radial Seal (use with HD seal)		PTFE with N10276 spring
Bearings		PEEK/PTFE <sup>(3)</sup> , S44004 (440C stainless steel--use with S17400 [17-4PH stainless steel] shafts, alloy 6B, and silver plated alloy 6B
Thrust Washer (use with metal bearings)		Alloy 6B
Seal Retainer Gasket		Laminated Graphite
Packing		PTFE V-ring with one conductive V-ring <sup>(4)</sup> , PTFE V-ring, or graphite ribbon
Shafts		S17400 (17-4 stainless steel) or S20910
Pins		S20910
Pipe Plug		S31700 (317 stainless steel)
Packing Follower Bolting		B7M steel or strain-hardened B8M stainless steel
Retainer Screw		B8M stainless steel
Packing Follower and Packing Box ring		S31600 (316 stainless steel)
Packing Flange		Steel or S31600
Actuator Mounting Bolts and Nuts		Grade 5 steel or strain-hardened B8M stainless steel
Gasket (used with bottom flange)		S31603 (316L stainless steel) spiral wound
Stud and Hex Nut (used with bottom flange)		B7 steel or strain-hardened B8M stainless steel

1. Recommended where corrosion properties similar to 304 stainless steel are acceptable.  
 2. Recommended for lubricated service and where corrosion properties equal to or better than S31700 stainless steel.  
 3. PEEK (Poly-ether-ether-ketone) w/PTFE liner.  
 4. A carbon-filled PTFE ring is used for grounding.

**Figure 4. Typical ENVIRO-SEAL Packing Arrangements**



**Table 5. Construction Materials for Compliance with NACE MR0175-2002**

Part		Material
Valve Body and Seal Protector Ring or Flow Ring		WCC steel <sup>(1)</sup> , CG8M (317 stainless steel), CF3M <sup>(2)</sup> (316L stainless steel) or CW2M, M35-1, or CK3MCuN
Backup Ring (NPS 1, 1-1/2, and 2)		CG8M, CF3M <sup>(2)</sup> or CW2M
V-Notch Ball		Chrome-plated CG8M, CW2M, CF3M, chrome-plated CG8M with alloy 6 notch, chrome-plated CF3M, and chrome-plated CF3M with alloy 6 notch, M35-1, or CK3MCuN
Seal	Fisher TCM	Fisher TCM Plus and Fisher TCM Ultra
	HD (Heavy-Duty) Metal	R30006 (alloy 6)
HD Seal Wave Spring		N07750
HD Seal Radial Seal		PTFE
High Temp HD Seal Piston Ring		Graphite FMS 17F39
Bearings		PEEK/PTFE <sup>(3)</sup> , 316L Nitride, alloy 6B, silver-plated alloy 6B, carbon-filled PTFE with N10276 sleeve, or glass-filled PTFE with N10276 sleeve
Thrust Washer (NPS 1, 1-1/2, and 2 only)		S31600 or N10276
Seal Retainer Gasket		Laminated graphite
Packing		PTFE V-ring with one carbon-filled PTFE conductive packing ring <sup>(4)</sup> , or ENVIRO-SEAL packing
Shafts		S20910, N10276, N05500, or S31254 <sup>(5)</sup>
Groove Pin (NPS 1 through 12 only)		S31600 (316 stainless steel)
Taper Key (NPS 1 through 12) or Pins (NPS 14 through 20)		(NPS 1 through 12) R30006, (NPS 14 through 20) S20910
Taper Pin (NPS 1, 1-1/2, and 2)		S20910
Pipe Plug (optional NPS 1 through 12)		S31700 (317 stainless steel) NPS 14, 16 and 20, S31600 (316 stainless steel) NPS 1 through 12)
Seal Retainer Screws and Clips		Stainless steel
Packing Follower and Packing Box Ring		CF8M (316 stainless steel) or S31254
Spacer and Bushing (NPS 3 through 12)		S31700
Packing Follower Bolting and Optional Line Bolting		Grade B7 or B7M steel studs, 2H, 2HM, or B8M nuts

1. Includes stress relief of body, seal protector ring or flow ring.  
 2. CF3M is available in all areas and is the standard material offering in Europe (not available for NPS 14 through 20).  
 3. PEEK (Poly-ether-ether-ketone) w/PTFE liner.  
 4. Carbon-filled PTFE ring is used for grounding.  
 5. S31254 shaft may cause the valve to be derated. Contact your Emerson Process Management sales office.

**Table 6. Maximum Allowable Inlet Pressure for CW2M and CG8M (317 Stainless Steel) Valves, CL150<sup>(1)</sup>**

TEMPERATURE	CW2M	CG8M	TEMPERATURE	CW2M	CG8M
°C	Bar		°F	Psig	Psig
-29 to 38	20.0	19.0	-20 to 100	290	275
93	17.9	16.2	200	260	235
149	15.9	14.8	300	230	215
204	13.8	13.4	400	200	195
232	12.8	12.6	450	185	183
260	---	11.7	500	---	170
316	---	9.6	600	---	140
343	---	8.6	650	---	125
371	---	7.6	700	---	110
399	---	6.5	750	---	95
427	---	5.5	800	---	80

1. These materials are not listed in ASME B16.34. The designation 150 is used only to indicate relative pressure-retaining capabilities and is not an ASME pressure-temperature rating class designation.

## Pressure Drops

Pressure drop limits of any given valve are based on valve body, and trim material limits. To find the appropriate pressure drop limitation, choose the desired valve size and temperature range. Then search table 7 for body limitations and table 8 for trim limitations. Information on limits for S31254, CW2M,

M35-1 and other alloy constructions can be obtained by contacting your Emerson Process Management sales office. The lowest number from the tables is the appropriate limit. **The tables for both trim and body limits must be consulted.**

**Table 7. Maximum Allowable Shutoff Pressure Drops (Body Ratings) based on Carbon Steel and Stainless Steel Valve Body Types. (The tables for both trim and body limits must be consulted.)**

TEMPERATURE RANGE	PRESSURE CLASS								
	WCC CL150	316L SST CL150	317 SST CL150	WCC CL300	316L SST CL300	317 SST CL300	WCC CL600	316L SST CL600	317 SST CL600
°C	Bar								
-46 to -29	---	15.9	19.0	---	41.4	49.6	---	82.7	99.3
-29 to 38	20.0	15.9	19.0	51.7	41.4	49.6	103	82.7	99.3
93	17.9	13.4	16.2	51.7	34.8	42.7	103	70.0	85.5
149	15.9	12.1	14.8	50.3	31.4	38.6	100	62.7	77.2
204	13.8	11.0	13.4	48.6	28.6	35.5	97.2	56.9	70.6
232	12.8	10.7	12.8	47.2	27.9	34.5	94.5	54.8	68.6
260	11.7	10.0	11.7	45.9	26.2	33.1	91.7	52.7	65.8
316	10.7	9.9	10.7	43.8	25.5	32.1	87.6	51.0	64.1
343	9.65	9.7	8.62	41.7	23.8	31.0	83.4	49.6	62.4
371	8.62	8.6	7.58	40.7	23.8	30.7	81.0	48.3	60.0
399	6.55	6.6	6.55	34.8	23.1	29.3	69.6	46.2	58.9
427	5.52	5.5	5.52	28.3	22.8	29.0	56.9	45.5	58.3
°F	Psi								
-50 to -20	---	230	275	---	600	720	---	1200	1440
-20 to 100	290	230	275	750	600	720	1500	1200	1440
200	260	195	235	750	505	620	1500	1015	1240
300	230	175	215	730	455	560	1455	910	1120
400	200	160	195	705	415	515	1410	825	1025
450	185	155	185	685	405	500	1370	795	995
500	170	145	170	665	380	480	1330	765	955
550	155	143	155	635	370	465	1270	740	930
600	140	140	140	605	360	450	1210	720	905
650	125	125	125	590	350	445	1175	700	890
700	110	110	110	570	345	430	1135	685	870
750	95	95	95	505	335	425	1010	670	855
800	80	80	80	410	330	420	825	660	845

**Table 8. Maximum Allowable Shutoff Pressure Drops based on Trim (Bearing and Seal).**  
(Note: Do not exceed the PN or ASME pressure/temperature rating of the valve or mating flanges.)

BEARING MATERIAL	BALL SEAL	TEMPERATURE RANGE, °C	VALVE SIZE, NPS												
			1	1-1/2	2	3	4	6	8	10	12	14	16	20	
			Bar												
PEEK/PTFE	Fisher TCM Plus or Ultra	-46 to 38	51.7	51.7	51.7	51.7	51.7	51.7	51.7	51.7	40.2	37.6	31.0	23.8	31.0
		93	37.9	37.9	37.9	37.9	37.9	37.9	37.9	37.9	37.9	37.6	31.0	23.8	31.0
		149	24.1	24.1	24.1	24.1	24.1	24.1	24.1	24.1	24.1	24.1	24.1	23.8	24.1
		204	10.3	10.3	10.3	10.3	10.3	10.3	10.3	10.3	10.3	10.3	10.3	10.3	10.3
	232	3.45	3.45	3.45	3.45	3.45	3.45	3.45	3.45	3.45	3.45	3.45	3.45	3.45	
	HD Metal <sup>(1)</sup>	-46 to 260	51.7	51.7	51.7	51.7	51.7	51.7	51.7	51.7	40.9	38.1	31.0	26.5	31.0
	Flat Metal <sup>(2)</sup>	-73 to 260	---	---	---	20.7	20.7	20.7	20.7	20.7	10.3	10.3	---	---	---
Flow Ring	260	103.4	103.4	103.4	103.4	72.4	75.2	73.8	40.5	37.7	40.5	35.0	44.7		
R30006	HD Metal <sup>(1)</sup>	-46 to 288	51.7	50.0	25.7	17.5	11.0	10.9	11.2	6.14	5.72	6.14	7.52	6.83	
	High Temp HD Metal <sup>(1)</sup>	228 to 427	38.3 <sup>(3)</sup>	37.5 <sup>(3)</sup>	19.3 <sup>(3)</sup>	13.2 <sup>(3)</sup>	8.3 <sup>(3)</sup>	8.2 <sup>(3)</sup>	8.4 <sup>(3)</sup>	4.6 <sup>(3)</sup>	4.3 <sup>(3)</sup>	---	---	---	
	Flat Metal <sup>(2)</sup>	-73 to 427	---	---	---	17.0	10.1	10.7	10.6	5.86	5.52	---	---	---	
	Flow Ring	427	74.5	49.6	26.8	18.8	10.9	11.2	11.1	6.07	5.65	6.07	7.31	6.69	
R30006 Silver Plated	HD Metal <sup>(1)</sup>	-46 to 288	51.7	51.7	51.7	35.0	22.1	21.8	22.5	12.3	11.4	12.3	13.2	13.7	
	High Temp HD Metal <sup>(1)</sup>	228 to 427	38.3 <sup>(3)</sup>	38.3 <sup>(3)</sup>	38.3 <sup>(3)</sup>	26.3 <sup>(3)</sup>	16.5 <sup>(3)</sup>	16.3 <sup>(3)</sup>	16.9 <sup>(3)</sup>	9.2 <sup>(3)</sup>	8.6 <sup>(3)</sup>	---	---	---	
	Flat Metal <sup>(2)</sup>	-73 to 427	---	---	---	20.7	20.1	20.7	20.7	10.3	10.3	---	---	---	
	Flow Ring	427	103.4	103.4	53.5	37.6	21.8	22.5	22.2	12.1	11.3	12.1	14.6	13.4	
S31600L Nitride	HD Metal <sup>(1)</sup>	-46 to 288	51.0	51.0	51.0	51.7	36.7	36.3	37.4	20.5	19.1	---	---	---	
	High Temp HD Metal <sup>(1)</sup>	228 to 427	---	---	---	38.3 <sup>(3)</sup>	27.6 <sup>(3)</sup>	27.2 <sup>(3)</sup>	28.1 <sup>(3)</sup>	15.4 <sup>(3)</sup>	14.3 <sup>(3)</sup>	---	---	---	
	Flat Metal <sup>(2)</sup>	-73 to 427	---	---	---	20.7	20.7	20.7	20.7	10.3	10.3	---	---	---	
	Flow Ring	427	99.3	99.3	88.9	62.7	36.3	37.4	37.0	20.2	18.8	---	---	---	
BEARING MATERIAL	BALL SEAL	TEMPERATURE RANGE, °F	Psi												
PEEK/PTFE	Fisher TCM Plus or Ultra	-50 to 100	750	750	750	750	750	750	750	583	545	450	345	450	
		200	550	550	550	550	550	550	550	550	545	450	345	450	
		300	350	350	350	350	350	350	350	350	350	350	345	350	
		400	150	150	150	150	150	150	150	150	150	150	150	150	
		450	50	50	50	50	50	50	50	50	50	50	50	50	
	HD Metal <sup>(1)</sup>	-50 to 500	750	750	750	750	750	750	750	593	553	450	384	450	
	Flat Metal <sup>(2)</sup>	-100 to 500	---	---	---	300	300	300	300	150	150	---	---	---	
Flow Ring	500	1500	1500	1500	1500	1050	1090	1070	587	547	587	508	648		
R30006	HD Metal <sup>(1)</sup>	-50 to 550	750	725	373	254	160	158	163	89	83	89	109	99	
	High Temp HD Metal <sup>(1)</sup>	550 to 800	555 <sup>(3)</sup>	544 <sup>(3)</sup>	280 <sup>(3)</sup>	191 <sup>(3)</sup>	120 <sup>(3)</sup>	119 <sup>(3)</sup>	122 <sup>(3)</sup>	67 <sup>(3)</sup>	62 <sup>(3)</sup>	---	---	---	
	Flat Metal <sup>(2)</sup>	-100 to 800	---	---	---	246	146	155	154	85	80	---	---	---	
	Flow Ring	800	1080	720	388	273	158	163	161	88	82	88	106	97	
R30006 Silver Plated	HD Metal <sup>(1)</sup>	-50 to 550	750	750	750	508	320	316	326	178	166	178	192	198	
	High Temp HD Metal <sup>(1)</sup>	550 to 800	555 <sup>(3)</sup>	555 <sup>(3)</sup>	555 <sup>(3)</sup>	381 <sup>(3)</sup>	240 <sup>(3)</sup>	237 <sup>(3)</sup>	245 <sup>(3)</sup>	134 <sup>(3)</sup>	125 <sup>(3)</sup>	---	---	---	
	Flat Metal <sup>(2)</sup>	-100 to 800	---	---	---	300	292	300	300	150	150	---	---	---	
	Flow Ring	800	1500	1500	776	546	316	326	322	176	164	176	212	194	
S31600L Nitride	HD Metal <sup>(1)</sup>	-50 to 550	740	740	740	750	533	527	543	297	277	---	---	---	
	High Temp HD Metal <sup>(1)</sup>	550 to 800	---	---	---	555 <sup>(3)</sup>	400 <sup>(3)</sup>	395 <sup>(3)</sup>	407 <sup>(3)</sup>	223 <sup>(3)</sup>	208 <sup>(3)</sup>	---	---	---	
	Flat Metal <sup>(2)</sup>	-100 to 800	---	---	---	300	300	300	300	150	150	---	---	---	
	Flow Ring	800	1440	1440	1290	910	527	543	537	293	273	---	---	---	

1. Pressure drops shown for HD metal seals are for forward flow only. For reverse flow with HD metal seal, limit pressure drop to 6.9 bar (100 psig).  
 2. Lubricated service only.  
 3. Consult your Emerson Process Management sales office if higher pressure drops are required.

Table 9. Fisher V150 Dimensions

VALVE SIZE	V150 DIMENSIONS (ISA S75.04) <sup>(1)</sup>										
	A	B	D	G	K	M <sup>(3)</sup>	N <sup>(3)</sup>	S Diameter	T	U	W
<b>DN</b>	<b>mm</b>										
25	102	56		83	95	79	73	13			
40	114	62	188	90	121	92	80	15.9 and 15.9 x 12.7	117	---	14.2
50	124	67		87	127	100	87	15.9 and 15.9 x 12.7			
80	165	79		100	130	106	100	19.1			14.2
100	194	101	214	133	141	119	100	19.1	152	31.8	14.2
150	229	109		151	164	127	114	25.4			17.5
200	243	124		184	232	133	127	31.8			
250	297	147	208	222	260	146	133	31.8	235	46.0	17.5
300	338	174		268	303	152	133	38.1			
<b>NPS</b>	<b>Inch</b>										
1	4.00	2.21		3.19	3.75	3.12	2.88	1/2			
1-1/2	4.50	2.46	7.38	3.38	4.75	3.62	3.12	5/8 and 5/8 x 1/2	4.62	---	0.56
2	4.88	2.63		4.19	5.00	3.94	3.44	5/8 and 5/8 x 1/2			
3	6.50	3.10		4.62	5.12	4.19	3.94	3/4			0.56
4	7.62	3.99	8.44	5.25	5.56	4.69	3.94	3/4	6.00	1.25	0.56
6	9.00	4.29		5.94	6.44	5.00	4.50	1			0.69
8	9.56	4.88		7.69	9.12	5.25	5.00	1-1/4			
10	11.69	5.77	8.19	8.75	10.25	5.75	5.25	1-1/4	9.25	1.81	0.69
12	13.31	6.87		10.56	11.94	6.00	5.25	1-1/2			
14 <sup>(2)</sup>	15.00	8.12		11.62	13.50	6.00	5.25	1-3/4	10.75	2.00	0.75
16 <sup>(2)</sup>	16.00	9.00	14.00	13.00	14.38	6.00	5.25	2-1/8	10.75	2.00	0.75
20	20.00	9.25		16.00	18.00	7.00	6.25	2-1/2	13.25	3.00	0.88

1. Inlet flange stud bolt length is longer than the standard length specified in ASME B16.5. See dimension M below.  
 2. NPS 14 and 16 valves are available in ASME B16.10 short, only. See dimension A for ASME B16.10 short shown in figure 8.  
 3. Clearance necessary to remove flange bolts.

Figure 5. Fisher V150 Dimensions (also see table 9)

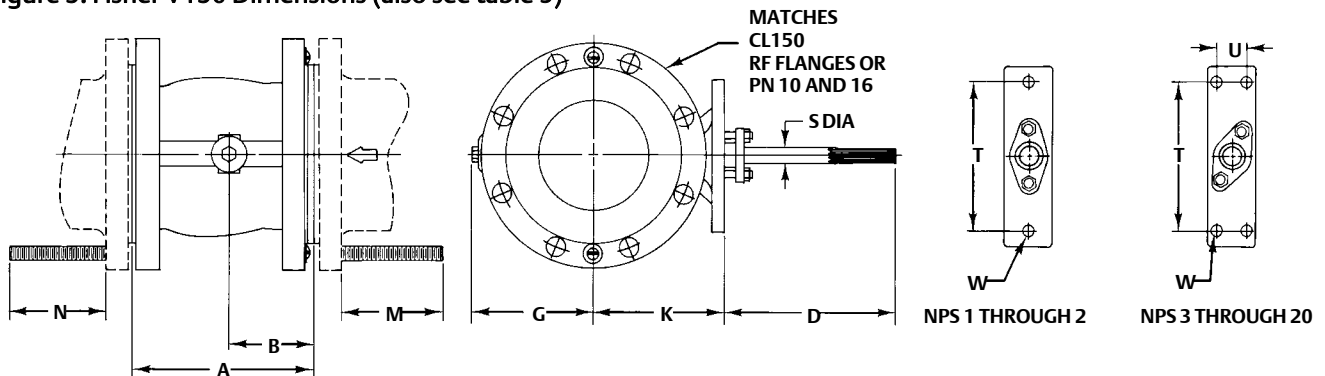

1182625-K  
82153-5

**Product Bulletin**

51.3:Vee-Ball  
May 2012

**Vee-Ball Valves**  
D101363X012

**Table 10. Fisher V200 Dimensions**

VALVE SIZE, NPS	V200 DIMENSIONS (ISA S75.04)														ASME B16.5 RF FLANGES
	A	B	D	G	K	M			R	R1	S	T	U	W	
						CL150	CL300	CL600							
<b>mm</b>															
1	102	56		81	95	176	202	202	51	102	12.7				
1-1/2	114	62	188	89	121	189	224	224	73	119	15.7 and 15.7 x 12.7	117	---	14.2	CL150, 300, and 600
2	124	67		106	127	211	236	236	92	137	15.7 and 15.7 x 12.7				
3	165	79		117	130	254	279	286	127	167	19.1				
4	194	101	214	133	141	286	305	343	157	197	19.1	152	32	14.2	CL150
6	229	109		159	164 <sup>(1)</sup>	343	362	413	216	260	25.4				
8	243	124		195	232	343	387	426	270	314					CL150
10	297	147	208	222	260	419	---	---	324	368	31.8	235	46	17.5	
<b>Inch</b>															
1	4.00	2.21		3.19	3.75	6.94	7.94	7.94	2	4.00	1/2				CL150 and 300
1-1/2	4.50	2.46	7.38	3.50	4.75	7.44	8.81	8.81	2.88	4.68	5/8 and 5/8 x 1/2	4.62	---	0.56	
2	4.88	2.63		4.19	5.00	8.31	9.31	9.31	3.63	5.38	5/8 and 5/8 x 1/2				
3	6.50	3.10		4.62	5.12	10.00	11.00	11.25	5.00	6.56	3/4				CL150
4	7.62	3.99	8.44	5.25	5.56	11.25	12.00	13.50	6.19	7.76	3/4	6.00	1.25	0.56	
6	9.00	4.29		6.25	6.44 <sup>(1)</sup>	13.50	14.25	16.25	8.50	10.24	1				
8	9.56	4.88		7.69	9.12	13.50	15.25	16.75	10.63	12.38					CL150
10	11.69	5.77	8.19	8.75	10.25	16.50	---	---	12.75	14.50	1-1/4	9.25	1.81	0.69	

1. 179 mm (7.06 inches) for NPS 6, CL600 valves only.

**Figure 6. Fisher V200 Dimensions (also see table 10)**

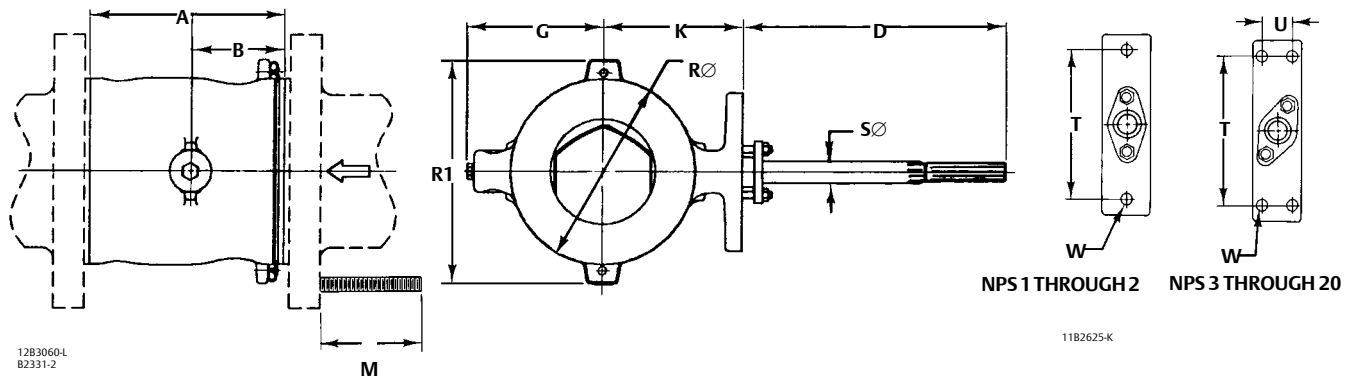
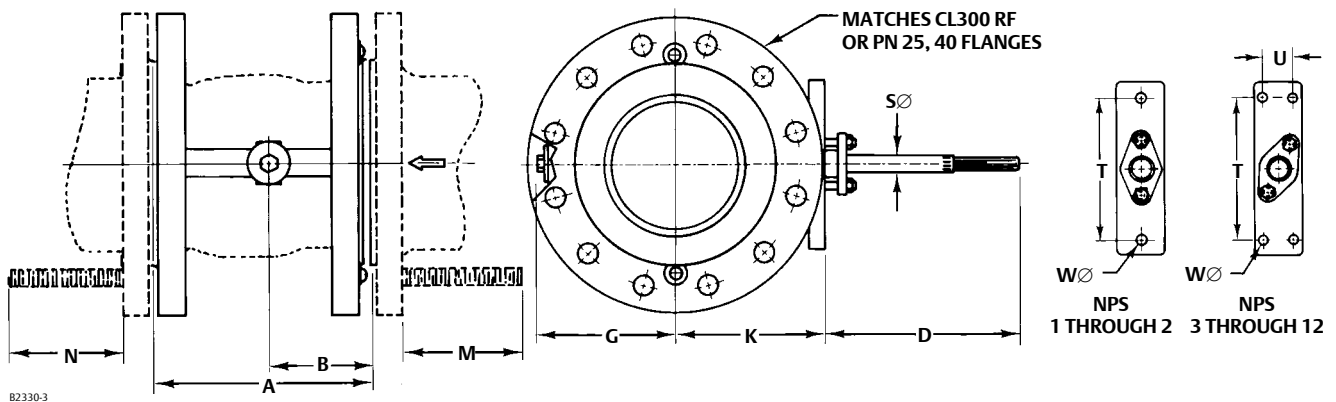

Table 11. Fisher V300 Dimensions

VALVE SIZE, DN <sup>(1)</sup>	V300 DIMENSIONS (ISA S75.04)										
	A	B	D	G	K	M <sup>(2)</sup>	N <sup>(2)</sup>	S Diameter	T	U	W
mm											
25	102	56		81	95	100	94	13			
40	114	62	188	89	121	114	108	16 and 16 X 13	117	---	14.2
50	124	67		106	127	106	100	16 and 16 X 13			
80	165	79		117	130	133	121	19			
100	194	101	214	133	141	140	127	19	152	32	17.5
150	229	109		159	164	152	140	25			
200	243	124		195	232	165	152	32			
250	297	147	208	222	260	186	173	32	235	46	19.5
300	338	174		268	303	198	186	38			
356 mm (14-in.)	381	206	356	295	343	197	178	44.5	273	50.8	
406 mm (16-in.)	406	228	356	338	356	210	191	53.8	273	50.8	19.5
Inch											
1	4.00	2.21		3.19	3.75	3.94	3.69	1/2			0.56
1-1/2	4.50	2.46	7.38	3.50	4.75	4.50	4.25	5/8 and 5/8 X 1/2	4.62	---	
2	4.88	2.63		4.19	5.00	4.19	3.94	5/8 and 5/8 X 1/2			
3	6.50	3.10		4.62	5.12	5.25	4.75	3/4			0.69
4	7.62	3.99	8.44	5.25	5.56	5.50	5.00	3/4	6.00	1.25	
6	9.00	4.29		6.25	6.44	6.00	5.50	1			
8	9.56	4.88		7.69	9.12	6.50	6.00	1-1/4			0.75
10	11.69	5.77	8.19	8.75	10.25	7.31	6.81	1-1/4	9.25	1.81	
12	13.31	6.87		10.56	11.94	7.81	7.31	1-1/2			
14	15.00	8.12	14.00	11.62	13.50	7.75	7.00	1-3/4	10.75	2.00	0.75
16	16.00	9.00	14.00	13.31	14.38	8.25	7.50	2-1/8			

1. DN25, 40, 50, 80, and 100 are the only sizes offered in V300 for Europe.  
2. Clearance necessary to remove flange bolts.

Figure 7. Fisher V300 Dimensions (also see table 11)



**Table 12. Fisher V150 Optional Dimensions**

V150 OPTIONAL DIMENSIONS FOR NPS 1 THROUGH 12 (ASME B16.10 SHORT)						
VALVE SIZE, NPS	A		M		N	
	mm	Inches	mm	Inches	mm	Inches
1	127	5.00	103	4.06	71	2.81
1-1/2	165	6.50	135	5.31	78	3.06
2	178	7.00	155	6.11	92	3.61
3	203	8.00	142	5.61	98	3.86
4	229	9.00	155	6.11	98	3.86
6	267	10.50	163	6.40	112	4.40
8	292	11.50	182	7.15	124	4.90
10	330	13.00	176	6.94	132	5.19
12	356	14.00	170	6.69	132	5.19

**Table 13. Fisher V200 Optional Dimensions**

V200 OPTIONAL DIMENSIONS (ASME B16.10 SHORT) <sup>(1,2)</sup>		
VALVE SIZE, NPS	A	M
<b>mm</b>		
1	127	202
1-1/2	165	240
2	178	268
3	203	286
4	229	321
6	267	381
8	292	394
10	330	451
<b>Inch</b>		
1	5.00	7.94
1-1/2	6.50	9.44
2	7.00	10.56
3	8.00	11.25
4	9.00	12.62
6	10.50	15.00
8	11.50	15.50
10	13.00	17.75

1. Available for CL150 valves only.  
2. ASME B16.10 short dimensions are actually longer than ISA S75.04 dimensions.

**Figure 8. Fisher V150 and V200 Optional Dimensions (also see tables 12 and 13)**

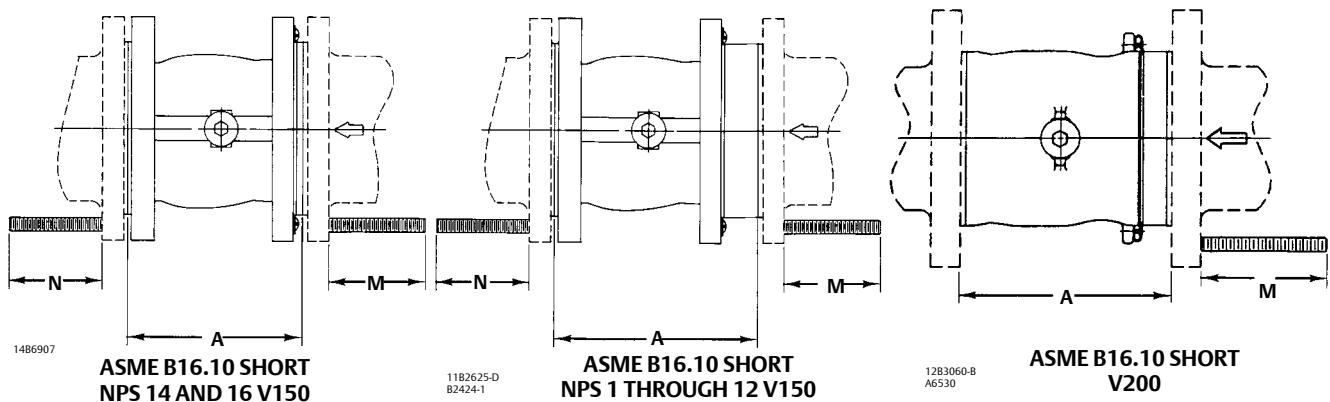

**NOTES:**

- NPS 1 THROUGH 12 VALVES ARE AVAILABLE WITH EITHER ISA S75.04 FACE-TO-FACE DIMENSIONS OR ASME B16.10 SHORT FACE-TO-FACE DIMENSIONS. NPS 1 THROUGH 12 VALVES WILL BE SUPPLIED IN ISA S75.04 UNLESS YOU SPECIFY OTHERWISE. NOTE THAT ASME B16.10 SHORT DIMENSIONS ARE ACTUALLY LONGER THAN ISA S75.04.
- NPS 14 AND 16 VALVES ARE AVAILABLE ONLY WITH ASME B16.10 SHORT FACE-TO-FACE DIMENSIONS.
- NPS 20 VALVES ARE AVAILABLE ONLY WITH A 508 MM (20-INCH) FACE-TO-FACE DIMENSION.
- M AND N DIMENSIONS SHOWN FOR V150 ARE CLEARANCE NECESSARY TO REMOVE FLANGE BOLTS.

**Neither Emerson, Emerson Process Management, nor any of their affiliated entities assumes responsibility for the selection, use or maintenance of any product. Responsibility for proper selection, use, and maintenance of any product remains solely with the purchaser and end user.**

Fisher, Vee-Ball, FIELDVUE, and ENVIRO-SEAL are marks owned by one of the companies in the Emerson Process Management business unit of Emerson Electric Co. Emerson Process Management, Emerson, and the Emerson logo are trademarks and service marks of Emerson Electric Co. All other marks are the property of their respective owners.

The contents of this publication are presented for informational purposes only, and while every effort has been made to ensure their accuracy, they are not to be construed as warranties or guarantees, express or implied, regarding the products or services described herein or their use or applicability. All sales are governed by our terms and conditions, which are available upon request. We reserve the right to modify or improve the designs or specifications of such products at any time without notice.

**Emerson Process Management**  
Marshalltown, Iowa 50158 USA  
Sorocaba, 18087 Brazil  
Chatham, Kent ME4 4QZ UK  
Dubai, United Arab Emirates  
Singapore 128461 Singapore

www.Fisher.com

