

**I/A Series® Intelligent Vortex Flowmeter
Models 84F-T, 84F-U, 84W-T, and 84W-U
With HART Communication**

Installation, Operation, and Maintenance

Contents

Figures.....	vii
Tables.....	ix
1. Introduction	1
Overview	1
Reference Documents	1
Standard Specifications	1
Electrical Safety Specifications	6
Configurable Parameters	8
2. Installation	11
Fundamental Installation Requirements	11
Unpacking	11
Flowmeter Identification	11
Mechanical Installation	12
Dimensions	12
Hydrostatic Piping Testing	12
Piping Considerations	13
Effects of Piping on Flowmeter Performance	13
Liquid Installations	14
Gas Installations	15
Steam Installations	15
Saturated Steam	16
Superheated Steam	16
Insulation	16
Vibration	17
Ambient Temperature Limitations / Considerations	17
Meter Servicing	19
Location of Pressure and Temperature Taps	20
Mechanically Installing the Flowmeter Body	20
84F – Flanged Body	21
84W – Wafer Body	21
Mounting the Remote Electronics Housing	23
Cover Locks	24
Positioning the Display	24
Setting the Write Protect Jumper	25
Positioning the Housing	25
Electrical Installation	25
Integrally Mounted Electronics	26

Remotely Mounted Electronics	26
Preparing the Remote Signal Cable	26
Connecting the Remote Signal Cable	28
Installation with Conduit	28
Explosionproof / Flameproof Certifications	28
Field Termination Wiring	29
Conduit / Cable Gland Connections	29
Accessing Flowmeter Field Terminals	29
Wiring the Flowmeter to a Control Loop	30
Multidrop Communication	33
Wiring a Flowmeter With a Pulse Output	33
3. Operation Via Local Display	37
Local Keypad/Display	37
Display Bar Indicator	38
Password	38
Entering the Password	38
Activating an Edit, Pick-List, or User Menu Block	39
Editing Numbers and Strings	39
Signed Numbers	39
Unsigned Numbers	39
Strings	39
Picking from a List	39
Configuration Database	40
Using the Menu Tree	41
Moving Inside the Menu System	41
Top Level Menu	41
Measure Mode	44
Totals Mode	44
Status Mode	44
View Mode	46
Setup Mode	46
Setting Fluid Parameters	47
Setting Flow Parameters	47
Setting Tuning Parameters	48
Setting Totals Parameters	48
Setting Output Parameters	48
Setting Piping Parameters	49
Setting Tag Parameters	51
Setting Flowtube Parameters	51
Changing the Password	52
Setup Menu Tree	53
Calibration/Test Mode	55
Calibration	56
Test	56
Error Messages	58
Operation Error Messages	58

Configuration Error Messages	58
4. Operation Via HART Communicator	61
Online Menu	61
Explanation of Parameters	65
5. Troubleshooting	71
Flowmeter Output Indicates Flow When There Is No Flow	71
Flowmeter Has No Output (No mA Output and the Display [If So Equipped] Is Blank) ..	72
Flowmeter Has No Output With Flow, But Has a 4 mA Signal and a Lighted Display (If So Equipped).	72
Flowmeter Output Increases With Flow, However When It Approaches Full Scale, the Output Suddenly Goes To 4 mA.	73
Flowmeter with Remote Mounted Electronics Has No Output or Low Output With Flowing Conditions	73
Electronics Module Test	74
Flowmeter Has Incorrect Output	75
6. Maintenance.....	77
Introduction	77
Vortex Generation and Shedding	77
Vortex Sensing	77
Electronic Module	78
Electronic Module Removal	78
Electronic Module Replacement	79
Neck Board Replacement	80
Removal Procedure	81
Installation Procedure	82
Pre-amplifier Replacement	83
Removal Procedure	83
Installation Procedure	84
Post-Assembly Dielectric Test	85
Sensor Replacement	85
Integrally Mounted Flowmeter	85
Sensor Assembly Removal	86
Sensor Assembly Installation	86
Remotely Mounted Flowmeter	89
Sensor Assembly Removal	89
Sensor Assembly Installation	89
Appendix A. Isolation Valves.....	93
Replacing the Sensor	93
Replacing or Installing an Isolation Valve	94
Index	97

Figures

1	Pressure -Temperature Limits with ANSI Flanges	4
2	Pressure -Temperature Limits with Metric Flanges	4
3	Pressure -Temperature Limits with Isolation Valves	5
4	Sample Flowmeter Data Plate	12
5	Piping Arrangements	14
6	Piping for Gas Applications	15
7	Piping for Saturated Steam Applications	16
8	Insulation	16
9	Sensor Mounting to Minimize Effect of Vibration	17
10	Typical Piping Configuration	19
11	Pressure and Temperature Tap Locations	20
12	84F Flowmeter Installation	21
13	84W Flowmeter Centering (using Spacers)	23
14	Mounting the Remote Electronics Housing	24
15	Cover Locks	24
16	Write Protect Jumper	25
17	Connection of Remote Signal Cable (Junction Box End)	28
18	Accessing Field Terminals	29
19	Identification of Field Terminals	30
20	Supply Voltage and Loop Load	31
21	Loop Wiring 4 to 20 mA Output Flowmeters	32
22	Typical Multidrop Network	33
23	Wiring an 84F-T or 84W-T Flowmeter with a Pulse Output Transistor Switch (sinking) Counter Input with Receiver Supplied Power	34
24	Wiring an 84F-T or 84W-T Flowmeter with a Pulse Output Transistor Switch (sinking) Counter Input with External Power Supply and Pull-Up Resistor	35
25	Wiring an 84F-T or 84W-T Flowmeter with a Pulse Output Transistor Switch (sourcing) Counter Input with External Power Supply and Pull-Up Resistor	36
26	Local Display	37
27	Top Level Modes and Their Basic Functions	43
28	Status Mode Structure Diagram	45
29	View Mode Structure Diagram	46
30	Piping Configurations	51
31	Setup Menu Tree (1 of 3)	53
32	Setup Menu Tree (2 of 3)	54
33	Setup Menu Tree (3 of 3)	55
34	Calibration/Test Menu Tree	57
35	84 Vortex Flowmeter Online Menu Tree (1 of 4)	61
36	84 Vortex Flowmeter Online Menu Tree (2 of 4)	62
37	84 Vortex Flowmeter Online Menu Tree (3 of 4)	63
38	84 Vortex Flowmeter Online Menu Tree (4 of 4)	64

39	Electronic Module Connections	79
40	Display Connection	80
41	Preamplifier Assembly - Integrally Mounted	82
42	Preamplifier Assembly - Remotely Mounted	84
43	Connections for Post-Assembly Dielectric Test	85
44	Sensor Replacement - Integrally Mounted Flowmeter	87
45	Connector Bolt Torquing Sequence	88
46	Sensor Replacement - Remotely Mounted Flowmeter	91
47	Connector Bolt Torquing Sequence	94
48	Isolation Valve	95
49	Dual Manifold	96

Tables

1	Reference Documents	1
2	Nominal Flow Velocity Limits	2
3	Electrical Safety Specifications	6
4	Configurable Parameters	8
5	Mounting Arrangements	18
6	Preparation of Remote Signal Cable (Junction Box End)	26
7	Operation of Function Keys	38
8	Default Database When User Information Not Supplied	40
9	Default Database for Liquid	40
10	Default Database for Gas	40
11	Default Database for Steam	41
12	Operation Error Messages	58
13	Configuration Error Messages	58
14	Electronic Module Terminal Block Connections	78
15	Maximum Test Pressure	89

1. Introduction

Overview

The 84F-T, 84F-U, 84W-T, and 84W-U Vortex Flowmeters measure fluid (liquid, gas, or steam) flow rates using the principle of vortex shedding. The flowmeters produce a digital signal (HART protocol) and a 4-20 mA analog signal. The 84F-T and 84W-T also produce a pulse signal proportional to the volumetric flow rate.

Fluid flowing through the flowmeter body passes a specially shaped vortex shedder that causes vortices to form and shed alternately from the sides of the shedder at a rate proportional to the flow rate of the fluid. These shedding vortices create an alternating differential pressure that is sensed by a detector located above the shedder. A pulsed voltage is generated by the detector with a frequency that is synchronous with the vortex shedding frequency. This signal is then conditioned by an Electronic Module and processed by the microcontroller to produce a digital signal, an analog (4-20 mA dc) signal, and (in the 84F-T and 84W-T) a pulse signal.

The flowmeter allows direct analog connection to common receivers while still providing full digital communications using a HART Communicator or a PC-Based configurator.

Reference Documents

In addition to this instruction, there is other user documentation supporting the 84F-T, 84F-U, 84W-T, and 83W-U Vortex Flowmeters, as listed below.

Table 1. Reference Documents

Document Number	Document Description
Dimensional Prints	
DP 019-120	84F Flanged Body — Single Measurement Configuration
DP 019-121	84F Flanged Body — Dual Measurement Configuration
DP 019-122	84W Wafer Body
Parts Lists	
PL 008-714	84F Flanged and 84W Wafer Body Flowmeters
Technical Information and Instructions	
B0800AB	Ensuring Premium Performance with Foxboro Vortex Flowmeters
MI 019-177	84 Vortex Flowmeter FM and CSA Connection Diagrams
MI 019-179	Flow Products Safety Information ^(a)

(a) Available in many languages on line at www.foxboro.com/instrumentation/tools/safety/flow

Standard Specifications

Process Temperature Limits:

Standard Temp/Fluorolube Fill: -20 and +90°C (0 and 200°F)

Standard Temp/Silicone Fill: –20 and +200°C (0 and 400°F)

High Temp/Unfilled: 200 and 430°C (400 and 800°F)

Ambient Temperature Limits:

With Indicator: –20 and +80°C (0 and +176°F)

Without Indicator: –40 and +80°C (–40 and +176°F)

Power Supply Requirements:

Supply Voltage Limits: 15.5 and 42 V dc

Supply Current:

Digital Mode: 10 mA dc nominal

Analog Mode: 22 mA dc maximum

Reynolds Number Requirements

Rd = 5000 minimum; Automatic compensation for the nonlinear behavior of vortex shedding in the Rd range 5000 to 20,000 is built into the flowmeter. This compensation requires the user to input values for the flowing density and viscosity. Best accuracy is achieved at higher Reynolds numbers (>30,000 Rd).

Nominal Flow Velocity Limits: Can be calculated per Table 2.

Table 2. Nominal Flow Velocity Limits

Range Limit	Std. Temp. Range		High Temp. Range	
	m/s	ft/s	m/s	ft/s
Lower	$3.0/\sqrt{\rho_f}$	$2.5/\sqrt{\rho_f}$	$6.0/\sqrt{\rho_f}$	$5.0/\sqrt{\rho_f}$
Upper	$300/\sqrt{\rho_f}$	$250/\sqrt{\rho_f}$	$300/\sqrt{\rho_f}$	$250/\sqrt{\rho_f}$

— NOTE

The calculations in Table 2 apply for many applications but as they only provide nominal limits, Foxboro recommends using the FlowExpert Pro™ sizing program for your specific application.

Static Pressure Limits:

Minimum: Pressure sufficient to prevent flashing and meet the pressure drop requirements to attain maximum flow rate. Refer to the FlowExpertPro sizing program.

Maximum: Determined by flange rating.

Flowmeter Output:

Analog: 4 to 20 mA dc into a maximum 1350 ohm load depending on power supply (see Figure 20).

Digital (HART): Digital signal conveyed at 1200 Baud transmission rates via FSK tones superimposed on power supply leads.

Pulse Output (84F-T and 84W-T only): Isolated 2 wire transistor switch.

Pulse rate (0 to 10, 100, or 1000 Hz) proportional to volumetric flow rate or total flow.

— NOTE

Accuracy of 0 to 10 Hz pulse rate is $\pm 0.1\%$ from 3 to 10 Hz and $\pm 0.3\%$ from 0 to 3 Hz.

Pulse Output Specifications

Isolated 2-wire transistor switch

Applied voltage: 5 to 30 V dc

Maximum 'ON' state voltage drop: 1.0 V dc

Maximum 'ON' state current: 20 mA dc

Reverse polarity protected

Short Circuit protected

Connectable to pull-up and pull-down counters

Maximum Working Pressure:

84F Flanged Body Flowmeters

The maximum working pressure (MWP) of the flowtube at 100°F is shown on the data label.

The MWP at other temperatures for the 84F Flanged Body Flowmeter without isolation valve is given in Figure 1 and Figure 2. The nominal line size, body and flange material, and flange rating required to use these figures is found within the model number on the data label as follows:

84F-D02S2SDTJK

NO ISOLATION VALVE (S or D)
 FLANGE RATING CODE
 BODY AND FLANGE MATERIAL
 NOMINAL LINE SIZE

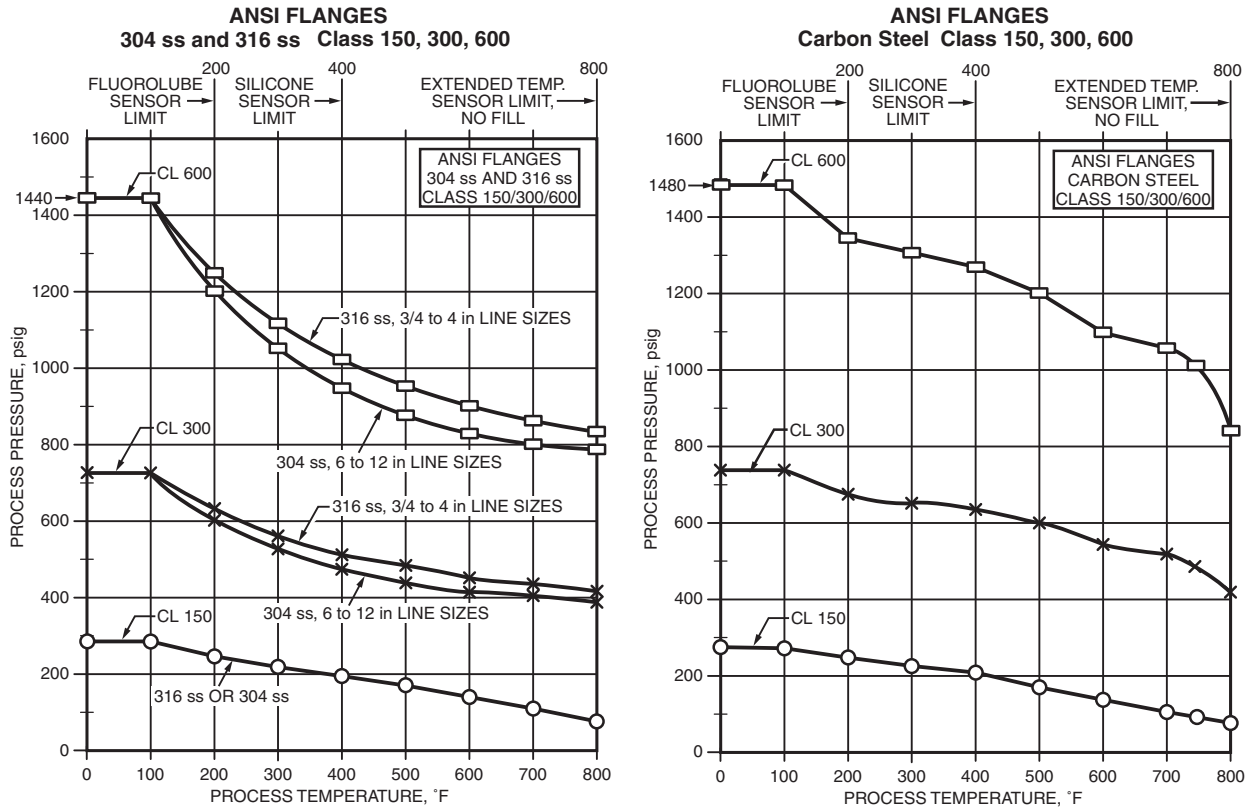

Figure 1. Pressure -Temperature Limits with ANSI Flanges

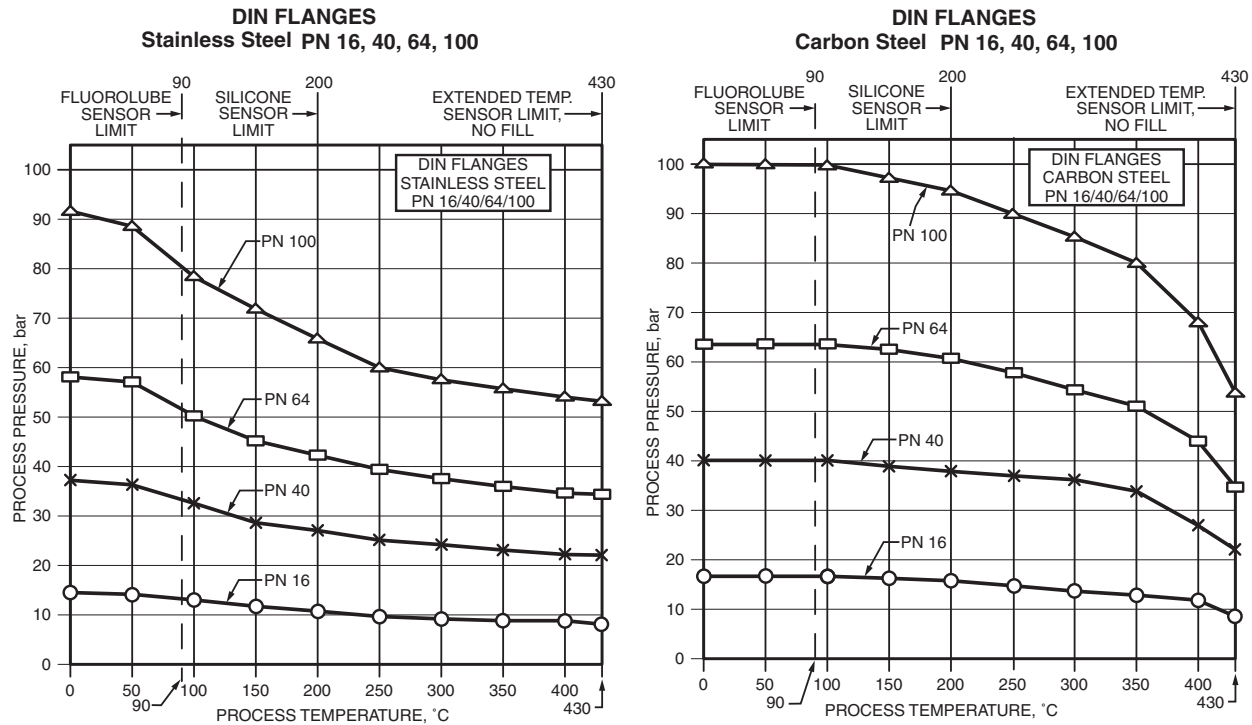

Figure 2. Pressure -Temperature Limits with Metric Flanges

84W Wafer Body Flowmeters

The maximum working pressure (MWP) of the flowtube at 100°F is shown on the data label. The flowmeters are designed to withstand pressure within carbon steel ANSI Class 600 and PN 100 flange ratings. The flowmeters have been designed to withstand the full pressure rating for carbon steel flanges.

Isolation Valves

Flowmeters equipped with an isolation valve have a maximum pressure rating of 1440 psi at 100°F (99 bar at 38°C). Isolation valves used with standard temperature range and with extended temperature range flowmeters are further limited to values shown in Figure 3. The nominal line size, sensor fill, and temperature range of your flowmeter is found within the model number on the data label as follows:

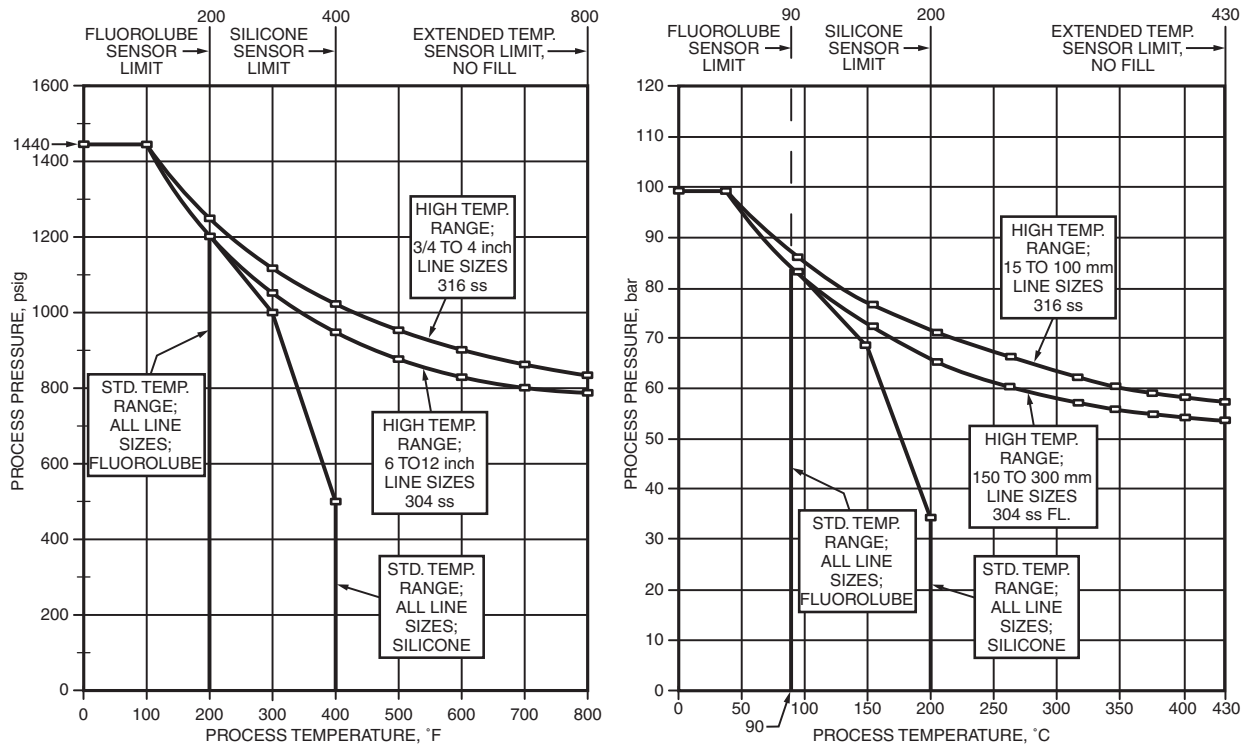
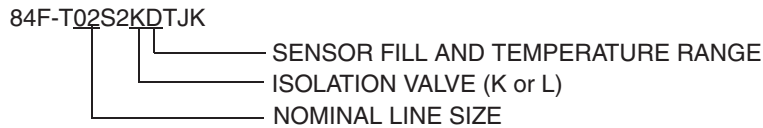

Figure 3. Pressure -Temperature Limits with Isolation Valves

Electrical Safety Specifications

— NOTE —

1. These flowmeters have been designed to meet the electrical safety descriptions listed in Table 3. For detailed information or status of testing laboratory approvals/certifications, contact Invensys Foxboro.
 2. See MI 019-179 for additional ATEX and IECEx safety information.
 3. With intrinsically safe approvals and certifications with a 24 V dc supply, an active barrier is required.
-

Table 3. Electrical Safety Specifications

Agency Certification, Types of Protection, and Area Classification	Application Conditions	Electrical Safety Design Code
ATEX intrinsically safe: II 1 GD EEx ia IIC	Sira 06ATEX2067X Integrally mounted or remote mounted (electronics and junction box). Temperature Class T4, T103°C, Ta = -40 to +80°C.	E
ATEX flameproof: II 2/1 (1) GD EEx d [ia] ia	Sira 06ATEX2067X Integrally mounted electronics. Temperature Class T4, T85°C, Ta = -20 to +80°C.	H
ATEX flameproof: II 2 (1) GD EEx d [ia]	Sira 06ATEX2067X Electronics housing of remote mounted version. Temperature Class T4, T85°C, Ta = -20 to +80°C.	
ATEX flameproof: II 1 GD EEx ia IIC.	Sira 06ATEX2067X Flowtube junction box of remote mounted version Temperature Class T4, T103°C, Ta = -40 to +80°C.	
FM intrinsically safe for Class I, II, III, Division 1, Groups A, B, C, D, E, F, G. Also, Class I, Zone 0, AEx ia IIC.	Connect per MI 019-177. Temperature Class T4; Ta = 80°C	F
FM explosionproof with IS sensor connection for Class I, Division 1, Groups B, C, and D; dust-ignitionproof for Class II, Division 1, Groups E, F, and G; Class III, Division 1.	Connect per MI 019-177. Temperature Class T5. Ta = 85°C	G
FM nonincendive for Class I, Division 2, Groups A, B, C, and D; Class II, Division 2, Groups F and G; Class III, Division 2.	Connect per MI 019-177. Temperature Class T4. T=80°C	K
CSA intrinsically safe for Class I, II, III, Division 1, Groups A, B, C, D, E, F, G. Also, Class I, Zone 0, Ex ia IIC.	Temperature Class T4; Ta = 80°C	C

Table 3. Electrical Safety Specifications (Continued)

Agency Certification, Types of Protection, and Area Classification	Application Conditions	Electrical Safety Design Code
CSA explosionproof with IS sensor connection for Class I, Division 1, Groups B, C, and D; dust-ignitionproof for Class II, Division 1, Groups E, F, and G; Class III, Division 1.	Temperature Class T5. Ta = 85°C	D
CSA nonincendive for Class I, Division 2, Groups A, B, C, and D; Class II, Division 2, Groups F and G; Class III, Division 2.	Temperature Class T4. T=80°C	M
IECEX intrinsically safe Ex ia IIC Dust-ignitionproof Ex tD A20 IP66	IECEX SIR 06.0020X Integrally mounted or remote mounted (electronics and junction box). Temperature Class T4, T103°C Ta = -40 to +80°C.	L
IECEX flameproof: Ex d [ia] ia IIC Dust-ignitionproof Ex tD A20 IP66	IECEX SIR 06.0020X Integrally mounted electronics. Temperature Class T4, T85°C, Ta = -20 to +80°C.	B
IECEX flameproof: Ex d [ia] Dust-ignitionproof Ex tD A20 IP66	IECEX SIR 06.0020X Electronic housing of remote mounted version. Temperature Class T4, T85°C Ta = -20 to +80°C.	
IECEX flameproof: Ex ia IIC Dust-ignitionproof Ex tD A20 IP66	IECEX SIR 06.0020X Flowtube junction box of remote mounted version Temperature Class T4, T103°C Ta = -40 to +80°C.	
Unit with CE mark and PED controls and records.		Y
Unit does not have CE mark; not to be installed in European Union (EU) countries.		Z

Configurable Parameters

Table 4 lists all of the configurable parameters and the factory default for the 84 Vortex Flowmeter.

Table 4. Configurable Parameters

Parameter	Parameter Name	Capability	Factory Default	Configurable with		
				Integral Indicator	HART Comm.	PC-Based Config.
Fluid	2 Fluid					
Fluid Type	3 New	Gas, Liquid, Steam	Liquid	Yes	Yes	
Fluid Name	3 Name		Water	Yes	Yes	
Temperature Unit	3 TmpEGU	degK, degF, degC, degR	deg F	Yes	Yes	
Flow Temperature	3 FlwTmp		70	Yes	Yes	
Density Unit	3 DenEGU	Pick list of density units	lb/ft ³	Yes	Yes	
Flow Density	3 FlwDen		62.315	Yes	Yes	
Base Density	3 BasDen		62.378	Yes	Yes	
Viscosity Unit	3 VisEGU	cPoise or cStoke	cP	Yes	Yes	
Viscosity	3 Visc		0.98	Yes	Yes	
Flow	2 Flow					
Flow Type	3 FlwMap	VolFlow, BVolFlow, MassFlow	VolFlow	Yes	Yes	
Flow Units	3 FlwEGU	Picklist	gal/m	Yes	Yes	
Flow Upper Range Value	3 FlwURV		232.73	Yes	Yes	
Flow Damping Factor	3 FlwDmp	Pick list of 8 choices from 0 to 32 s	2	Yes	Yes	
Flow Velocity Unit	3 VelEGU	Picklist	ft/s	Yes	No	
Tuning	2 Tuning					
Signal Conditioning	3 AddDrop	On or Off	On	Yes	Yes	
Reynolds Number Correction	3 ReyCor	On or Off	Off	Yes	Yes	
Low Flow Cut-In Level	3 LFCI	1 through 8	4	Yes	Yes	
Total	2 Total					
Net Total	3 TotNet					
Map	4 Map	Volume, Mass, BVolume	Volume	Yes	Yes	
EGU	4 EGU	Pick list dependent on Mapping	m ³	Yes	Yes	
Grand Total	3 TotGrd					
Map	4 Map	Volume, Mass, BVolume	Volume	Yes	Yes	

Table 4. Configurable Parameters

Parameter	Parameter Name	Capability	Factory Default	Configurable with		
				Integral Indicator	HART Comm.	PC-Based Config.
EGU	4 EGU	Pick list dependent on Mapping	m ³	Yes	Yes	
Output	2 Output					
Coms	3 Coms					
Poll Address	4PolAdr	0 through 15	0	Yes	Yes	
Preambles	4Preambl	2 to 20	5	Yes	Yes	
Fail	3 Fail	Downscale or Upscale	Down-scale	Yes	Yes	
Pulse	3 Pulse					
Pulse	4 Pulse	Raw, Rate, Total	Rate	Yes	Yes	
(If Raw)	Pul=Raw			Yes	Yes	
(If Rate)						
Upper Freq End Point	4 Freq	10, 100, 1000	1000	Yes	Yes	
(If Total)						
Pulse Width	4 Pwidth		50 ms	Yes	Yes	
Units	4 EGU		ft ³	Yes	Yes	
Units per Pulse	4 U/Pulse		1	Yes	Yes	
Display	3 Display					
Show	4 Show	FlwVol, TotNet, TotGrd (measurements to be displayed and their format)	FlwVol	Yes	Yes	
First Measurement	Show1st	FlwVol, Velcty, FlwBVo, FlwMas, Raw	FlwVol	Yes	Yes	
Cycle	4 Cycle	Automatic or Manual	Auto	Yes	Yes	
Pipe	2 Pipe					
Piping	3 Piping					
Configuration	4 Config	Picklist of 8 configurations	Straight	Yes	Yes	
Upstream Distance	4 UpDist	(in pipe diameters)	0	Yes	Yes	
Bore Size	3 BorSch	Picklist of 8 choices	Sched 40	Yes	Yes	
Tags	2 Tags					
HART Description	3 HrtDes	(16 characters maximum)	HART Description	Yes	Yes	
HART Tag	3 HrtTag	(8 characters maximum)	HART Tag	Yes	Yes	
HART Message		32 characters maximum	HART Message	No	Yes	

Table 4. Configurable Parameters

Parameter	Parameter Name	Capability	Factory Default	Configurable with		
				Integral Indicator	HART Comm.	PC-Based Config.
Flowtube	2NewTube					
Model Number	3 Model	(16 characters maximum)	84F-T02 S1SSTJF	Yes	Yes	
Custom Design	3 Special					
Flowtube Diameter	4 TubDia	Flowtube diameter in meters	0.0491998	Yes	Yes	
Coef of Expansion	4 TubAlp	(in m/m/°K)	1.7262e ⁻⁵	Yes	Yes	
LFCI User Factor	4 LfUFac		1.0	Yes	Yes	
Reference Number	3 Ref No	(16 characters maximum)	123456789 abcdefg	Yes	Yes	
K-Reference	3 K Ref					
K-Factor Unit	4 K EGU	p/l, p/ft ³	p/ft ³	Yes	Yes	
Reference K-Factor	4 K Ref	(from flowmeter tag)	258	Yes	Yes	
Password	2 Passwd					
Password to reset Net and Pulse Totalizer	3 LoPwd	(4 characters)	(4 spaces)	Yes	No	
Password for all functions	3 HiPwd	(4 characters)	(4 spaces)	Yes	No	

2. Installation

Fundamental Installation Requirements

These flowmeters must be installed by trained personnel to meet all applicable local installation regulations, such as hazardous location requirements, electrical wiring codes, and mechanical piping codes.

This chapter outlines recommendations that provide the highest level of flowmeter performance for your process.

Unpacking

Your 84 Series Vortex Flowmeter is built to be durable, but it is part of a calibrated precision system and should be handled as such.

— NOTE —

84W Flowmeters may (depending on pressure rating of flanges with which they are used) have a set of centering spacers included. Do **not** discard these centering spacers. They must be used to install the flowmeter properly.

Flowmeters with remote-mounted electronics have a cable connecting the flowmeter junction box and electronics housing. Do **not** allow the weight of either the flowmeter body or electronics housing to be supported by the remote cable.

Remove the flowmeter body from the shipping carton using care to avoid dropping or otherwise subjecting it to impact, particularly at the flange or wafer faces. Never put anything through the flowmeter body for lifting purposes as damage to the shedder bar may occur.

After removing the flowmeter body from its shipping carton, inspect it for visible damage. If any damage is observed, notify the carrier immediately and request an inspection report. Obtain a signed copy of the report from the carrier. The calibration certificate and any other documentation shipped with the meter should be separated from the packing material and held for future reference. Re-install any flange covers or protective material to safeguard the meter until it is installed.

Packing material should be disposed of in accordance with local regulations. All packing material is nonhazardous and is generally acceptable to landfills.

Flowmeter Identification

Before installing your flowmeter, check its data plate to assure that it is correct for your application. Specifications such as maximum ambient temperature, process temperature, and working pressure are given on the data plate. The model code is also stamped on the data plate as shown in Figure 4 and is digitally readable from the configuration menu. For interpretation of the Model Code, refer to PL 008-714.

Electrical certification information is located on the right end of the data plate.

The software version of your device can be found in View mode as **2 SW Rev.**

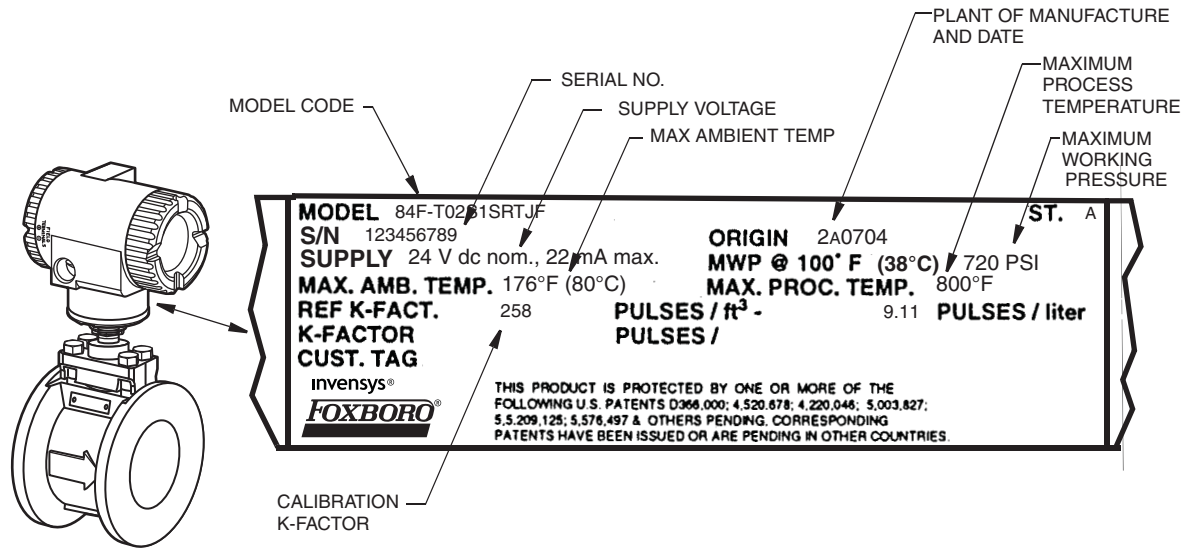

Figure 4. Sample Flowmeter Data Plate

Mechanical Installation

Both the flanged and wafer body flowmeters are offered in two mounting arrangements: (1) integral, and (2) remote (electronics housing separate from the flowmeter body). The following sections deal with both the integrally and remotely mounted electronics flowmeter arrangements. The installation guidelines given below are also summarized for your convenience in B0800AB, *Ensuring Premium Performance with Foxboro Intelligent Vortex Flowmeters*.

Dimensions

For overall dimensions of the flowmeter, refer to the appropriate dimensional print listed in “Reference Documents” on page 1.

Hydrostatic Piping Testing

The 84F Series Vortex Flowmeter is designed to meet the pressure limits of the flange rating specified in the model code.

84F-****x
└── END CONNECTON AND FLANGE RATING

If your flowmeter is being installed in an application where hydrostatic testing will be preformed, do **not** remove the sensor from the flowmeter.

Piping Considerations

Effects of Piping on Flowmeter Performance

Flanges

The flange of the adjoining pipe must be the same nominal size and pressure rating as the flowmeter. Flanges with a smooth bore, similar to weld neck flanges, are preferred.

Mating Pipe

Your flowmeter was calibrated at the factory with Schedule 40 piping upstream and downstream of the meter. If your application does not have Schedule 40 pipe, enter the appropriate pipe size during configuration. This assures that the calibration factor and flowmeter accuracy are maintained.

Upstream and Downstream Disturbances

The flowmeter should normally be mounted in a straight, unobstructed pipe with a minimum of 30 pipe diameters upstream of the meter and five pipe diameters downstream. For those installations where this upstream requirement is not met, the type of disturbance must be selected from a picklist during configuration and the distance to the disturbance in pipe diameters entered. This assures that the flowmeter accuracy is maintained.

Piping Alignment

The bore of the pipe (flange) and flowmeter must be aligned (see “Mechanically Installing the Flowmeter Body” on page 20), and the flange gaskets installed such that they do not protrude into the flow stream.

If the adjoining piping cannot be properly aligned, it is preferable to make the best possible alignment with the upstream flange. This minimizes the flow disturbance in the flowmeter.

— NOTE

1. Flowmeters mounted near pump discharge or suction lines may be exposed to oscillatory flow that may affect vortex shedding or product pipe vibration. Also, flowmeters mounted near the discharge of a liquid positive displacement pump or near oscillating control valves may experience severe flow fluctuations that could damage the sensor. To avoid these adverse situations, install the meter at least 20 feet or 40 pipe diameters, whichever is larger, from the disturbance in question.
 2. Good piping practice requires that the internal surface of the pipe shall be free from mill scale, pits, holes, reaming scores, rifling, bumps, or other irregularities for at least four pipe diameters upstream and two pipe diameters downstream of the meter.
-

Process Temperature

Your flowmeter was calibrated at 75°F (24°C). If your process temperature is different, enter the appropriate process operating temperature during configuration. Your flowmeter automatically adjusts the calibration factor to account for thermal expansion of the metals due to process temperatures that are different than the reference calibration temperature.

Pipe Position

Piping should be planned to maintain full pipe conditions at the flowmeter. When flow is moving with gravity, elevate the downstream pipe length above the meter installation level to maintain a full pipeline.

Mounting Position

For optimal performance, the mounting locations of the sensor and integral electronics relative to the piping must be considered. Factors that influence this decision include process fluid type, ambient temperature, and vibration. Mount the meter in accordance with the installation guidelines for various process fluids described below. Also see Table 5.

Liquid Installations

For liquid flow installations, it is recommended that the meter be mounted upstream at least 5 pipe diameters from the control valve. In vertical installations, the meter should be mounted in the upward flowing leg. This helps to maintain a full pipe and ensures that there is sufficient back pressure to prevent flashing or cavitation.

For liquid installations with occasional gas pockets or bubble formation, install piping as recommended in Figure 5 so as to not trap the gas pockets or bubbles inside the flowmeter.

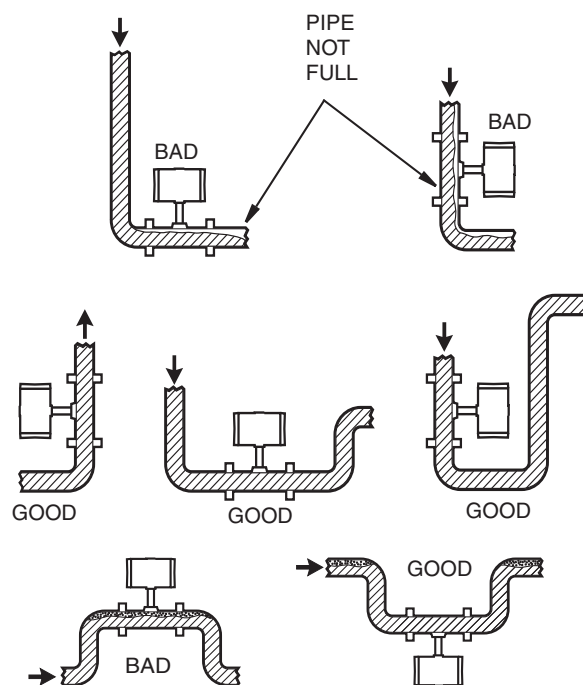

Figure 5. Piping Arrangements

For a clean liquid, the electronics housing can be mounted above or below the flowmeter body. Care should be taken so that entrapped air does not accumulate in the sensor cavity. A meter used on liquid should be mounted upstream from a control valve. Flowmeters can also be mounted with the electronics housing positioned to the side. This ensures escape of entrapped air.

Gas Installations

For gas flow installations, several choices for flowmeter location should be considered. For maximum rangeability, locate the flowmeter 30 or more pipe diameters downstream from a control valve. This ensures maximum velocity at the flowmeter and produces the most efficient signal from the sensor. This is especially recommended when several flowmeters/control valves are coming off a common header or pipe.

When the flow is more stable, the flowmeter can be mounted a minimum of 5 pipe diameters upstream of the control valve. Pressure fluctuations often are lower on the upstream side of a control valve flow than on the downstream side. This is recommended when a pressure sensor is used with a flowmeter to provide inputs to a flow computer.

On gas flow installations, avoid piping conditions that create standing pockets of liquids inside the meter. The best approach is to install the meter in a vertical line with flow in the upwards direction.

— CAUTION —

For condensate gas applications, take precautions to avoid any trapped condensate that can cause a “water hammer” during startup. If condensate cannot be drained, open the valve slowly, allowing any trapped condensate to travel downstream through the flowmeter at low velocity so that no damage occurs.

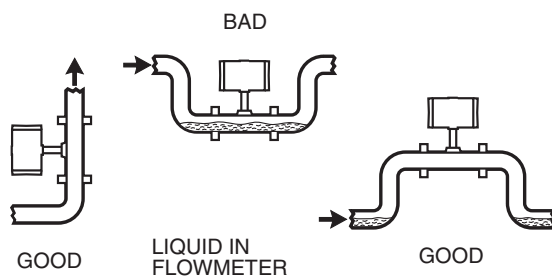

Figure 6. Piping for Gas Applications

When the process fluid is gas, the electronics housing can be above or below the flowmeter body. The normal recommended position of the electronics housing is above the flowmeter body.

Steam Installations

For steam control installations, it is recommended that the flowmeter be mounted 30 pipe diameters or more downstream of the **control** valve. This is particularly useful when measuring saturated steam to ensure that a minimum amount of condensate is present at the flowmeter.

! CAUTION

Take precautions to avoid any trapped condensate that can cause a “water hammer” during startup. If condensate cannot be drained, open the valve slowly, allowing any trapped condensate to travel downstream through the flowmeter at low velocity so that no damage occurs.

Saturated Steam

When the process fluid is saturated steam, the electronics housing should be below the flowmeter body, so that the sensor cavity remains filled when condensate is present. Filling the sensor cavity with condensate results in a less noisy measurement caused by any flashing occurring in the flowmeter due to pressure drop.

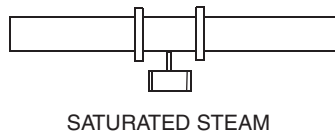

Figure 7. Piping for Saturated Steam Applications

Superheated Steam

When the process fluid is superheated steam, the electronics housing may be above or below the flowmeter body. The flowmeter should be insulated to maintain superheat conditions inside the flowmeter as well as insulating the electronics from heat. Assure that the electronics temperature does not exceed 80°C (176°F) under all flow and environmental conditions.

Insulation

The flowtube may be insulated up to the interface between the bonnet pad and the bonnet. No insulation is allowed beyond the bonnet pad. It is particularly important to insulate the flowtube on applications for superheated steam.

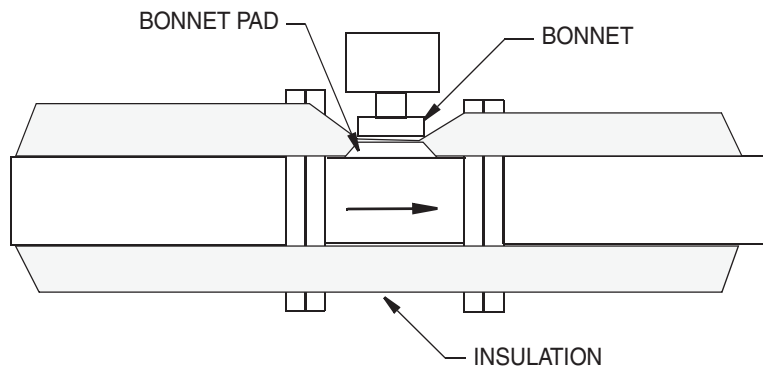

Figure 8. Insulation

Vibration

The vortex shedder axis should be oriented to reduce or, in some cases, virtually eliminate vibration influence. Position the flowmeter so that the sensor axis is perpendicular to the direction of the vibration. See Figure 9.

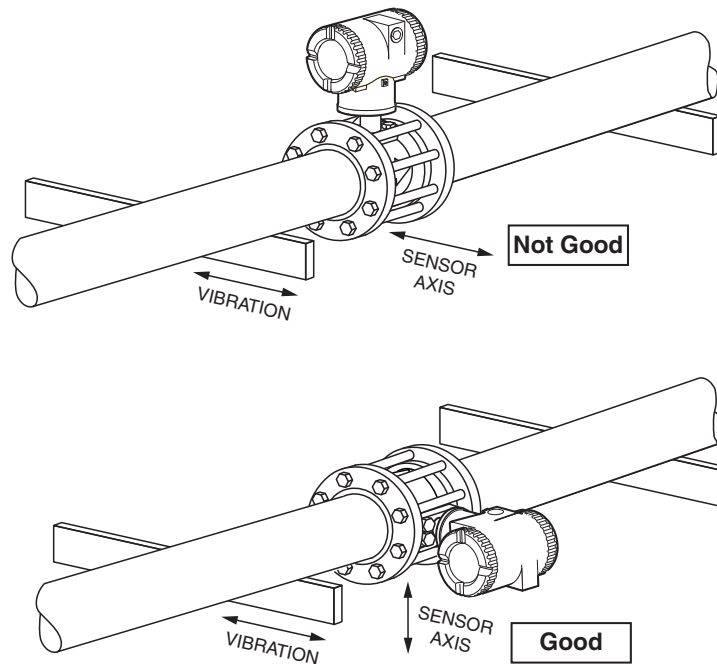

Figure 9. Sensor Mounting to Minimize Effect of Vibration

Ambient Temperature Limitations / Considerations

The temperature limits of the electronics housing is -40 to $+80^{\circ}\text{C}$ (-40°F to $+176^{\circ}\text{F}$). When installing the flowmeter, ambient temperature and proximity to other heat sources must be considered. For extended high temperature applications, this may require positioning the electronics housing to the side or bottom and/or piping insulation to assure the temperature limit is not exceeded. The maximum temperature rating of 80°C is an electrical safety agency requirement for all FM, CSA, IECEx, and ATEX certifications.

In installations where these agency certifications do not apply and ambient temperature limitations are not achievable, remotely mounting the electronics away from the process piping (to a lower temperature area) is recommended. In this configuration, only the preamplifier is in close proximity to the flowmeter and the preamplifier is rated for a maximum temperature of 105°C (221°F).

Table 5. Mounting Arrangements

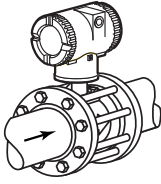
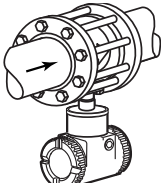
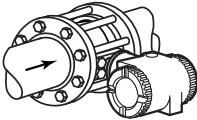
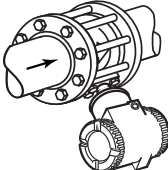
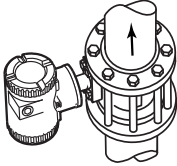
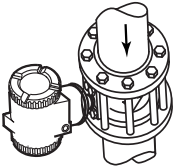
Flowmeter Orientation for Single (Shown) or Dual Measurement Flowmeter		Liquid	Gas	Saturated Steam	Superheated Steam
	Housing above and Isolation valve is not used	Yes (1)	Yes	No	Yes (2)
	Housing above and isolation valve is used	No (5)	Yes	No	Yes (2)
	Housing below pipe	Yes (3, 4, 6)	Yes (4)	Yes	Yes (2)
	Housing to side of pipe	Yes	Yes	No	Yes (2)
	Housing to side and below pipe	Yes (6)	Yes	No	Yes (2)
	Vertical pipe, flow upward	Yes	Yes	No	Yes (2)
	Vertical pipe, flow downward	Yes (7)	Yes	No	Yes (2)

- (1) Possibility of temporary startup error due to trapped air.
(2) Requires adequate insulation.
(3) Best choice when errors due to startup can not be tolerated.
(4) Recommended only for clean fluids.
(5) Not recommended for liquids with isolation valve.
(6) Preferred for liquids with isolation valve.
(7) Not preferred; must maintain full pipe with no voids in fluid.

Meter Servicing

When you install the meter, consider meter repair. The meter should be accessible for servicing. For installations where the flow cannot be interrupted, depressurized, or drained, a flowmeter with an isolation valve is required.

Common practice is to install bypass piping so that the entire meter can be removed for servicing (see Figure 10).

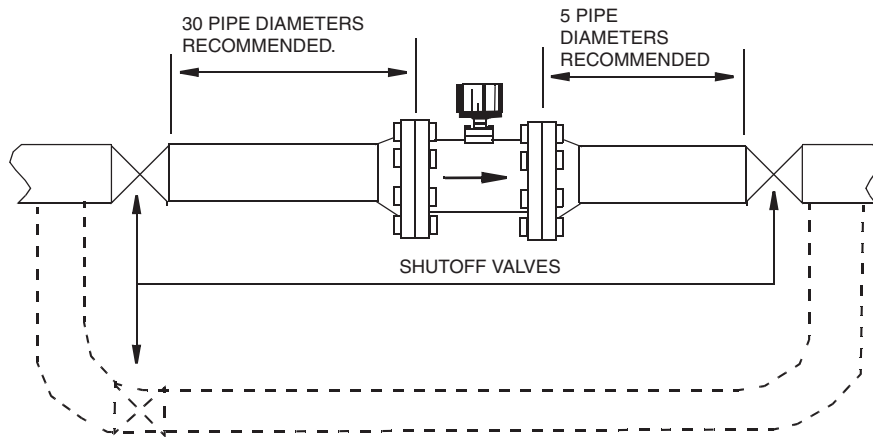

Figure 10. Typical Piping Configuration

Location of Pressure and Temperature Taps

For pressure and/or temperature compensated flow measurement applications, locate the pressure and temperature taps as follows:

— **NOTE**

The inside of the pipe at the pressure and temperature taps must be free of burrs and obstructions.

Pressure Taps -- For density measurement (when required), locate the tap 3-1/2 to 4-1/2 pipe diameters **downstream** of the flowmeter. See Figure 11.

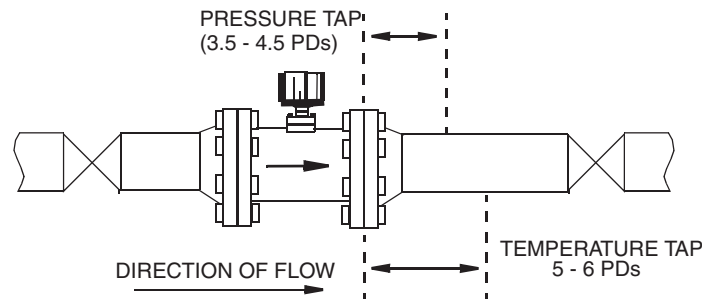

Figure 11. Pressure and Temperature Tap Locations

— **NOTE**

1. On a gas flow installation, the pressure tap should be located on the top of the pipe.
 2. On a liquid installation, the pressure tap (if required) should be located on the side of the pipe.
 3. On a steam installation, the pressure tap should be located on the top when the pressure measuring device (typically a pressure transmitter) is above the pipeline, and on the side when the measuring device is below the pipeline.
 4. With vertical piping, the pressure tap can be located anywhere around the circumference of the pipeline.
-

Temperature Taps -- For temperature measurement (when required), locate the tap 5 to 6 pipe diameters **downstream** of the flowmeter. To reduce flow disturbance, use the smallest possible probe. See Figure 11.

Mechanically Installing the Flowmeter Body

— **NOTE**

If the electronics are mounted remotely, mount the flowmeter body so that the junction box is serviceable.

84F – Flanged Body

1. Gaskets are required and must be supplied by the user. Select a gasket material suitable for the process.
2. Insert gaskets between the body of the flowmeter and adjacent flanges. See Figure 12. Position the gaskets so that the ID of each gasket is centered on the ID of the flowmeter and adjacent piping.

CAUTION — Verify that the ID of the gaskets is larger than that of the flowtube bore and pipe and that the gaskets do not protrude into the flowtube entrance or exit. Protrusion into the flowstream has an adverse effect on performance.

CAUTION — Gaskets do not prevent flanges from being wetted by process fluids.

NOTE — When you install new flanges in the process piping and use the meter as a gauge to set the flanges, protect the inside diameter of the flowmeter from weld splatter. Install a solid sheet of gasketing at each end of the meter during welding. Remove this sheet and install the flange gaskets after welding. Remove any splatter in either the pipe or the meter as it could affect flowmeter accuracy.

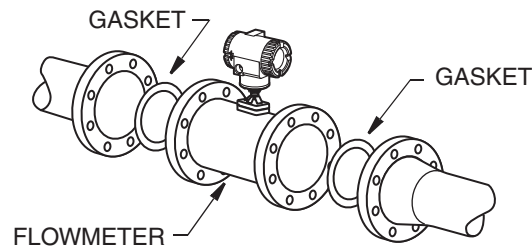

Figure 12. 84F Flowmeter Installation

3. Visually inspect for concentricity (centering and alignment) of mating flanges.
4. Tighten bolts in accordance with conventional flange bolt tightening practice (that is, incremental and alternate tightening of bolts).

84W – Wafer Body

For optimal performance, the wafer body flowmeter should be centered with respect to the adjoining pipe. Normally, this requires the use of centering fixtures that are supplied with the meter.

NOTE — Centering fixtures are not required for meters with ANSI Class 150 flanges.

Most meter sizes have two sets of centering fixtures, but some larger sizes may have twice this number, two for each side.

1. See Figure 13. Insert the first stud through the downstream flange at one of the lower holes, through the two hex-nut spacers, and then through the upstream flange. Place the nuts on both ends of the stud, but do not tighten.
2. Using the remaining hex-nut spacers, repeat Step 1 at the lower hole adjacent to the first.
3. Set the flowmeter between the flanges. Then, rotate spacers to the thickness that centers the meter.

— **NOTE** —

By rotating the hex-nut spacers to the correct thickness, you can center the meter to any type of flange.

4. Gaskets are required and must be supplied by the user. Select a gasket material suitable for the process fluid.
5. Insert gaskets between the body of the flowmeter and adjacent flanges. Position the gaskets so that the ID of each gasket is centered on the ID of the flowmeter and adjacent piping.

—  **CAUTION** —

Verify that the ID of the gaskets is larger than that of the flowtube bore and pipe and that the gaskets do not protrude into the meter entrance or exit. Protrusion into the flowstream has an adverse effect on performance.

— **NOTE** —

If welding the flanges to the process piping is required, protect the flowmeter from weld splatter, which could affect flowmeter accuracy. A solid sheet of gasketing should be installed at each end of the meter during welding. Remove this sheet and install the flange gaskets after welding.

6. Visually inspect for concentricity (centering and alignment) of mating flanges.
7. Install the rest of the studs and nuts and tighten the nuts in accordance with conventional flange bolt tightening practice (that is, incremental and alternate tightening of bolts).

— **NOTE** —

If the adjoining flanges are misaligned, align the wafer body flowmeter with the **upstream** flange.

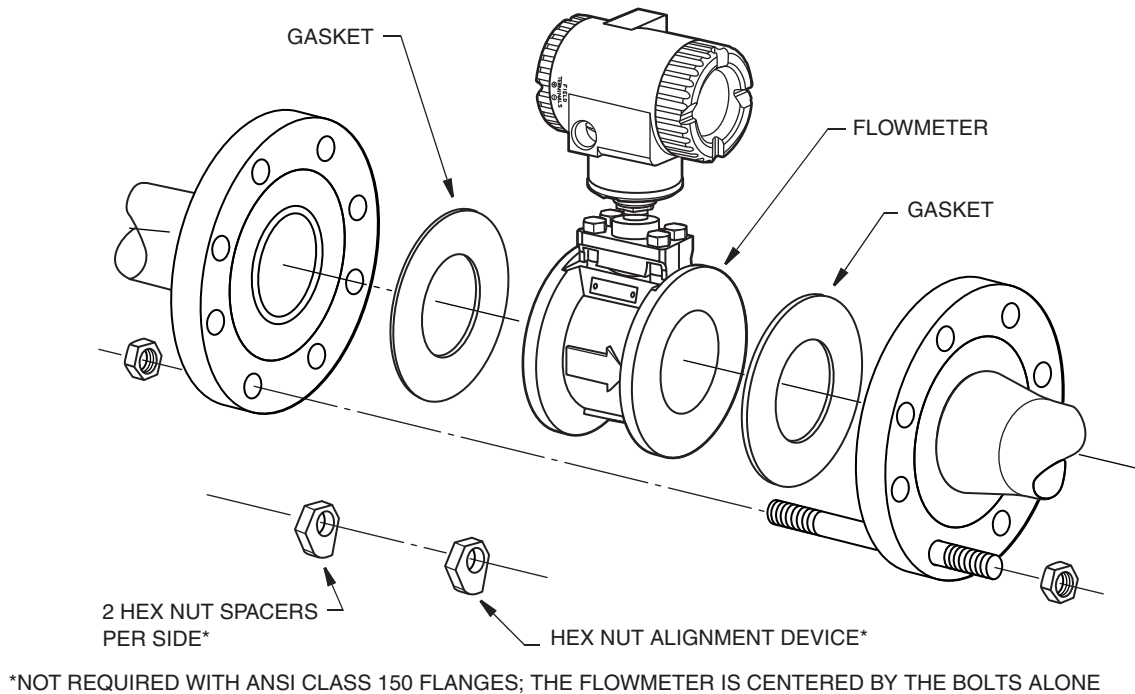

Figure 13. 84W Flowmeter Centering (using Spacers)

Mounting the Remote Electronics Housing

The purpose of the remote electronics housing is to allow for separation of the flowmeter body and the electronics.

A flowmeter with remote electronics consists of:

- ◆ An electronics housing mounted to a pipe or wall mounting bracket with up to 15 m (50 ft) of interconnecting cable attached.
- ◆ A flowmeter body with junction box.

1/2 NPT or M20 conduit connections are provided on both the housing and the junction box.

The remote electronics housing can be mounted to a vertical or horizontal DN 50 or 2-in pipe using the mounting bracket and U-bolt supplied. To mount the housing to a horizontal pipe, turn the U-bolt 90 degrees from the position shown in Figure 14.

The housing can be surface mounted by securing the mounting bracket to a wall using the bracket mounting holes. It may be easier to secure the mounting bracket to the wall without the housing attached. To do this, use the following procedure:

1. Remove the jam nut under the bracket.
2. Raise the housing until you can slide the cable through the cutout in the bracket.
3. Lay the housing aside and secure the mounting bracket to the wall.
4. Reverse steps 2 and 1.

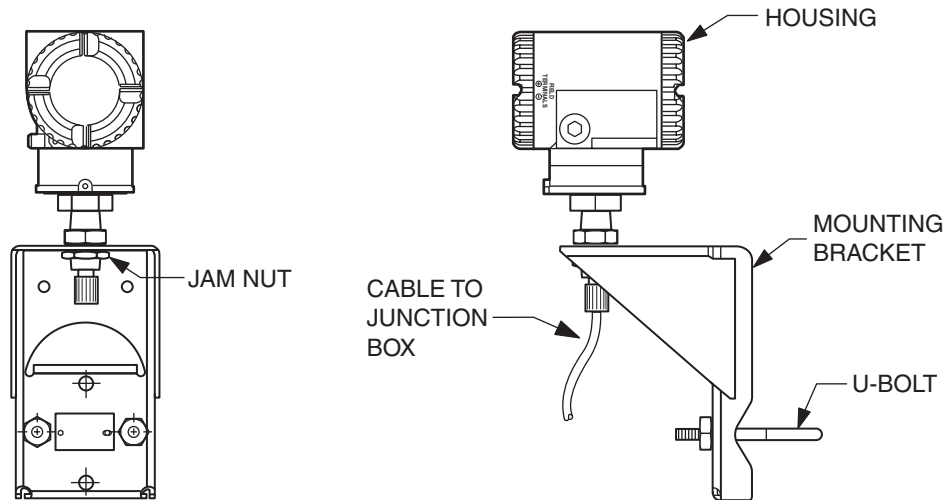

Figure 14. Mounting the Remote Electronics Housing

Cover Locks

Electronic housing cover locks, shown in Figure 15, are provided as standard with certain agency certifications. To lock the covers, unscrew the locking pin until approximately 6 mm (0.25 in) shows, lining up the hole in the pin with the hole in the housing. Insert the seal wire through the two holes, slide the seal onto the wire ends and crimp the seal.

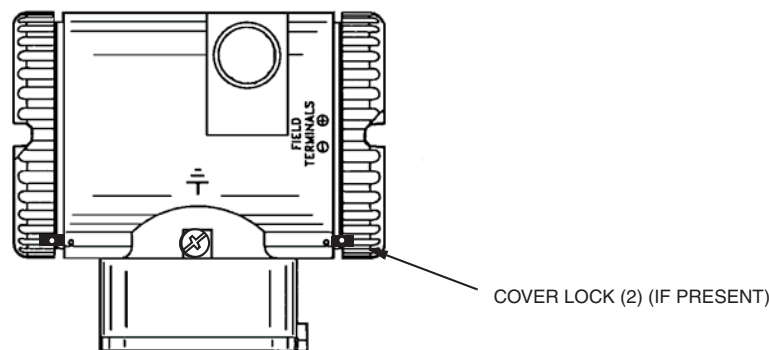

Figure 15. Cover Locks

Positioning the Display

The display (optional in some models) can be rotated within the housing to any of four positions at 90° increments. To do this, loosen the two captive screws, turn the display to the desired position, and retighten the screws.

— CAUTION —

1. Do **not** turn the display more than 180° in any direction. Doing so could damage its connecting cable.

2. Carefully fold the ribbon cable in the space between display and the electronic module so that it is not pinched. The display molding should rest firmly against the module molding before tightening the screws.

Setting the Write Protect Jumper

Your transmitter has write protection capability which meets the security requirements of ISA-S84.01-1986 for use in safety shutdown systems. This means that the local display and remote electronics can be prevented from writing to the electronics. Write protection is set by moving a jumper that is located in the electronics compartment behind the display. To activate write protection, remove the display and remove the jumper or place it in the 'protect' position. In the 'write' position, writing to certain functions can be limited by password protection. See "Password" on page 38.

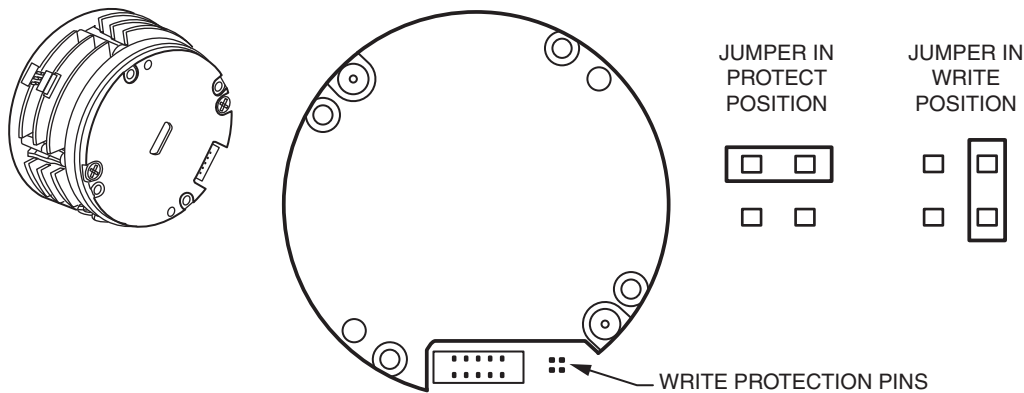

Figure 16. Write Protect Jumper

Positioning the Housing

The flowmeter housing (topworks) can be rotated up to one full turn in the counterclockwise direction when viewed from above for optimum access to adjustments, display, or conduit connections.

— **! WARNING** —

If the electronic housing is removed for any reason, it must be hand tightened fully. Then engage the set screw (see Figure 18) until it bottoms out and back it off 1/8th turn. Fill the set screw recess with red lacquer (Invensys Foxboro Part number X0180GS or equivalent). The housing then may be rotated up to one full turn in a counterclockwise direction for optimum access to adjustments.

Electrical Installation

This section describes procedures for installing wiring, conduit, and ground connections for both integral and remote mounted flowmeters and for preparing remote signal cables for interconnection.

— NOTE —

The wiring installation must be in accordance with local or national regulations applicable to the specific site and classification of the area.

Integrally Mounted Electronics

A flowmeter with a integrally mounted electronics requires only power and output signal wiring. To complete installation, refer to “Field Termination Wiring” on page 29.

Remotely Mounted Electronics

To use the flowmeter as shipped with the cable attached at both ends, mount the electronics housing and flowmeter body within the limits of the cable length.

If the cable must be disconnected (to shorten the cable, run the cable through conduit, or for some other reason), you **must** disconnect the cable at the flowmeter (junction box) end. You cannot disconnect the cable at the electronics housing end because it has been epoxied into the metal connector. It is labeled “Factory Sealed / Electronics End / Do Not Remove.”

Preparing the Remote Signal Cable

If the cable must be shortened or reterminated, the flowmeter (junction box) end of the cable must be prepared per the instructions in Table 6.

Table 6. Preparation of Remote Signal Cable (Junction Box End)





<p>1. Insert the cable into the knurled nut and rubber grommet. Then remove the outer insulation to the dimension shown. Do not damage the copper braid.</p>	
<p>2. Cut the copper braid 1 inch from the end of the outer insulation.</p>	

Table 6. Preparation of Remote Signal Cable (Junction Box End) (Continued)

<p>3. Insert the cable into the fitting until the cable is bottomed out inside the fitting. Rotate the fitting one or two turns to pack the braid into place. Remove the cable and examine the packed braid. If there are still strands of braid that have not packed, push them back by hand and reinsert the cable into the fitting. Remove the cable and examine the braid. It should be compressed to a length of approximately 3/8 to 1/2 inch.</p>	 <p>Note: Fitting is connected to junction box (not shown)</p>
<p>4. Remove the outer clear wrapping and the metalized mylar film to the end of the packed braid. This exposes the inner drain wire. The inner clear wrapping and filler material are still in place.</p>	
<p>5. Make sure that the drain wire is not in contact with the outer braid. Then use an ohm meter to verify that there is no electrical connection between the drain wire and the braid over the entire length of the cable. This step also verifies that the other end (electronics end) of the cable has been properly dressed and that there is no damage or defects in the cable.</p>	
<p>6. Fold the drain wire back onto the packed wire braid and wrap it around one full turn. Then cut off the remainder of the drain wire.</p>	
<p>7. Cut back the inner clear wrapping and the filler to 1/2 to 5/8 inch from the end of the outer insulation.</p>	
<p>8. Cut an 1/2 inch long piece of shrink wrap and position it so that half the wrap covers the inner clear wrapping/filler and half covers the exposed pair of twisted wires. Apply heat to the shrink wrap. Note: A 1/2 inch wide piece of electrical tape can be used in place of the shrink wrap.</p>	
<p>9. Strip the ends of the twisted pair 1/4 inch.</p>	

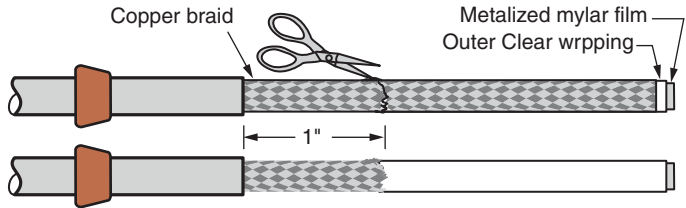
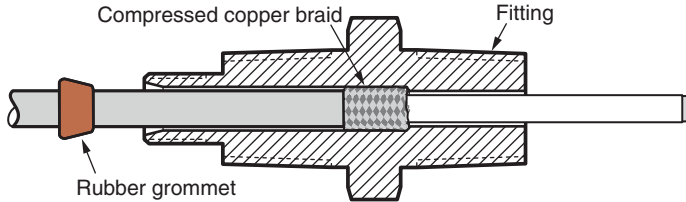
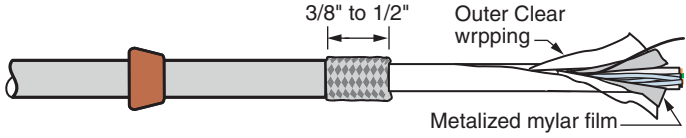
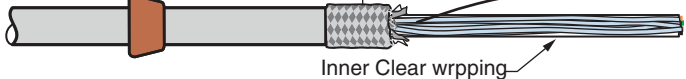
Connecting the Remote Signal Cable

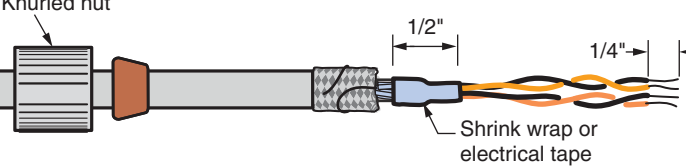
After the cable end has been prepared, connect the cable to the junction box. See Figure 17.

1. Insert the cable into the fitting, making sure that the cable has bottomed out in the fitting.
2. Slide the rubber grommet into the fitting.
3. Screw the knurled nut into place, clamping the rubber grommet against the assembly. Hand tighten with moderate force to assure a water tight connection.
4. Dress the wires in the junction box as shown.

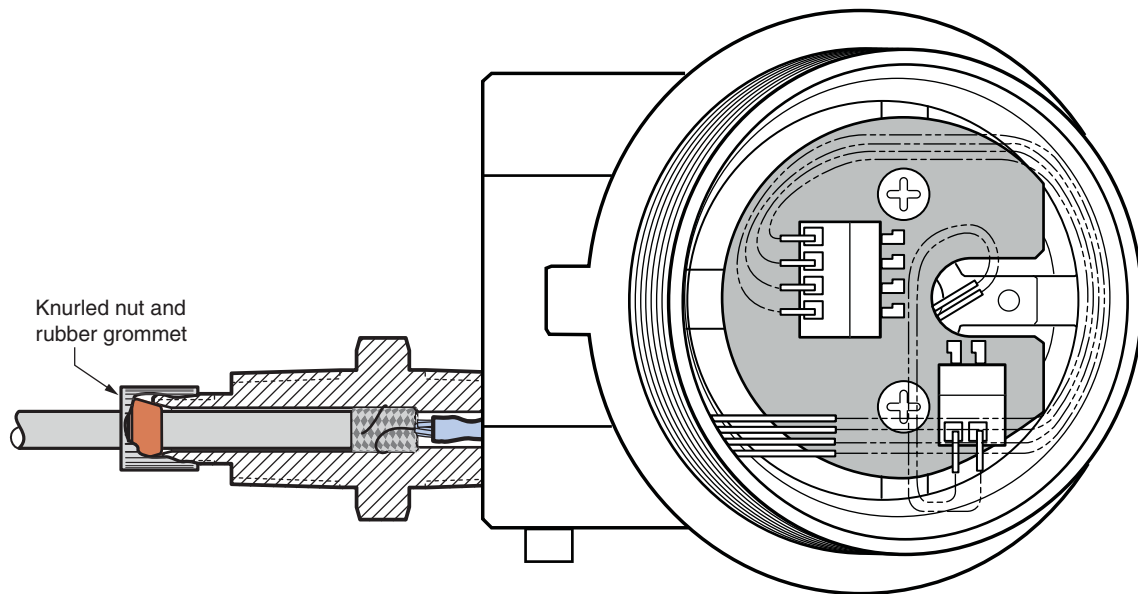

Figure 17. Connection of Remote Signal Cable (Junction Box End)

Installation with Conduit

The remote signal cable is shipped with the cable attached at both ends. To run the cable through conduit, the -T option must have been purchased. This option facilitates a standard 1/2 NPT conduit connection at both the housing end and the flowmeter end.

1. Disconnect the cable at the flowmeter (junction box) end.
2. Slide the remote conduit adapter (part number K0149LE), longer end first, up the cable and attach it at the housing end.
3. Slide the conduit and fittings over the cable.
4. Slide a second remote conduit adapter, shorter end first, onto the cable and attach it at the junction box end.

Explosionproof / Flameproof Certifications

The remote cable provides an explosionproof / flameproof connection at the electronics end. Explosionproof connections beyond this point are not required.

Field Termination Wiring

The installation and wiring of your flowmeter must conform to local code requirements. Also, for FM installations, refer to MI 019-177; for ATEX and IECEx installations, refer to MI 019-179.

— NOTE

Invensys Foxboro recommends the use of transient/surge protection in installations prone to high levels of electrical transients and surges.

Conduit / Cable Gland Connections

The electronics housing has two conduit/cable gland connections to allow access from either side of the housing. These connections are 1/2 NPT or M20 threads per your order. Make sure to use the correct threaded devices when making these connections. The type of thread can be verified by viewing the eighth character after the dash in the model code on the data plate. The letters **T** or **R** indicate a 1/2 NPT thread; **V** or **W**, an M20 thread.

84*-*****x
 └─ ELECTRONICS HOUSING CONDUIT CONNECTIONS

The housing comes with a safety-agency approved threaded metal plug in one of the conduit holes and a plastic plug in the other. After the conduit or cable gland is connected, plug the unused hole with the metal plug.

Accessing Flowmeter Field Terminals

For access to the field terminals, remove the cover from the field terminals compartment as shown in Figure 18. Note that the embossed letters **FIELD TERMINALS** identify the proper compartment.

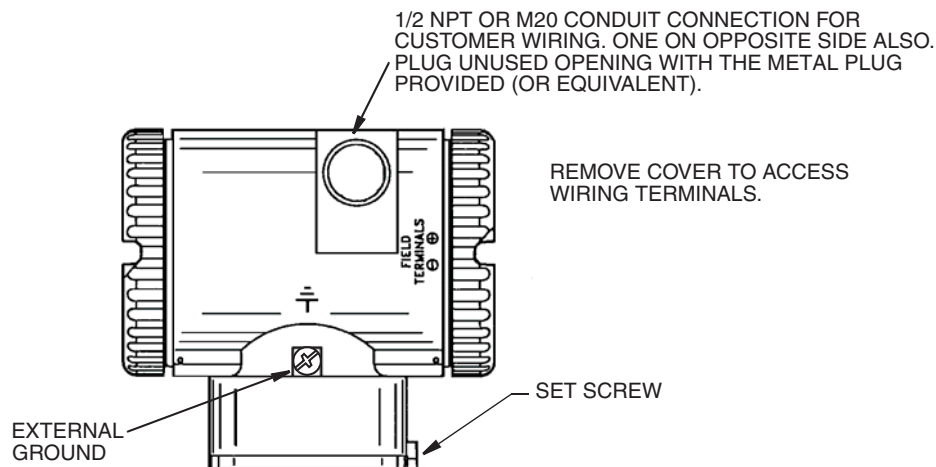

Figure 18. Accessing Field Terminals

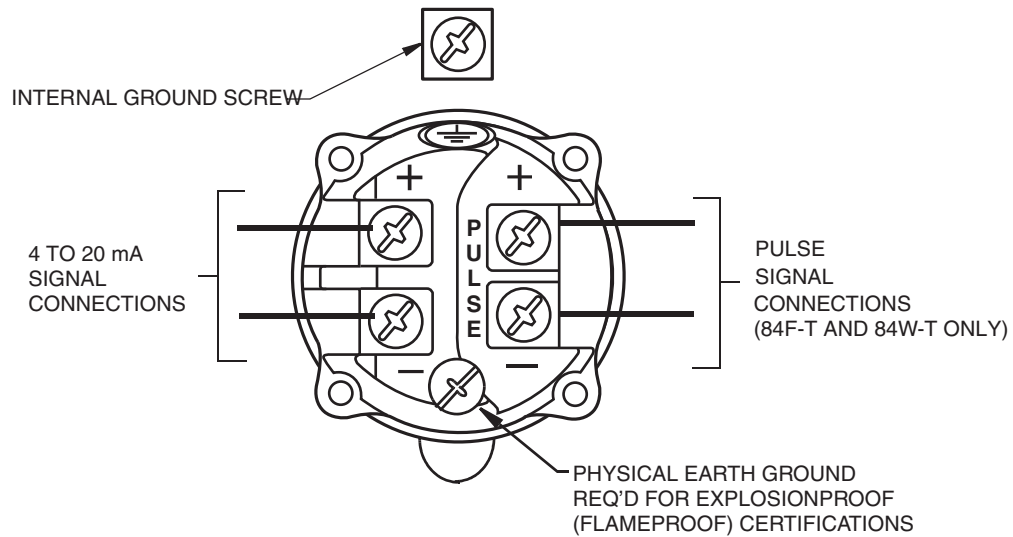

Figure 19. Identification of Field Terminals

Wiring the Flowmeter to a Control Loop

— NOTE —

To use a 4-20 mA output signal, your flowmeter must be configured for **4-20 mA**.

When wiring a flowmeter with 4 to 20 mA output signal, the supply voltage and loop load must be within specified limits. The supply output load vs. voltage relationship is shown in Figure 20.

Any combination of supply voltage and loop load resistance in the shaded area can be used. To determine the loop load resistance (flowmeter output load), add the series resistance of each component in the loop, excluding the flowmeter. The power supply must be capable of supplying 22 mA of loop current.

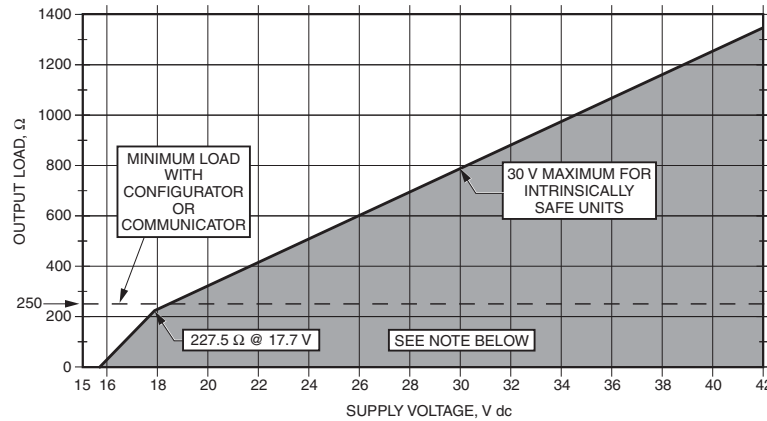

NOTE:
 THE FLOWMETER FUNCTIONS WITH AN OUTPUT LOAD LESS THAN 250 Ω PROVIDED THAT A PC-BASED CONFIGURATOR OR HART COMMUNICATOR IS NOT CONNECTED TO IT. CONNECTING A PC-BASED CONFIGURATOR OR HART COMMUNICATOR WHILE OPERATING BELOW A 250 Ω LOAD MAY CAUSE OUTPUT DISTURBANCE AND/OR COMMUNICATION PROBLEMS.

Figure 20. Supply Voltage and Loop Load

Examples:

1. For a loop load resistance of 300 Ω , the supply voltage can be any value from 19.1 to 30 V dc.
2. For a supply voltage of 24 V dc, the loop load resistance can be any value from 250 to 520 Ω (zero to 520 Ω without a HART Communicator or PC-Based Configurator connected to the flowmeter).

To wire one or more flowmeters to a power supply, proceed with the following steps.

1. Remove the cover from the field terminals compartment.
2. Run signal wires (0.50 mm² or 20 AWG, typical) through one of the flowmeter conduit connections. Use twisted pair to protect the 4 to 20 mA output and/or remote communications from electrical noise. Maximum recommended length for signal wires is 1800 m (6000 ft)

— NOTE

Do **not** run flowmeter wires in same conduit as mains (ac power) wires.

3. If shielded cable is used, ground the shield at the receiver **only**. Do **not** ground the shield at the flowmeter.
4. Plug the unused conduit opening with the 1/2 NPT or M20 metal plug provided (or equivalent). To maintain specified explosionproof and dust-ignitionproof protection, the plug must engage a **minimum** of five full threads.
5. The flowmeter is equipped with an internal and external ground connection. Connect a ground wire to either terminal in accordance with local practice.

⚠ CAUTION

If the signal circuit must be earthed (grounded), it is preferable to do so at the negative terminal of the dc power supply. To avoid errors resulting from earth loops or the possibility of short-circuiting groups of instruments in a loop, there should be only one earth in a loop.

6. Connect the power supply and receiver loop wires to the “+” and “-” terminal connections.
7. Connect receivers (such as controllers, recorders, indicators) in series with power supply and flowmeter as shown in Figure 21.
8. Install the cover onto the flowmeter. Turn the cover to seat the O-Ring into the housing and continue to hand tighten until the cover contacts the housing metal-to-metal. If cover locks are present, refer to “Cover Locks” on page 24.
9. If wiring additional flowmeters to the same power supply, repeat Steps 1 through 8 for each additional flowmeter.
10. A HART Communicator or PC-based Configurator can be connected in the loop between the flowmeter and the power supply as shown in Figure 21. Note that a minimum of 250 Ω must separate the power supply from the HART Communicator or PC-Based Configurator.

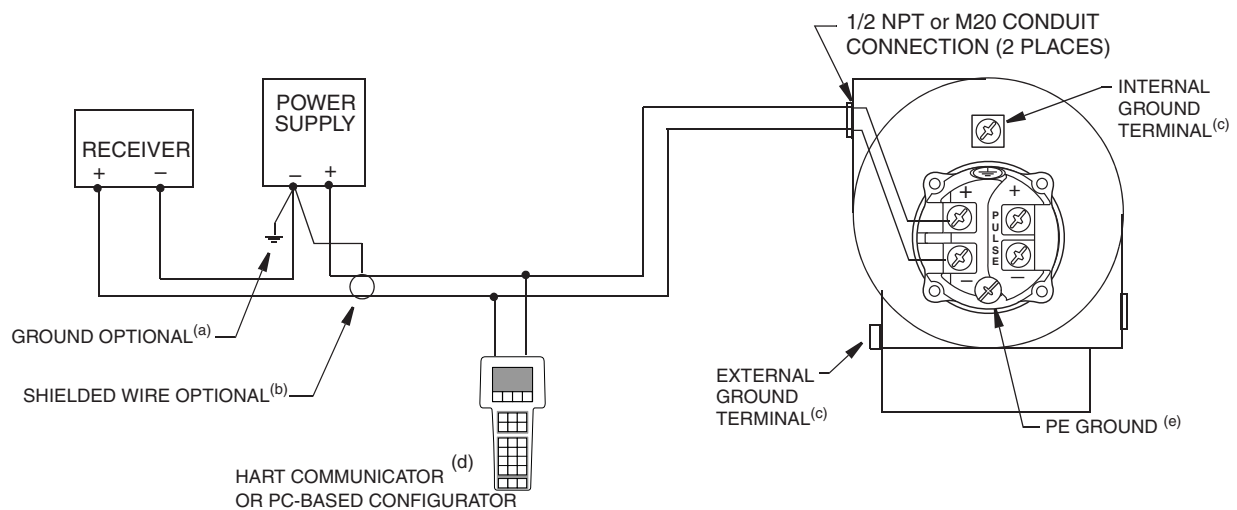

- (a) GROUNDING THE LOOP AT THE NEGATIVE TERMINAL OF THE POWER SUPPLY IS RECOMMENDED BUT NOT REQUIRED.
- (b) IF SHIELDED WIRE IS USED, TERMINATE THE SHIELD AT THE NEGATIVE TERMINAL OF THE POWER SUPPLY.
- (c) THE TRANSMITTER IS EQUIPPED WITH AN INTERNAL AND EXTERNAL GROUND CONNECTION. CONNECT A GROUND WIRE TO EITHER TERMINAL IN ACCORDANCE WITH LOCAL PRACTICE.
- (d) THERE MUST BE AT LEAST 250 Ω TOTAL RESISTANCE BETWEEN THE PC-BASED CONFIGURATOR OR THE HART COMMUNICATOR AND THE POWER SUPPLY.
- (e) REQUIRED FOR EXPLOSIONPROOF (FLAMEPROOF) APPLICATIONS

Figure 21. Loop Wiring 4 to 20 mA Output Flowmeters

Multidrop Communication

“Multidropping” refers to the connection of several flowmeters to a single communications transmission line. Communications between the host computer and the flowmeters takes place digitally with the analog output of the flowmeter deactivated. With the HART communications protocol, up to 15 flowmeters can be connected on a single twisted pair of wires or over leased telephone lines.

The application of a multidrop installation requires consideration of the update rate necessary from each flowmeter, the combination of flowmeter models, and the length of the transmission line. Multidrop installations are not recommended where Intrinsic Safety is a requirement. Communication with the flowmeters can be accomplished with any HART compatible modem and a host implementing the HART protocol. Each flowmeter is identified by a unique address (1-15) and responds to the commands defined in the HART protocol.

Figure 22 shows a typical multidrop network. Do not use this figure as an installation diagram. Contact the HART Communications Foundation, (512) 794-0369, with specific requirements for multidrop applications.

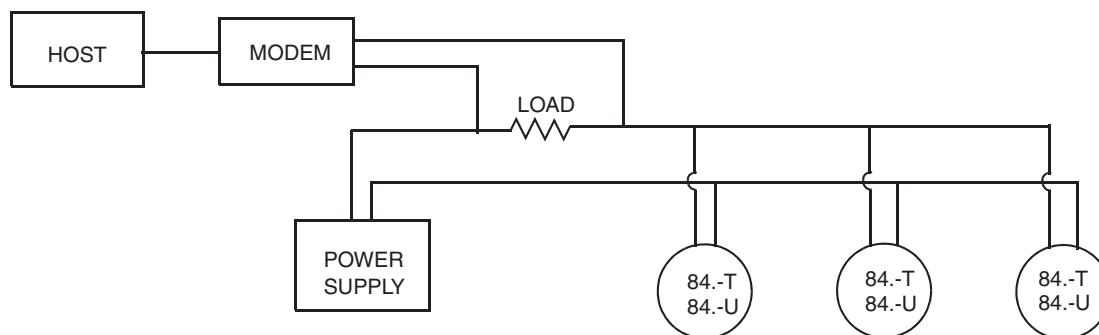

Figure 22. Typical Multidrop Network

The HART Communicator can operate, configure, and calibrate 84 Series Flowmeters with HART communication protocol in the same way as it can in a standard point-to-point installation.

— NOTE —

84 Series Flowmeters with HART communication protocol are set to poll address 0 (**POLLADR 0**) at the factory, allowing them to operate in the standard point-to-point manner with a 4 to 20 mA output signal. To activate multidrop communication, the flowmeter address must be changed to a number from 1 to 15. Each flowmeter must be assigned a unique number on each multidrop network. This change deactivates the 4 to 20 mA analog output.

Wiring a Flowmeter With a Pulse Output

Two separate loops are required when using the pulse output on an 84F-T or 84W-T Flowmeter with the 4 to 20 mA or digital signal. Each loop requires its own power supply. Figure 23 shows the connections with a transistor switch (sinking) counter input with receiver supplied power; Figure 24, with a transistor switch (sinking) counter input and external power supply and pull-up

resistor; and Figure 25 with a transistor switch (sourcing) counter input and external power supply and pull-up resistor.

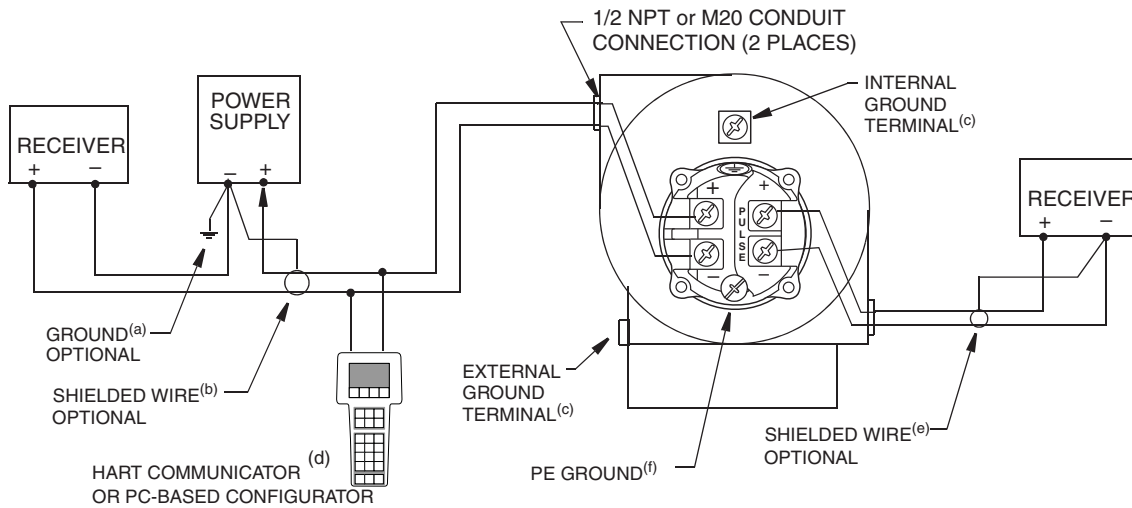

- (a) GROUNDING THE LOOP AT THE NEGATIVE TERMINAL OF THE POWER SUPPLY IS RECOMMENDED BUT NOT REQUIRED.
 (b) IF SHIELDED WIRE IS USED, TERMINATE THE SHIELD AT THE NEGATIVE TERMINAL OF THE POWER SUPPLY.
 (c) THE TRANSMITTER IS EQUIPPED WITH AN INTERNAL AND EXTERNAL GROUND CONNECTION. CONNECT A GROUND WIRE TO EITHER TERMINAL IN ACCORDANCE WITH LOCAL PRACTICE.
 (d) THERE MUST BE AT LEAST 250 Ω TOTAL RESISTANCE BETWEEN THE PC-BASED CONFIGURATOR OR THE HART COMMUNICATOR AND THE POWER SUPPLY.
 (e) IF SHIELDED WIRE IS USED, TERMINATE THE SHIELD AT THE NEGATIVE TERMINAL OF THE RECEIVER.
 (f) REQUIRED FOR EXPLOSIONPROOF (FLAMEPROOF) APPLICATIONS.

Figure 23. Wiring an 84F-T or 84W-T Flowmeter with a Pulse Output Transistor Switch (sinking) Counter Input with Receiver Supplied Power

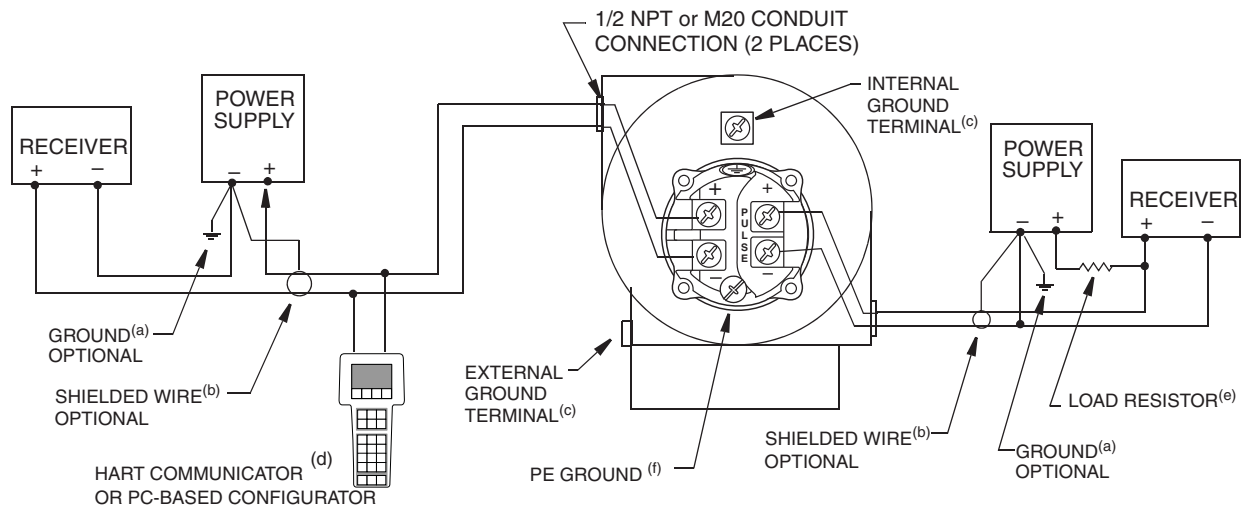

- (a) GROUNDING THE LOOP AT THE NEGATIVE TERMINAL OF THE POWER SUPPLY IS RECOMMENDED BUT NOT REQUIRED.
- (b) IF SHIELDED WIRE IS USED, TERMINATE THE SHIELD AT THE NEGATIVE TERMINAL OF THE POWER SUPPLY.
- (c) THE TRANSMITTER IS EQUIPPED WITH AN INTERNAL AND EXTERNAL GROUND CONNECTION. CONNECT A GROUND WIRE TO EITHER TERMINAL IN ACCORDANCE WITH LOCAL PRACTICE.
- (d) THERE MUST BE AT LEAST 250 Ω TOTAL RESISTANCE BETWEEN THE PC-BASED CONFIGURATOR OR THE HART COMMUNICATOR AND THE POWER SUPPLY.
- (e) MAXIMUM PULSE OUTPUT CURRENT IS 20 mA. LOAD RESISTOR MUST BE SIZED ACCORDINGLY.
- (f) REQUIRED FOR EXPLOSIONPROOF (FLAMEPROOF) APPLICATIONS.

Figure 24. Wiring an 84F-T or 84W-T Flowmeter with a Pulse Output Transistor Switch (sinking) Counter Input with External Power Supply and Pull-Up Resistor

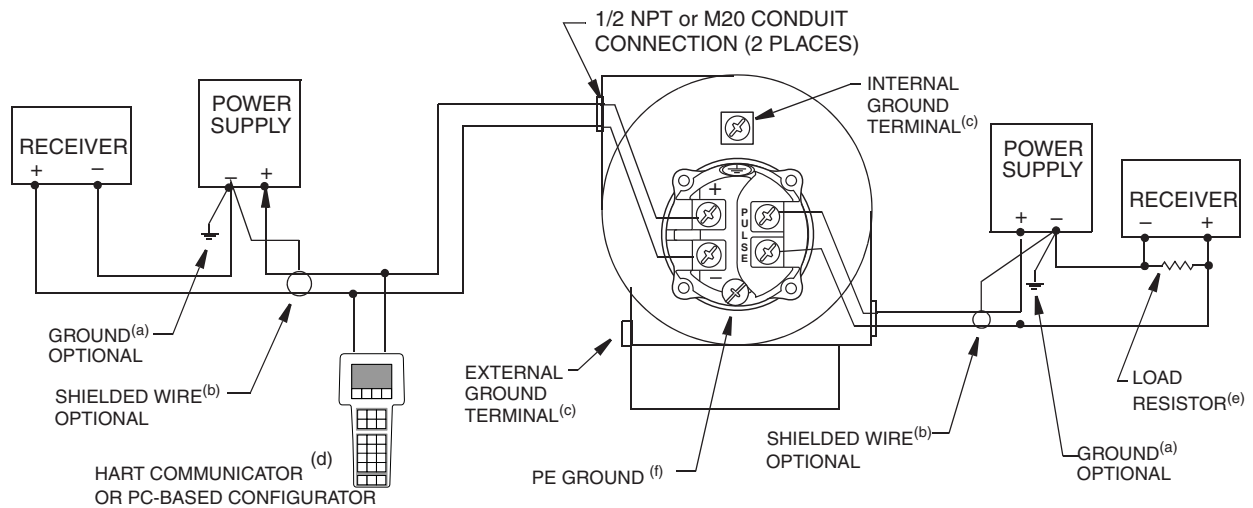

- (a) GROUNDING THE LOOP AT THE NEGATIVE TERMINAL OF THE POWER SUPPLY IS RECOMMENDED BUT NOT REQUIRED.
- (b) IF SHIELDED WIRE IS USED, TERMINATE THE SHIELD AT THE NEGATIVE TERMINAL OF THE POWER SUPPLY.
- (c) THE TRANSMITTER IS EQUIPPED WITH AN INTERNAL AND EXTERNAL GROUND CONNECTION. CONNECT A GROUND WIRE TO EITHER TERMINAL IN ACCORDANCE WITH LOCAL PRACTICE.
- (d) THERE MUST BE AT LEAST 250 Ω TOTAL RESISTANCE BETWEEN THE PC-BASED CONFIGURATOR OR THE HART COMMUNICATOR AND THE POWER SUPPLY.
- (e) MAXIMUM PULSE OUTPUT CURRENT IS 20 mA. LOAD RESISTOR MUST BE SIZED ACCORDINGLY.
- (f) REQUIRED FOR EXPLOSIONPROOF (FLAMEPROOF) APPLICATIONS.

Figure 25. Wiring an 84F-T or 84W-T Flowmeter with a Pulse Output Transistor Switch (sourcing) Counter Input with External Power Supply and Pull-Up Resistor

3. Operation Via Local Display

Communication with the 84F-T, 84F-U, 84W-T, and 84W-U Vortex Flowmeters is carried out using the HART Communicator, a PC-Based configurator, or the optional Local Keypad/Display. General instructions for using the HART Communicator can be found in MAN 4250, HART Communicator Product Manual. Instructions for using the HART Communicator with an 84 Series flowmeter is located in Section 4 of this document. Instructions for using the PC-Based configurator are included with the configurator software. Instructions for using the Local Keypad/Display is found in this section.

— NOTE —

For proper communication with a HART Communicator, the communicator must contain the proper DD for the 84 Vortex Flowmeter. This DD is available from Invensys Foxboro, or any other authorized HART Foundation source.

Local Keypad/Display

A local display, as shown in Figure 26 provides local indication of the measurement information, function status, and reference information. The display also provides a means of performing totalizer reset, and full configuration, calibration, and self-test. Operation is accomplished via four multi-function keys.

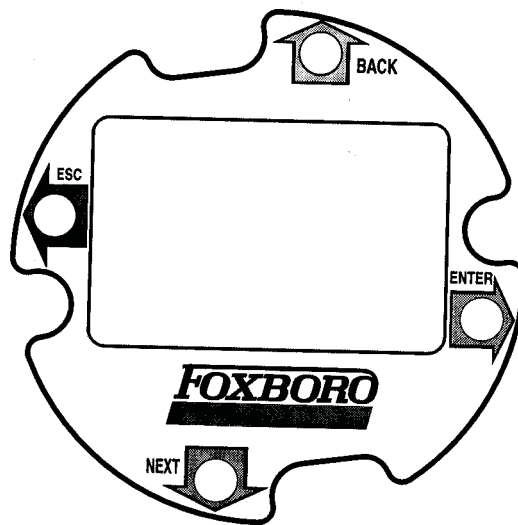

Figure 26. Local Display

Table 7. Operation of Function Keys

Key	Function
Left Arrow (ESC)	Moves left in the menu structure. Moves the cursor to the left in a data entry field. Escapes from changes in a picklist menu or data entry.* Answers No.
Right Arrow (ENTER)	Moves right in the menu structure. Used to access the data entry edit mode of a parameter. Moves the cursor to the right in a data entry field. Enters and saves the changed menu picklist choices or data entry.* Answers Yes.
Up Arrow (BACK)	Moves upward in the menu structure, a picklist menu, or list of characters.
Down Arrow (NEXT)	Moves downward in the menu structure, a picklist menu, or list of characters.

*On data entry, repeatedly press the key until the cursor reaches the end of the display.

Display Bar Indicator

The bar indicator at the top of the display indicates the flow measurement, as a percentage of the upper range value.

— NOTE

If the flow measurement is out-of-range, the bar indicator blinks.

If the flowmeter is off-line, the middle four bars of the bar indicator blink.

Password

Display of information requires no password. However, the ability to access certain functions, (for purposes other than Read Only), such as totalizer, setup, and calibration/testing, may require a user-definable password. The **LoPwd** allows you to reset the Net Totalizer and Pulse Totalizer. The **HiPwd** gives you access to all flowmeter functions. In addition, the write protect jumper must be in the 'write' position. See "Setting the Write Protect Jumper" on page 25.

— NOTE

The flowmeter is shipped from the factory with a blank password. This allows access to all flowmeter functions. If password protection is required, enter a **LoPwd** and/or **HiPwd** in Setup mode.

Entering the Password

The totalizer, setup, and calibration/test functions may require a password (a 4-character alphanumeric string). Select the **TotPul**, **TotNet**, **TotGrd**, **Setup** or **Cal/Tst** top level menu and press **Enter** at the password prompt. Two brackets surrounding four spaces ([_ _ _ _]) then appear on the second line of the display. The cursor, a flashing icon, appears at the first character.

To enter the password, use the Up/Down arrow keys to scroll through the list of acceptable characters. After selecting the desired character, press the Right arrow key to move to the next character. Continue this process until the password is complete. Pressing the Right arrow key once more moves the flashing cursor to the right bracket. Pressing **Enter** now completes the process. Prior to pressing **Enter**, you can use the Left/Right arrow keys to move back and forth to modify an incorrect selection.

If you enter an incorrect password, the display indicates **Sorry** for one second, then goes to Read Only.

You can change a password in the **Passwd** parameter in the Setup menu.

Activating an Edit, Pick-List, or User Menu Block

To open a menu block that allows you to edit or select data or to perform a function, move to the menu block and press the Right arrow (**Enter**) key.

Editing Numbers and Strings

Editing any number or string in the menu system is done in the same way as entering the password. The Up/Down arrow keys scroll through a list of acceptable characters for the current position. The Right arrow key moves the cursor to the right. It also accepts the change at the end. The Left arrow key moves the cursor to the left. It also cancels the change at the beginning.

There are three kinds of edit items: signed numbers, unsigned numbers, and strings.

Signed Numbers

Signed numbers always have a + or - sign at the beginning. The + can only be changed to –, and vice versa.

Unsigned Numbers

For unsigned numbers, cycle through the digits 0-9, and the decimal point, with the Up/Down arrow keys. When you enter a decimal point in any position, and there is already a decimal point to the left of the cursor, the new decimal point overrides the old one.

Strings

Characters in strings can be changed to any valid character. You can sequence through the list of characters by pressing the Up/Down arrow keys. To enter the change, you must still press **Enter** from the right side of the data field, after scrolling to the right side with the Right arrow key.

Picking from a List

Picklist items allow you to choose a selection from a flowmeter-supplied list of alternatives. Go to the applicable parameter, and press **Enter**. The entire bottom line of the display flashes. If you press the Up/Down arrow keys, the display shows the previous or next choice respectively from its list. Pressing **Enter** accepts the change; pressing **Esc** returns the previous selection.

Configuration Database

Each flowmeter is shipped from the factory with an operating configuration database. However, the flowmeter will not provide an accurate measurement if the configuration does not fit your application. **Be sure to check the configuration of our flowmeter prior to start-up.**

If the user information is not supplied with the purchase order, the flowmeter is shipped with the following defaults:

Table 8. Default Database When User Information Not Supplied

Item	Metric	English
Fluid Type	Liquid (water)	Liquid (water)
Type of Flow	Volume	Volume
Measurement Units	m ³ /s	ft ³ /min
Flowing Temperature	20°C	68°F
Flowing Density	998.21 kg/m ³	62.316 lb/ft ³
Base Density (N/A)	999.20 kg/m ³	62.378 lb/ft ³
Absolute Viscosity	1.002 cP	1.002 cP
Upper Range Value	Upper Range Limit for Flowmeter Size	Upper Range Limit for Flowmeter Size

These defaults are **not** recommended for general operation. If no other process information is available, entering **Liquid**, **Gas**, or **Steam** as fluid type in **Setup > Fluid > New** establishes default data bases as shown in Tables 9, 10, or 11 respectively.

Table 9. Default Database for Liquid

Parameter	Metric	English
Fluid Type	Liquid (water)	Liquid (water)
Type of Flow	Same as present configuration (exceptions)	
Measurement Units	Same as present configuration (exceptions)	
Flowing Temperature	20°C	68°F
Flowing Density	998.21 kg/m ³	62.316 lb/ft ³
Base Density (N/A)	999.20 kg/m ³	62.378 lb/ft ³
Absolute Viscosity	1.002 cP	1.002 cP
Upper Range Value	Upper Range Limit for Flowmeter Size	Upper Range Limit for Flowmeter Size

Table 10. Default Database for Gas

Parameter	Metric	English
Fluid Type	Gas (air)	Gas (air)
Type of Flow	Same as present configuration (exceptions)	

Table 10. Default Database for Gas (Continued)

Parameter	Metric	English
Measurement Units	Same as present configuration (exceptions)	
Flowing Temperature	20°C	68°F
Flowing Density	9.546 kg/m ³	0.596 lb/ft ³
Base Density	1.293 kg/m ³	0.0807 lb/ft ³
Absolute Viscosity	0.0185 cP	0.0185 cP
Upper Range Value	Upper Range Limit for Flowmeter Size	Upper Range Limit for Flowmeter Size

Table 11. Default Database for Steam

Parameter	Metric	English
Fluid Type	Steam	Steam
Type of Flow	Volume	Volume
Measurement Units	m ³ /s	ft ³ /s
Flowing Temperature	178.2°C	352.8°F
Flowing Density	4.966 kg/m ³	0.310 lb/ft ³
Absolute Viscosity	0.015 cP	0.015 cP
Upper Range Value	Upper Range Limit for Flowmeter Size	Upper Range Limit for Flowmeter Size

Using the Menu Tree

Moving Inside the Menu System

Pressing the **Enter** key stops the display of measurements and shows the first top level Totalizer menu item, 1 **TotPul**. Use the Down arrow key to go to 1 **TotNet** and 1 **Tot Grd**. At any one of these choices, press **Enter** to edit your selection. Use the Down arrow key to select Off (turn the totalizer off), On (turn the totalizer on), or Clear (reset the totalizer) and then press **Enter**. Press the **ESC** key to return to Measure mode.

Pressing the **Esc** key stops the display of measurements, and shows the first item in the rest of the top level menu, 1 **Measure**. From here, the four keys allow you to move around the menu tree, as indicated by the arrows. Press the Down arrow key to cycle through each of the current menu level items. Press the Right arrow key to move from the current level to its submenu level. Press the Left arrow key to move from the current level to the next higher level.

— NOTE —

Each menu item has its level (1 - 5) displayed at the beginning of the top line.

Top Level Menu

The three totalizer items in the main menu were discussed immediately above. The remainder of the Top Level menu displays six modes – Measure, Status, View, Setup, and Calibration/Test. You

can switch from one to another in sequence by using the Up/Down arrow keys. To enter the second level menu from a particular top level display, press the Right arrow key. To return to the top level from a second level menu item, press the Left arrow key. The level of the first, second, third, fourth, and fifth level menus is indicated by the digit appearing as the first character in Line 1 of the display; a 1 indicates Level 1 (Top Level), a 2 indicates Level 2, and a 3 indicates Level 3, and so forth.

The top level menu is shown in Figure 27.

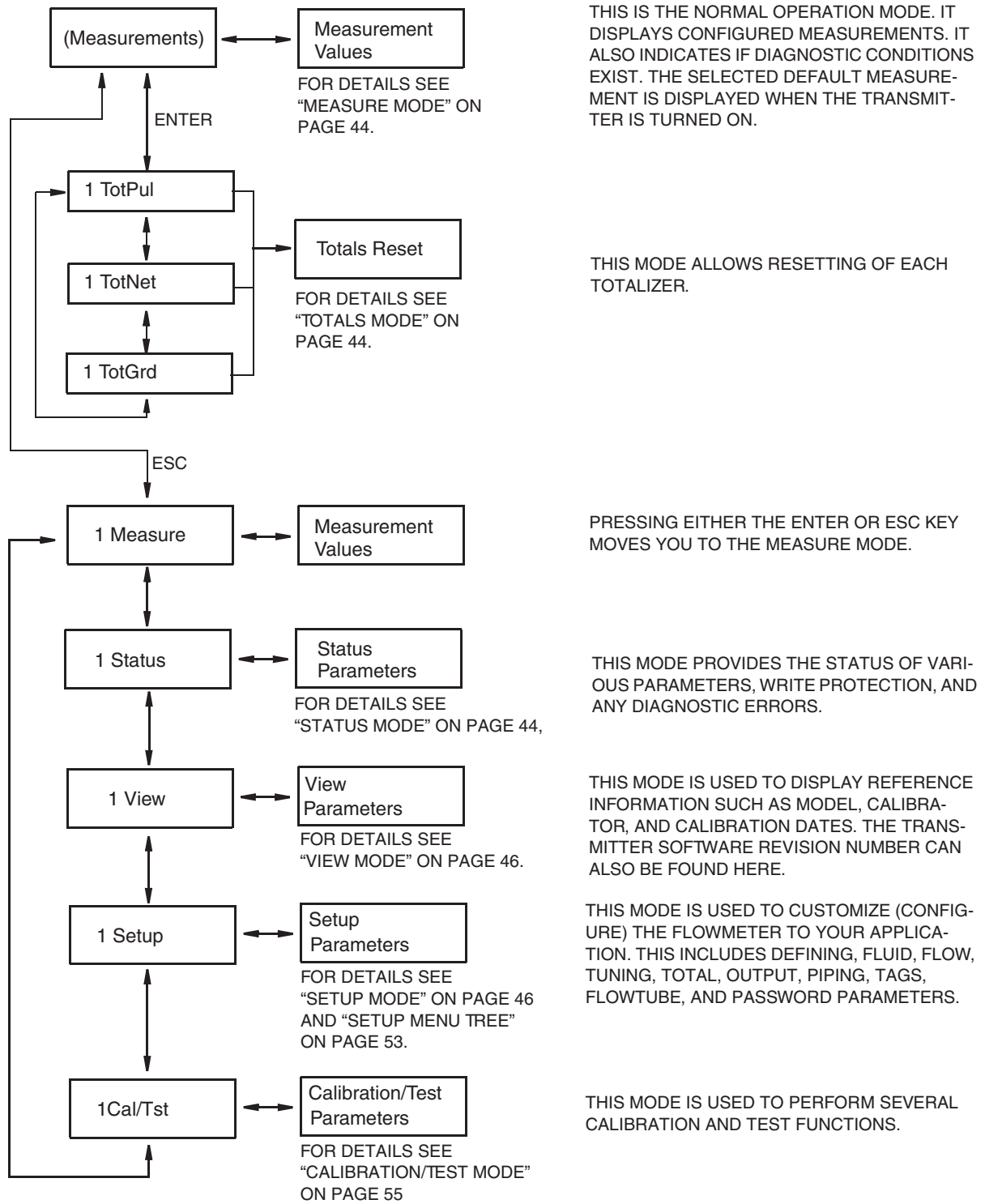

Figure 27. Top Level Modes and Their Basic Functions

NOTE
 Certain parameters may be missing as you step through the menus described in this chapter depending on the configuration of your instrument.

Measure Mode

In normal operation, the flowmeter displays those measurements specified in Setup mode. If configured for **Manual** cycle, you can cycle through the measurements manually by using the Up/Down arrow keys. If configured for **Auto** cycle, the display cycles through the measurements specified. If, while in **Auto** cycle, you want to see a specific measurement momentarily, advance to that measurement with the Down arrow key. Use the Up arrow key to go to a specific measurement and stay there. You can then resume scanning by pressing the Down arrow key.

Totals Mode

TotPul, **TotNet**, or **TotGrd** is used to turn a totalizer on, pause the totalizer, or to clear (reset) the total. This is done by pressing the **Enter** key and selecting **On**, **Paused**, or **Clear** and pressing the **Enter** key again. Before doing this you may be asked for a password. If so, enter the **LoPwd** or **HiPwd** for **TotPul** and **TotNet**; enter the **HiPwd** for **TotGrd**.

— **NOTE** —

Clearing **TotGrd** also clears **TotPul** and **TotNet**.

Status Mode

The **MeaStat** sublevel of this mode enables you to view the units, value, and status of system parameters and thus assess the performance of the loop. You can not edit them in this mode. To step through the displays of the parameters, use the Up/Down arrow keys. The Status mode structure diagram is shown in Figure 28.

The **WrProt** sublevel of this mode shows whether write protection is enabled (**Prot**) or is disabled (**NotProt**).

The **DiagEr** sublevel of this mode shows any diagnostic errors. The display **0000** means no diagnostic errors.

— **NOTE** —

A new diagnostic condition only appears after a diagnostic is detected while in Measure mode.

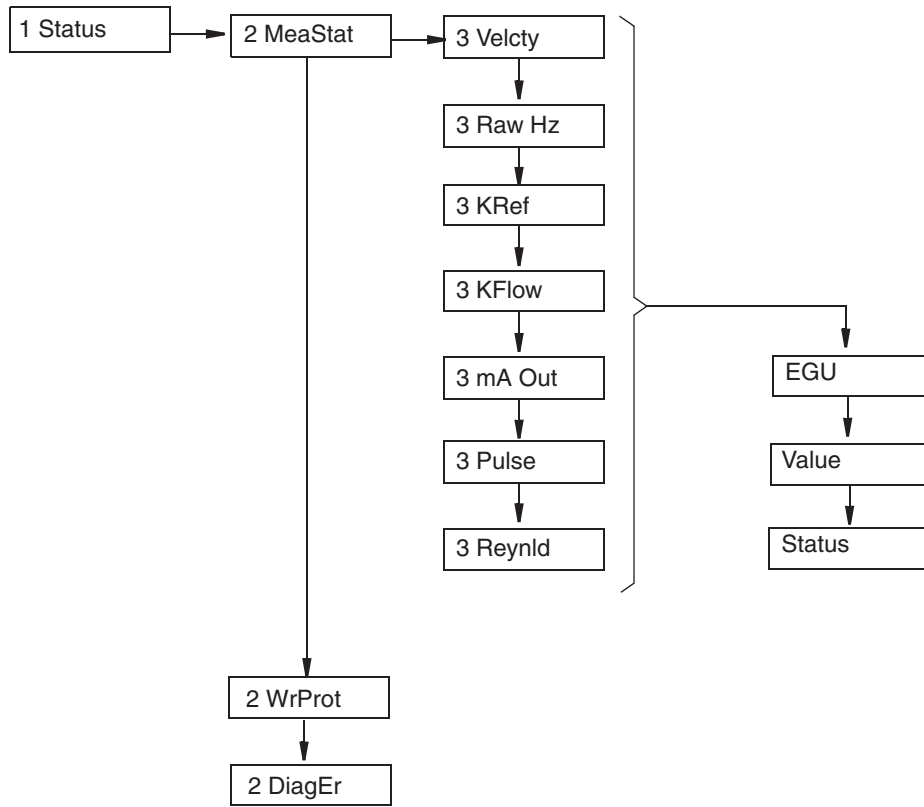

Figure 28. Status Mode Structure Diagram

View Mode

The View mode enables you to view the identity parameters. You can not edit them in this mode. To step through the list of the following parameters, use the Up and Down arrow keys.

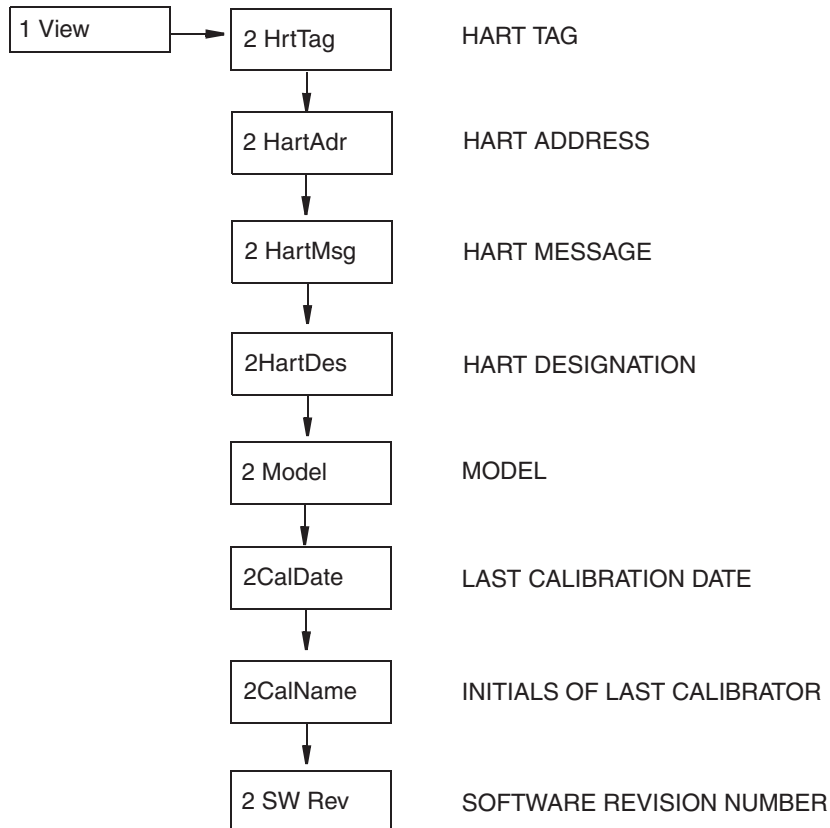

Figure 29. View Mode Structure Diagram

Setup Mode

The Setup mode enables you to configure your flowmeter fluid, flow, tuning, totalizer, output, pipe, tag, flowtube, and password parameters. You can also establish and change your passwords in this mode.

Setup mode can be a passcode protected mode. So after the initial configuration, you may need to enter the **HiPwd** to make changes in this mode. See “Password” on page 38.

— NOTE

If you lose your password, call the Invensys Foxboro for assistance.

If your transmitter is write protected, the display reads **Rd Only** if you try to enter Setup mode. In this case, you cannot enter Setup mode to make changes. You can, however, view but not edit the setup.

Upon attempts to enter this mode, you are asked, **Loop in Manual?** After placing the loop in manual, indicate 'yes' with the **Enter** key. This is also an off-line mode. Analog output is driven to 4 mA, pulse to 0.

The structural diagrams for the Setup mode begin on page 53.

Setting Fluid Parameters

The **2 Fluid** section of the Setup mode allows you to configure parameters for fluid type, fluid name (optional), temperature unit, flow temperature, density unit, flow density, base density, viscosity unit, and viscosity.

— NOTE —

If you are satisfied with the existing fluid parameters, do **not** enter the **3 New** parameter; doing so will reset all the other fluid parameters.

- ◆ In **3 New**, select the fluid as Liquid, Gas, or Steam to get the default data base for that medium. Refer to Tables 9, 10, and 11.
Selecting **3 Edit** enables you to edit the present fluid configuration.
- ◆ **FldTyp** shows the type of fluid presently configured.
- ◆ In **3 Name**, name the particular fluid (optional).
- ◆ In **3 TmpEGU**, select your choice of temperature unit (degF, degC, degR, or degK).
- ◆ In **3 FlwTmp**, enter the flow temperature in the temperature unit specified.
- ◆ In **3 DenEGU** select the density unit from the following picklist: kg/m³, lb/Yd³, lb/gal, oz/in³, lb/ft³, g/cm³, ST/Yd³, LT/Yd³, Custom.
If you pick Custom, you must define your custom unit. First, enter a **Label** for your custom unit using up to eight alphanumeric characters. Then, enter any **Offset** and a conversion factor (**Slope**) from kilograms per cubic meter to the custom unit.
- ◆ In **3 FlwDen**, enter the flow density in the density unit specified.
- ◆ In **3 BasDen**, enter the base density in the density unit specified.
- ◆ **LfciEGU** shows the units of the low flow cut-in.
- ◆ **Lfci** shows the Lfci presently configured.
- ◆ In **3 VisEGU**, select the viscosity unit (cPoise, Poise, cStoke, or PaSec).
- ◆ In **3 Visc**, enter the viscosity in the viscosity unit specified.

Setting Flow Parameters

The **2 Flow** section of the Setup mode allows you to configure parameters for flow.

In **3 FlwMap**, select **VolFlow**, **BVolFlow**, or **MassFlow**.

In **3 FlwEGU**, select the desired unit of flow from the picklist. If you pick **Custom**, you must define your custom unit. First, enter a **Label** for your custom units using up to eight

alphanumeric characters. Then, enter any offset (**Offset**) and a conversion factor (**Slope**) from kilograms per second (kg/s) for mass flow units or cubic meters per second (m³/s) for volume or base volume flow units to the custom units.

Example: The slope for a custom unit of yd³/min would be 78.47704 because $78.47704 \text{ yd}^3/\text{min} = 1 \text{ m}^3/\text{s}$.

In **3 FlwURV**, enter the upper range value in the flow unit just specified.

In **3 FlwDmp**, select the damping factor from the picklist.

In **3 VeIEGU**, select the desired velocity unit from the picklist.

Setting Tuning Parameters

The **2Tuning** section of the Setup mode allows you to specify several flowmeter options.

- ◆ In **3AddDrop**, configure the pulse compensation (signal conditioning) feature as **On** or **Off**.
- ◆ In **3 RdCorr**, configure the Reynolds number correction feature as **On** or **Off**.
- ◆ In **3 LFCI**, set the low flow cut-in parameter to the level above which the flowmeter begins to measure flow. Select an output that provides no output under no flow conditions. In **4 FlwEGU**, note the flow units in which the setting selections are shown. In **4 Setting**, select a setting from the picklist presented.

— NOTE —

The LFCI can be automatically set by the flowmeter in the Calibration/Test mode.

Setting Totals Parameters

The **2 Total** section of the Setup mode allows you to configure each of two totalizers. This is done in **3 TotNet** and **3 TotGrd**. For each totalizer:

- ◆ In **4 Map**, map the totalizer to **Volume**, **Mass**, or **BVolume**.
- ◆ In **4 EGU**, select the desired unit from the picklist presented.

If you pick **Custom**, you must define your custom unit. First, enter a **Label** for your custom units using up to eight alphanumeric characters. Then, enter any offset (**Offset**) and a conversion factor (**Slope**) from kilograms (for mass units) or cubic meters (for volume or base volume units) to the custom units.

Example: The slope for a custom unit of a 42 gallon barrel would be 6.2898 because $6.2898 \text{ bbl} = 1 \text{ m}^3$.

Setting Output Parameters

The **2 Output** section of the Setup mode allows you to configure the communications, mA output, pulse output, and display parameters.

Communications

There is no need to map the measurements to be displayed in the I/A Series system as they are already defined. The primary measurement is flow rate (volume, base volume, or mass); the secondary measurement is net total; the tertiary measurement is grand total.

In **3 Coms**, configure the communications parameters:

- ◆ In **4PolAddr**, specify the poll address from the picklist of numbers from 0 through 15.
- ◆ In **4Preambl**, set the number of preambles between 2 and 20.

mA Output

In **3 Fail**, configure the mA output to go fully downscale or upscale upon a failure.

Pulse Output (If pulse output specified)

In **3 Pulse**, go to **4 Pulse** and select the type of pulse output as **Rate**, **Total**, **Raw**, or **Off**.

If **Rate**, configure the following:

- ◆ In **4 Freq**, select the upper frequency end point corresponding to the highest frequency generated as 10, 100, or 1000 Hz.

If **Total**, configure the following:

- ◆ In **4 Pwidth**, select, the pulse width as 0.5, 5, or 50 ms.
- ◆ In **4 EGU**, select the units from the picklist provided.
- ◆ In **4 U/Pulse**, enter the units per pulse.

If **Raw**, no further action is required.

Display

Under **3Display**, configure the display parameters

Under **4 Show**, specify whether the reading is to be shown for each of the following measurements and, if shown, the **Format** (decimal point placement) of the displayed value:

- ◆ In **5 FlwVol**, the volume flow output display.
- ◆ In **5 TotNet**, the net totalizer reading.
- ◆ In **5 TotGrd**, the grand totalizer reading.

In **4 Show1st**, select the first measurement to be shown as FlwVol, Velcty, FlwBVo, FlwMas, or Raw.

In **4 Cycle**, specify whether the list of measurements configured to be shown are scanned automatically (Auto) or manually (Manual).

Setting Piping Parameters

The **2 Pipe** section of the Setup mode allows you to configure the parameters related to piping.

Piping

Under **3 Piping**, configure the parameters used by the flowmeter to correct for the effects of upstream piping and disturbances on the Flowing K-Factor as follows:

- ◆ In **4 Config**, select the upstream piping configuration from the following picklist (see Figure 30):
 - ◆ Straight
 - ◆ 1 EL PAR (1 elbow with shedder parallel to elbow plane)
 - ◆ 1 EL PER (1 elbow with shedder perpendicular to elbow plane)
 - ◆ 2L0PDPAR (2 elbows with shedder parallel to plane of closest elbow and distance to closest elbow is zero pipe diameters)
 - ◆ 2L0PDPER (2 elbows with shedder perpendicular to plane of closest elbow and distance to closest elbow is zero pipe diameters)
 - ◆ 2L5PDPAR (2 elbows with shedder parallel to plane of closest elbow and distance to closest elbow is 5 pipe diameters)
 - ◆ 2L5PDPER (2 elbows with shedder parallel to plane of closest elbow and distance to closest elbow is 5 pipe diameters)
 - ◆ Reducer
- ◆ In **4 UpDist**, enter the distance to the first upstream flow disturbance in pipe diameters.

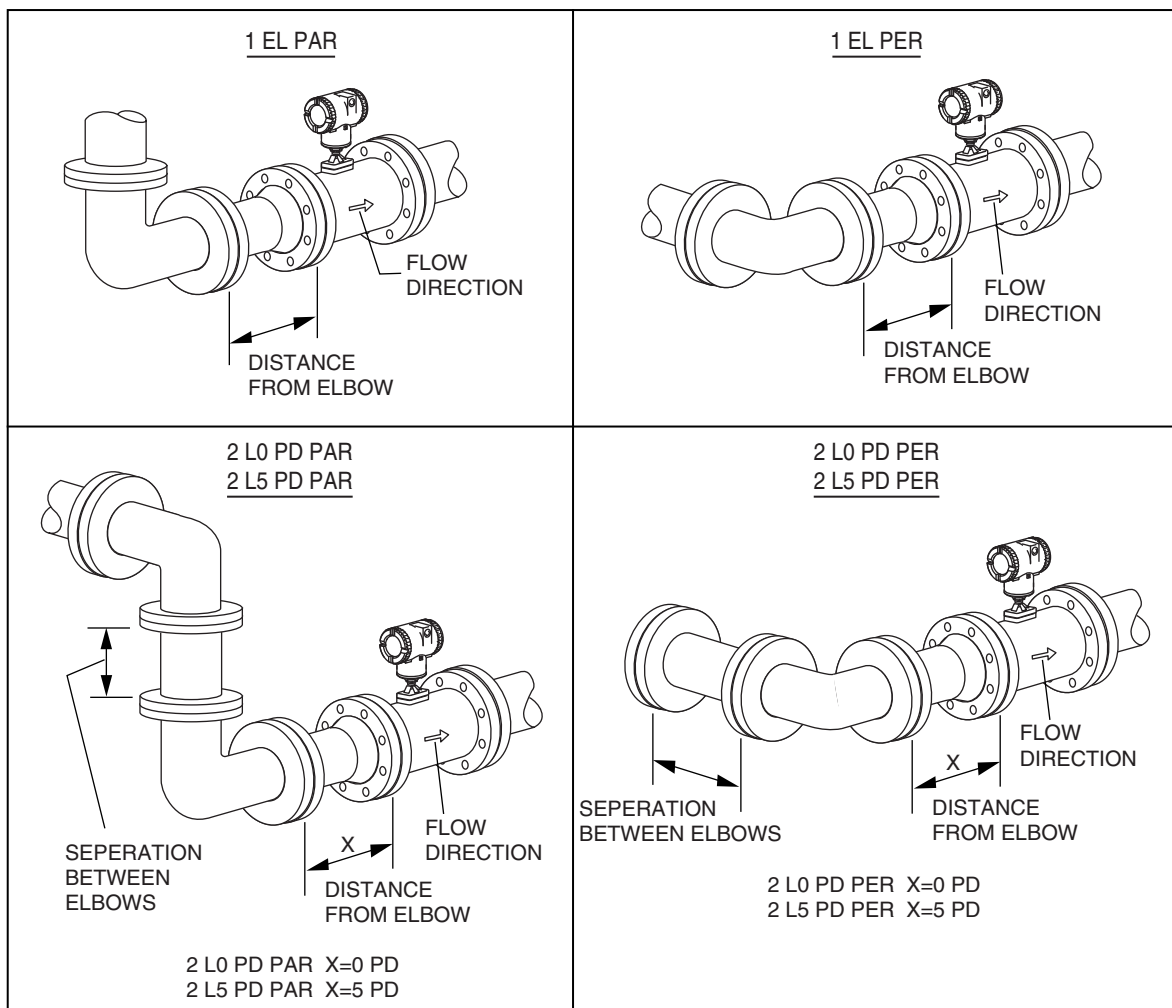

Figure 30. Piping Configurations

Pipe Bore

In **3 BorSch**, select the pipe bore from the following picklist: Sched 10, Sched 40, Sched 80, PN16, PN40, PN64, PN100, or Sanitary.

Setting Tag Parameters

The **2 Tags** section of the Setup mode allows you to configure the following identification parameters:

- ◆ In **3 HrtDes**, enter the device description.
- ◆ In **3 HrtTag**, enter an alphanumeric description if desired.

Setting Flowtube Parameters

The **2 NewTube** section of the Setup mode allows you to configure the following flowtube parameters:

Model

In **3 Model**, enter the model number of the flowtube (16 characters maximum) as found on the flowmeter tag. It is already in the database if the flowtube and electronics were shipped as a unit.

Special Flowtube

If your flowtube was customized to be different from the model number entered, you can override certain descriptions in the model code in **3 Special** as follows:

- ◆ In **4 TubDia**, enter the custom flowtube diameter in meters
- ◆ In **4 TubAlp** enter the thermal coefficient of expansion (alpha) in $m/m^{\circ}K$
- ◆ In **4 LfUFac** enter the low flow cut-in user factor.

Reference Number

In **3 Ref No**, enter the reference number (serial number) of the flowtube (16 characters maximum) as found on the flowmeter tag. It is already in the database if the flowtube and electronics were shipped as a unit.

K-Factor

In **3 K Ref**, enter the k-factor as follows:

- ◆ In **4 K EGU**, select p/l or p/ft³ as the unit of the k-factor.
- ◆ In **4 K Ref**, enter the reference K-factor as found on the flowmeter tag.

Changing the Password

The **2 Passwd** section of the Setup mode allows you to create or change the passwords.

In **4 LoPwd**, enter the new password for access to clear (reset) the net and pulse totalizers.

In **4 HiPwd**, enter the new password for access to all modes.

NOTE

1. Passwords contain four characters.
 2. Use four spaces to configure 'No Password'.
-

Setup Menu Tree

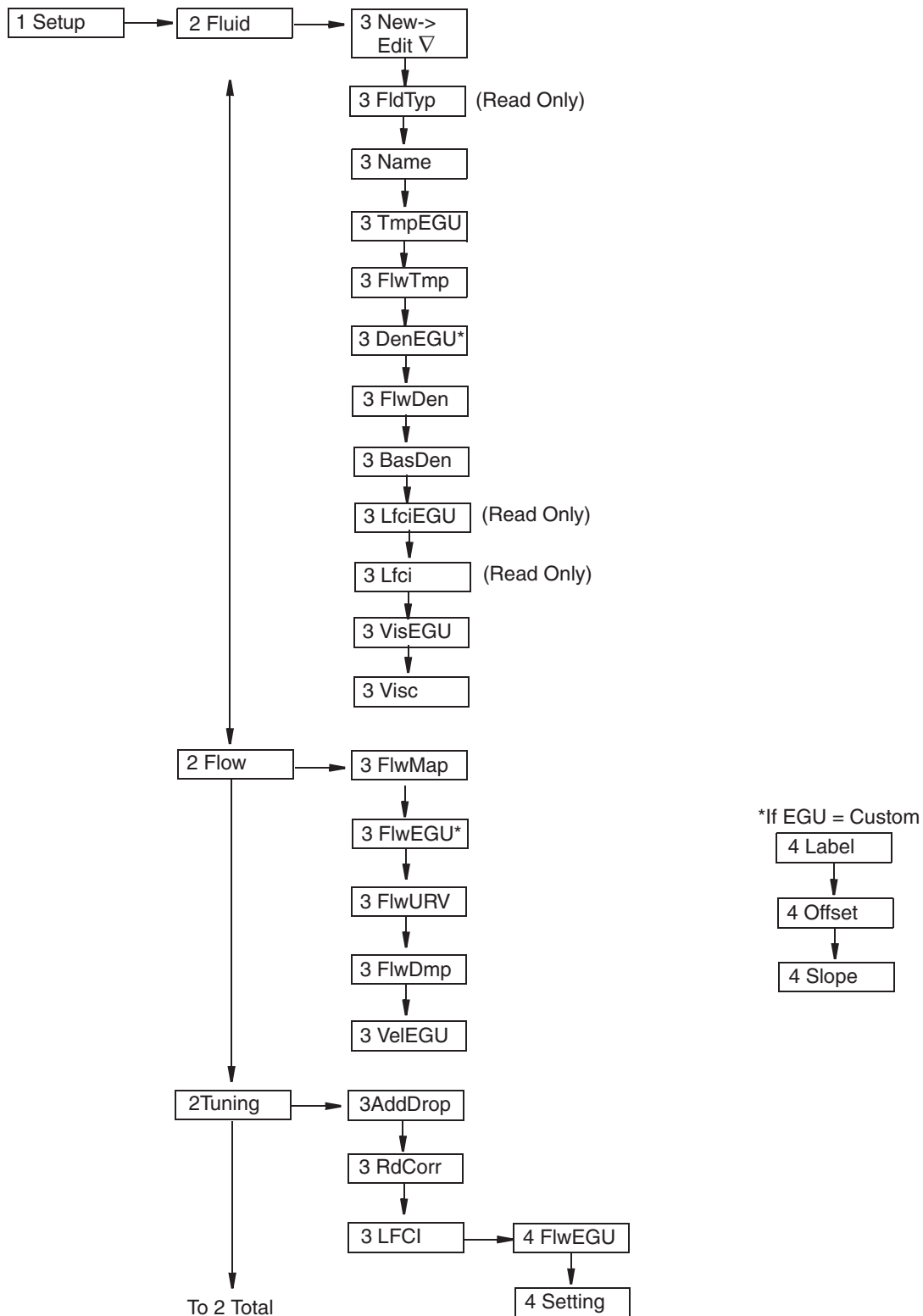

Figure 31. Setup Menu Tree (1 of 3)

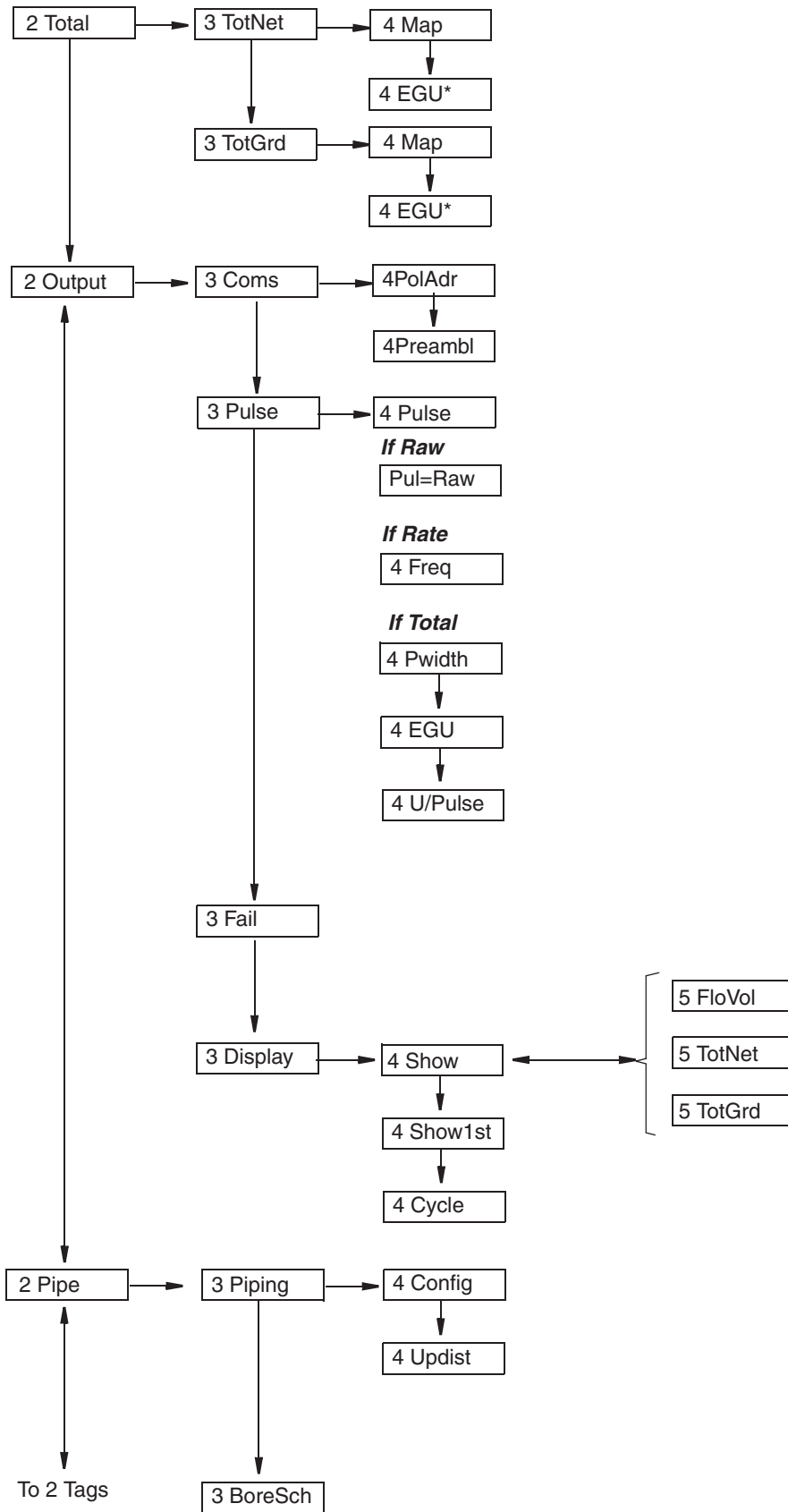

Figure 32. Setup Menu Tree (2 of 3)

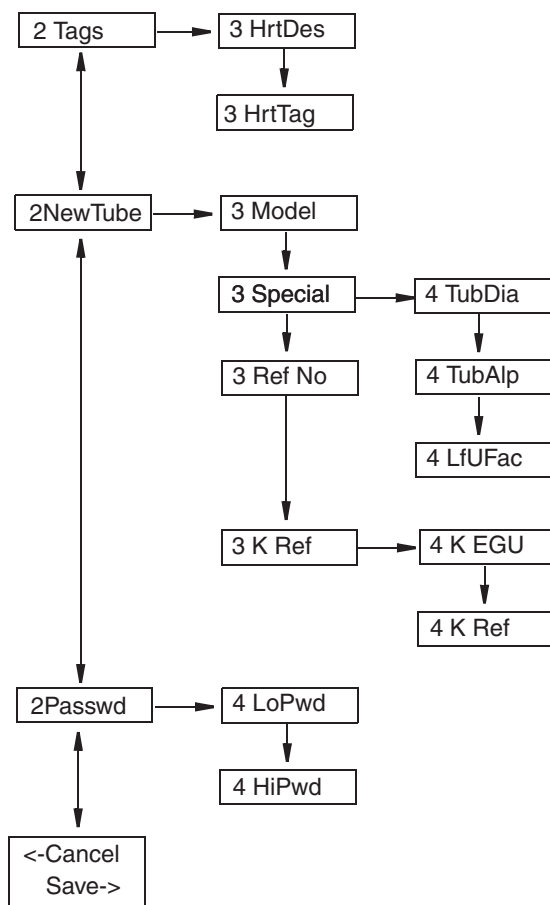

Figure 33. Setup Menu Tree (3 of 3)

Calibration/Test Mode

The Calibration/Test mode enables you to:

- ◆ Set the Low Flow Cut In (LFCI)
- ◆ Calibrate the 4 and 20 mA output
- ◆ Self test the flowmeter
- ◆ Use the flowmeter to test the loop.

The Calibration/Test mode can be a passcode protected mode. So after the initial configuration, you may need to enter the **HiPwd** to perform the procedures in this mode. See “Password” on page 38.

— NOTE

If you lose your password, call the Invensys Foxboro for assistance.

The structural diagram for the Calibration/Test mode is shown in Figure 34.

Calibration

In **2 Calib**, go to **3 SetLFCI** to have the flowmeter automatically set the Low Flow Cut-In. In doing this, the flowmeter chooses the lowest level at which no signal is detected over a 20-second time interval. It is important that the flow be zero during this procedure.

— NOTE —

This procedure may confirm your choice of LFCI setting in “Setting Tuning Parameters” on page 48. However, if it picks a different selection, it overwrites your selection.

In **2 Calib**, go to **3 Cal mA** to calibrate the 4 and 20 mA output.

- ◆ The **4Restore** parameter restores the factory calibration.
- ◆ The **4Cal 4mA** and **4Cal20mA** parameters allow the 4 to 20 mA output of the flowmeter to be calibrated or matched to the calibration of the receiving device to an accuracy of 0.005 mA.

— NOTE —

The flowmeter has been accurately calibrated at the factory. Recalibration of the output is normally **not** required, unless it is being adjusted to match the calibration of the receiving device.

- ◆ In **4CalDate**, enter the date of the last calibration if desired.
- ◆ In **4Initial**, enter the initials of the last calibrator if desired.

Test

In **2 Test**, you can self test the flowmeter and use the flowmeter to test the loop.

Testing the Loop

The flowmeter can also be used as a signal source to check and/or calibrate other instruments in the control loop, such as indicators, controllers, and recorders. To do this, set the mA output (**3 Set mA**), rate pulse output (**3 Set Hz**), or digital output (**3 SetDig**) signals to any value within the range limits of the meter.

Testing the Flowmeter

The self test parameter (**3SelfTst**) checks the flowmeter operation by injecting, near the front end of the electronics, an internally generated periodic signal of known frequency. The frequency of this signal is in turn measured and checked against the injected signal.

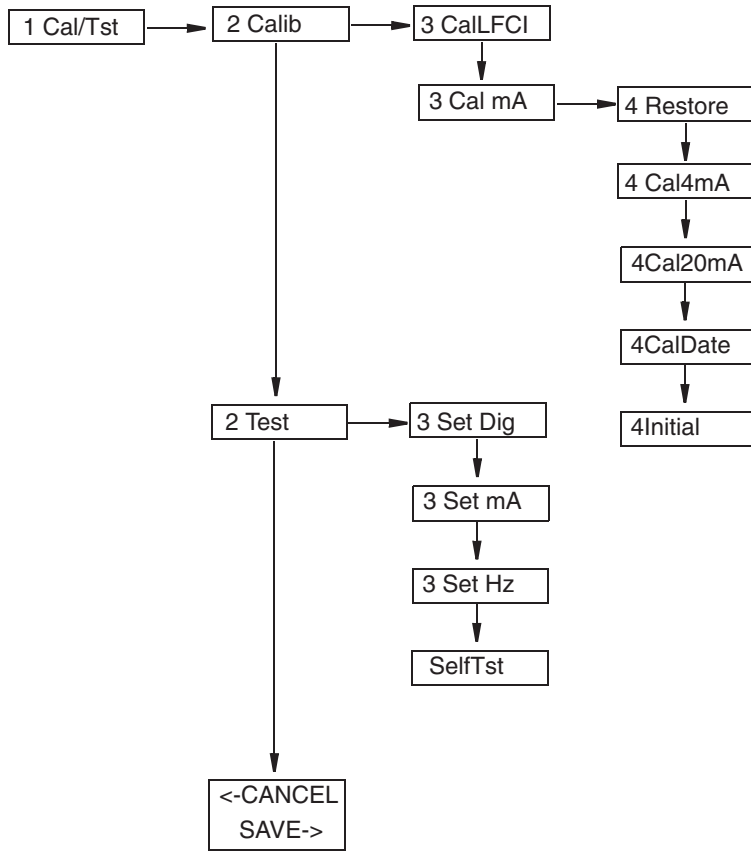

Figure 34. Calibration/Test Menu Tree

Error Messages

Operation Error Messages

This section defines error messages that may be displayed and actions that can be taken to correct the error. Some messages appear periodically while seeing a valid flow measurement. This typically occurs when 'soft' limits have been exceeded and the flowmeter is warning that a hard limit is approaching.

Table 12. Operation Error Messages

Message	Explanation	Corrective Action
Override	The flowmeter is being overridden by an external host such as another configurator or control system.	None - This is an awareness message that the flowmeter is being overridden
W: Input xxxxxxx	Warning: An input to a specific measurement or calculation has exceeded the normal limit and is in the 'soft limit' region. The measurement or calculation is defined on the second line of the message.	1. Check inputted temperature flowing temperature to make sure it is within the temperature limits of the sensor. 2. Check the raw frequency to determine if it is out of limits for the flowmeter size.
B: Input xxxxxxx	Bad Input: Same as above except the inputs have now exceeded the 'soft' limit. This adversely affects all measurements.	Same as above.
W: Input Total	Warning: The total (pulse, net, or grand) may not be correct due to a momentary loss of power.	Clear the total. Pulse and Net total can be cleared independently. Clearing the grand total clears pulse and net totals also.
FcErr E:0x####	An internal function did not execute successfully.	If this occurs at startup, an invalid configuration exists. Recheck the configuration. If this does not resolve the problem, re-enter the Model.

Configuration Error Messages

Table 13. Configuration Error Messages

Message	Explanation	Corrective Action
WrProtct	The write protect jumper is in the 'protect' position or is missing. The configuration cannot be changed unless the jumper is in the 'write' position.	Install or move the write protect jumper to the 'write' position. See "Setting the Write Protect Jumper" on page 25.
Cfg Err MsCode	An incorrect model code has been entered.	Enter the correct model code.

Table 13. Configuration Error Messages

Message	Explanation	Corrective Action
No Pulse Hardware	An incorrect model code has been entered. The model code entered was for a flowmeter with a pulse output. The electronics module does not have a pulse output PWB.	Enter the correct model code which begins with 84F-E, 84W-E, 84F-U, or 84W-U.
Bad URV URV=URL	The entered URV has exceeded the URL (meter capacity) of the flowmeter.	Press Enter to change the URV to the value of the URL. Make sure that the entered value for Flowing Density is correct.
Bad URV URV=Min	The entered URV is less than the minimum value allowed for the URV.	Press Enter to change the URV to the minimum value allowed. Make sure that the entered value for Flowing Density is correct. Note: Changing the LFCI (low flow cut-in) can affect the minimum allowable URV.
FcErr E:0x####	An internal function did not execute successfully.	Review the inputs associated with the last menu function. If this does not resolve the problem, re-enter the Model.

4. Operation Via HART Communicator

Online Menu

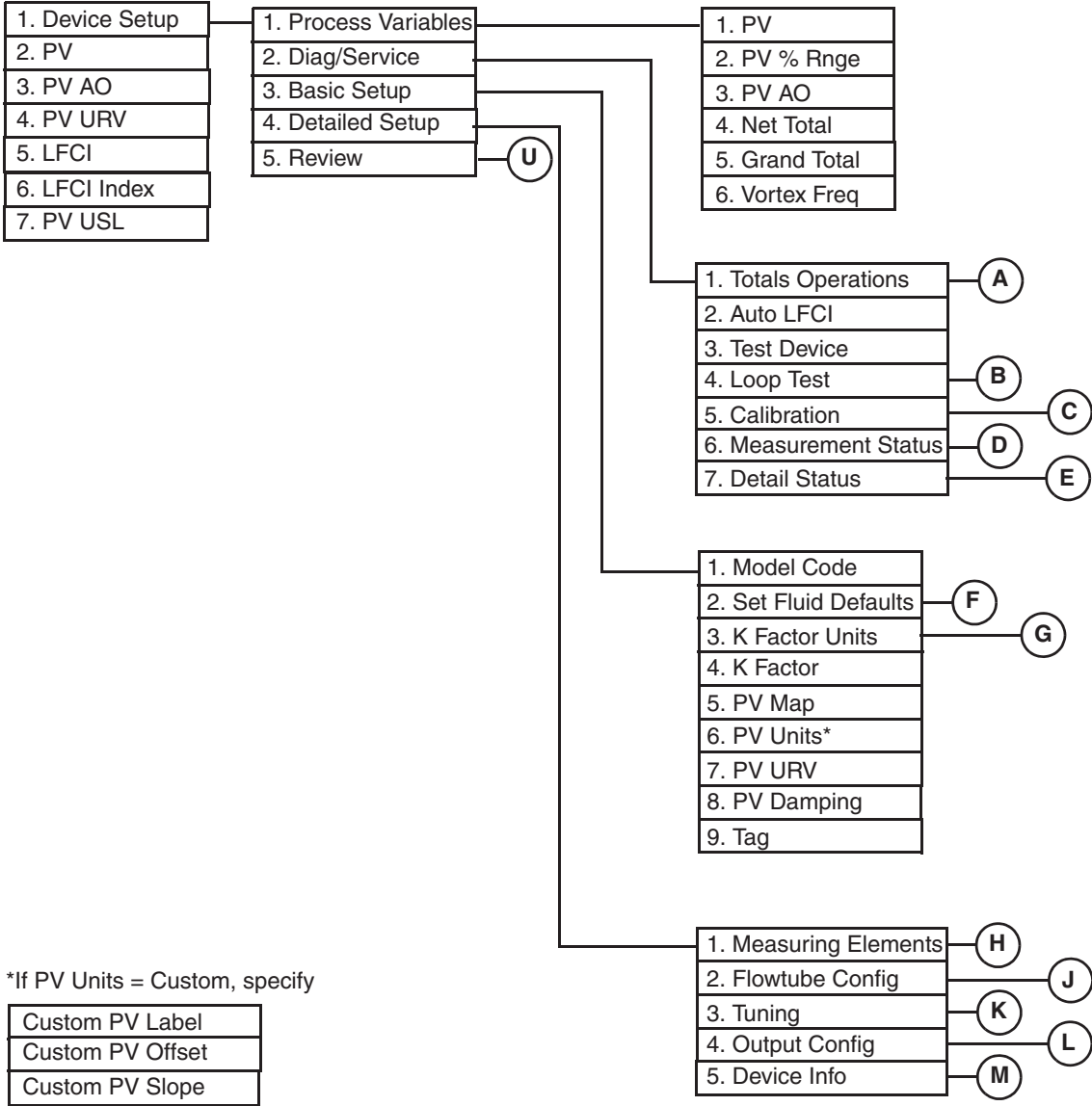

Figure 35. 84 Vortex Flowmeter Online Menu Tree (1 of 4)

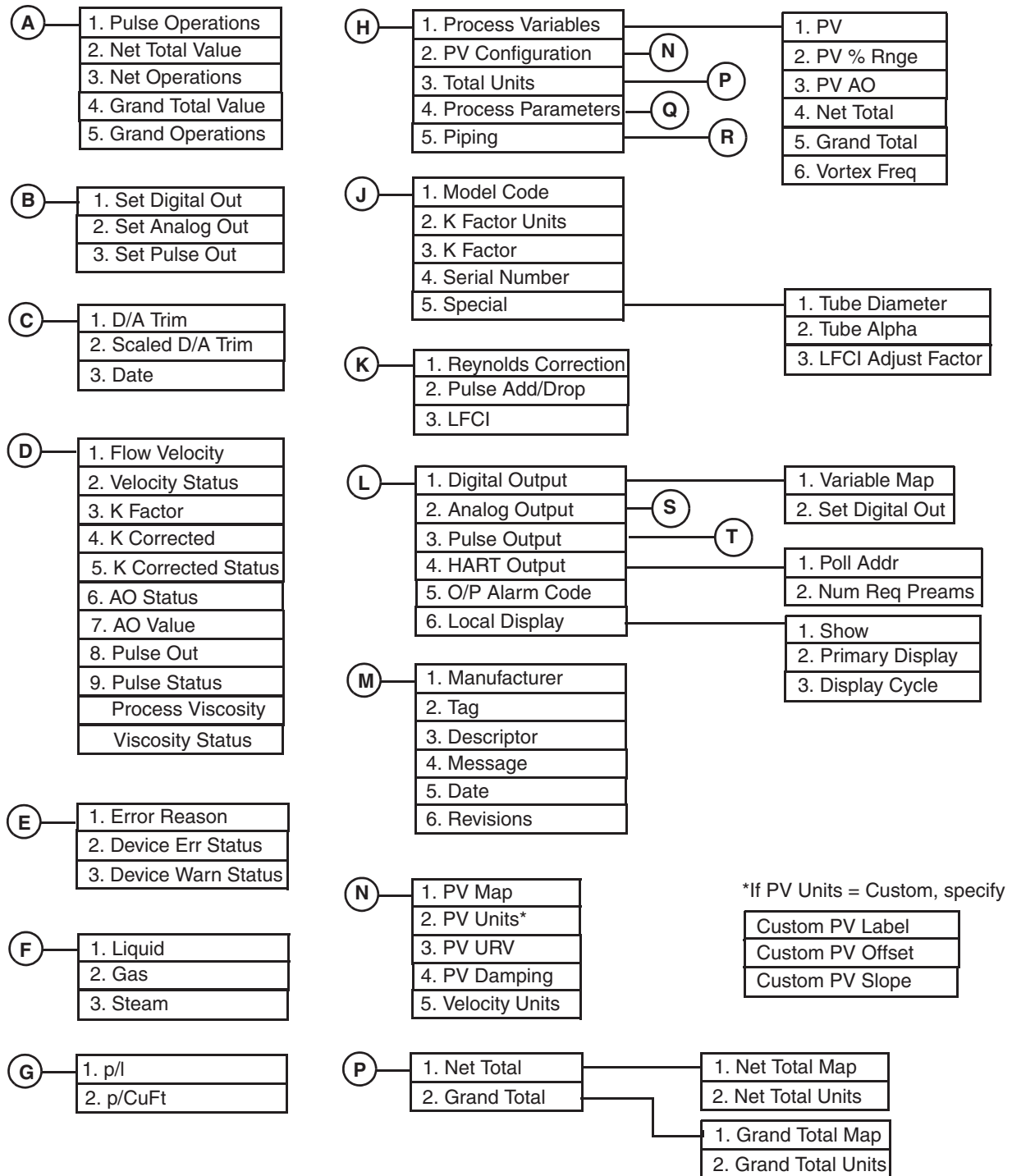

Figure 36. 84 Vortex Flowmeter Online Menu Tree (2 of 4)

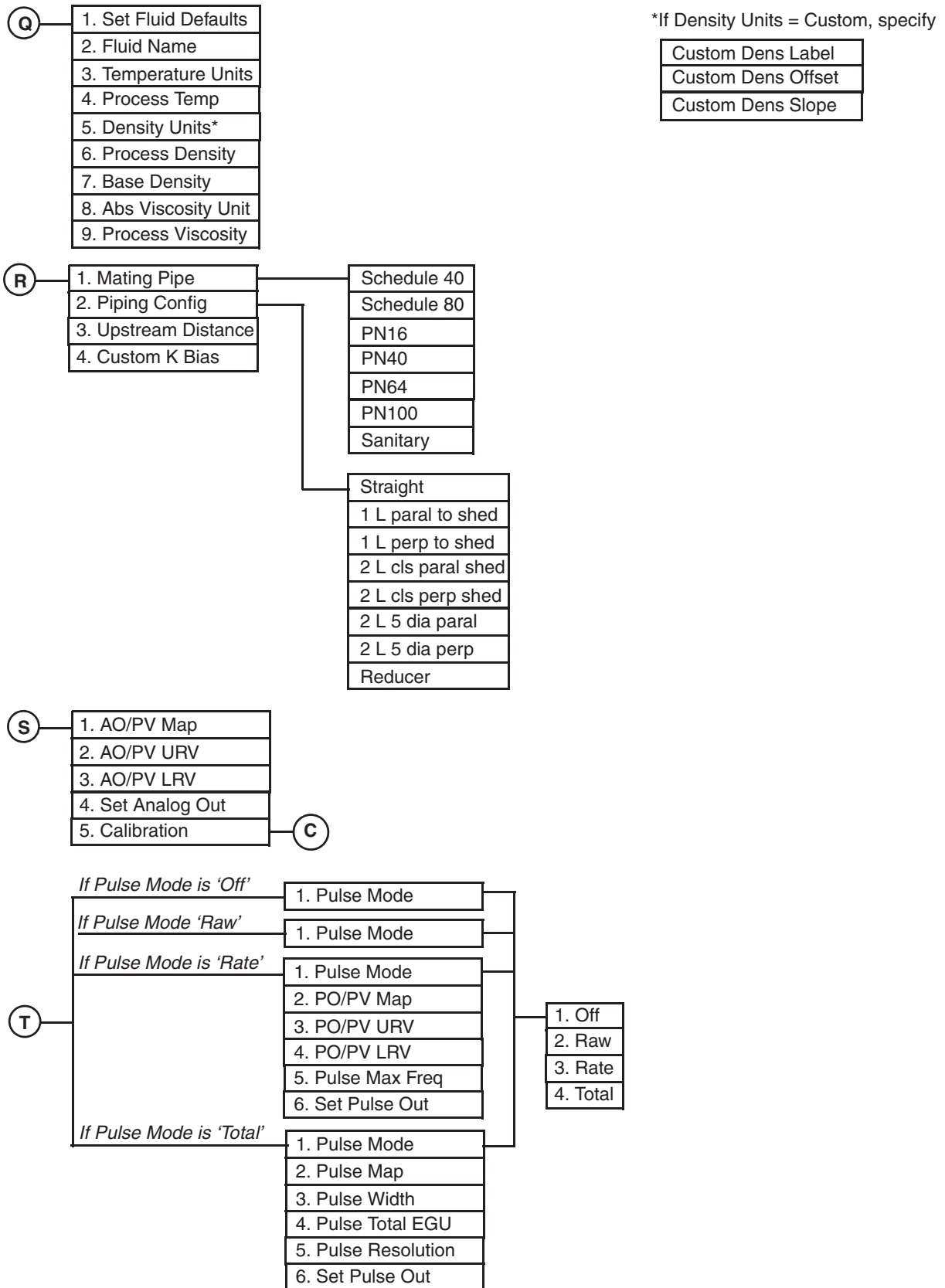
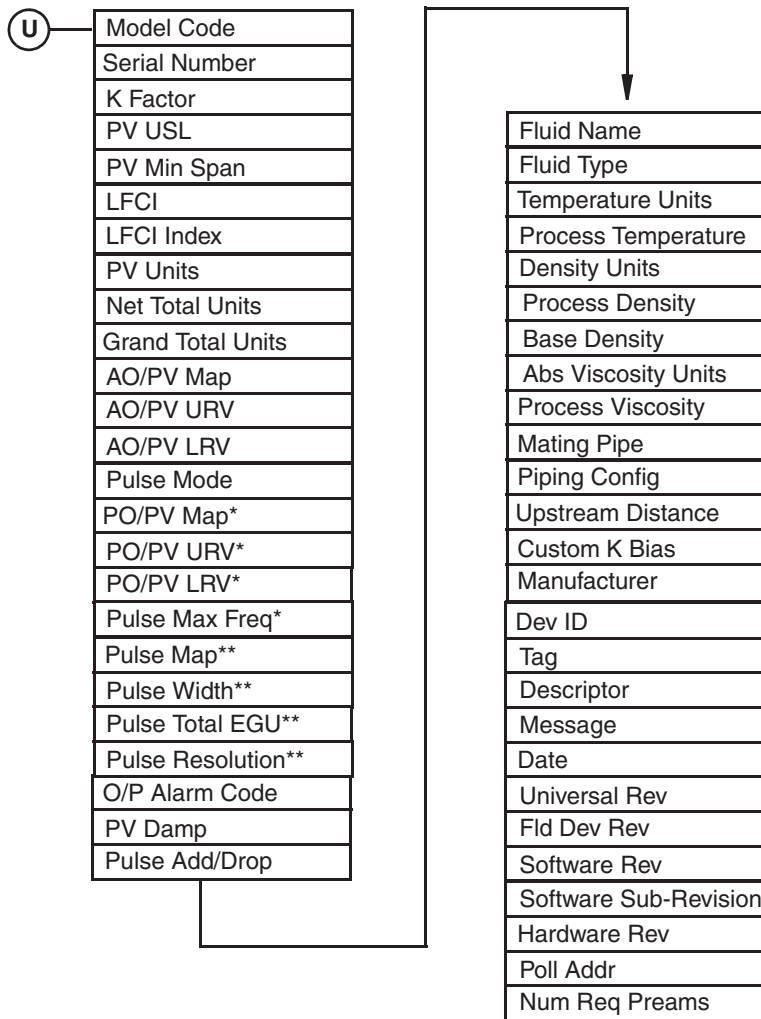

Figure 37. 84 Vortex Flowmeter Online Menu Tree (3 of 4)



* If Pulse mode = Rate
 ** If Pulse Mode = Total

Figure 38. 84 Vortex Flowmeter Online Menu Tree (4 of 4)

Explanation of Parameters

Parameter	Fast-Key Path	Explanation
Abs Viscosity Unit	1,4,1,4,8	Select the viscosity unit from the picklist provided.
Abs Viscosity Units	1,5	Shows the absolute viscosity unit.
Analog Output	1,4,4,2	Path to configuring the analog output.
AO Status	1,2,6,6	Shows the AO status.
AO Value	1,2,6,7	Shows the AO value
AO/PV LRV	1,4,4,2,3 1,5	Shows the AO/PV LRV.
AO/PV Map	1,4,4,2,1 1,5	Shows whether the PV is mapped to Volume Flow, Mass Flow, BVolFlow, or Velocity.
AO/PV URV	1,4,4,2,2 1,5	Shows the AO/PV URV.
Auto LFCI	1,2,2	Procedure for the flowmeter to automatically set the LFCI.
Base Density	1,4,1,4,7 1,5	In Detailed Setup, enter the base density in the density unit specified. This is only used to calculate the base volumes. In Review, shows the base density.
Basic Setup	1,3	Path to basic setup parameters.
Calibration	1,2,5 1,4,4,2,5	Path to performing a D/A trim or scaled D/A trim.
Custom K Bias	1,4,1,5,4 1,5	In Detailed Setup, enter the custom K-factor (with sign in percent). In Review, shows the custom K-Factor.
Custom Dens Label	1,4,1,4,5	Enter the label for your custom density unit.
Custom Dens Offset	1,4,1,4,5	Enter any offset.
Custom Dens Slope	1,4,1,4,5	Enter a conversion factor for the custom density unit.
Custom PV Label	1,3,6 1,4,1,2,2	Enter the label for your custom PV unit.
Custom PV Offset	1,3,6 1,4,1,2,2	Enter any offset.
Custom PV Slope	1,3,6 1,4,1,2,2	Enter a conversion factor for the custom PV unit.
D/A Trim	1,2,5,1 1,4,4,2,5,1	Procedure to trim the 4 and 20 mA output values of the flowmeter to match the output of a plant standard measurement device.
Date	1,2,5,3 1,4,5,5 1,4,4,2,5,3 1,5	In Diag/Service, enter the date of the last calibration. In Detailed Setup, enter the date of the last calibration. In Review, shows the last calibration date.
Date	1,4,5,5 1,4,4,2,5,3	Enter the date of the last calibration (mm/dd/yyyy).

Parameter	Fast-Key Path	Explanation
Density Units	1,4,1,4,5 1,5	In Detailed Setup, select the density unit from the picklist provided. In Review, shows the density units.
Descriptor	1,4,5,3 1,5	In Detailed Setup, enter the descriptor (16 characters maximum). In Review shows the descriptor.
Detailed Setup	1,4	Path to detailed setup parameters.
Detail Status	1,2,7	Path to viewing the status of various device parameters.
Device Err Status	1,2,7,2	Shows the device error status.
Dev ID	1,5	Shows the device identification number.
Device Info	1,4,5	Path to configuring the device description parameters.
Device Setup		Path to all other parameters.
Device Warn Status	1,2,7,3	Shows the device warning status.
Diag/Service	1,2	Path to status, test, and calibration parameters.
Digital Output	1,4,4,1	Path to configuring the digital output.
Display Cycle	1,4,4,6,3	Specify whether the list of measurements configured to be displayed are scanned automatically or manually.
Error Reason	1,2,7,1	Shows the error reason code.
Fld Dev Rev	1,5	Shows the software version of the vortex flowmeter.
Flow Velocity	1,2,6,1	Shows the flow velocity value.
Flowtube Configuration	1,4,2	Path to configuring the flowtube parameters.
Fluid Name	1,4,1,4,2 1,5	In Detailed Setup, enter the name of the fluid. In Review, shows the fluid name.
Fluid Type	1,5	Shows the fluid type.
Grand Operations	1,2,1,4	Procedure to start, pause or clear the grand total.
Grand Total	1,1,5 1,4,1,1,5 1,4,1,3,2	In Process Variables, shows the grand total. In Detailed Setup, path to configuring the grand total mapping and units.
Grand Total Map	1,4,1,3,2,1	Map the Grand Total to Volume, Mass, or BVolume.
Grand Total Units	1,4,1,3,2,2 1,5	In Detailed Setup, select the grand total units from the picklist provided. In Review, shows the grand total units.
Grand Total Value	1,2,1,3	Shows the grand total value.
Hardware Rev	1,5	Shows the vortex flowmeter hardware revision level.
HART Output	1,4,4,4	Path to configuring the HART output.
K Corrected	1,2,6,4	Shows the K Corrected value.
K Corrected Status	1,2,6,5	Shows the K Corrected status
K Factor	1,2,6,3 1,3,4 1,4,2,3 1,5	In Diag/Service, shows the K-Factor value. In Basic Setup, enter the K-Factor. In Detailed Setup, enter the K-Factor. In Review, shows the K-Factor.
K Factor Units	1,3,3 1,4,2,2	In Basic Setup, path to selecting the K-Factor unit. In Detailed Setup, path to selecting the K-Factor unit.

Parameter	Fast-Key Path	Explanation
LFCI	5 1,4,3,3 1,5	In the Main Menu, shows the low flow cut-in value. In Detailed Setup, confirm or change the LFCI. In Review, shows the LFCI.
LFCI Index	6 1,5	Shows the low flow cut-in picklist number.
LFCI Adjust Factor	1,4,2,5,3	Enter the low flow cut-in user factor.
Local Display	1,4,4,6	Path to configuring the local display.
Loop Test	1,2,4	Procedure to use the flowmeter as a calibration source to check other instruments in the loop.
Manufacturer	1,4,5,1 1,5	Shows the manufacturer as Foxboro.
Mating Pipe	1,4,1,5,1 1,5	In Detailed Setup, select the type of mating pipe from the picklist provided. In Review, shows the type of mating pipe.
Measurement Status	1,2,6	Path to viewing the status of various measurement parameters.
Measuring Elements	1,4,1	Path to configuring the measuring element parameters.
Message	1,4,5,4 1,5	In Detailed Setup, enter the message (32 characters max). In Review shows the message.
Model Code	1,3,1 1,4,2,1 1,5	In Basic Setup, enter the model code. In Detailed Setup, enter the model code. In Review, shows the model code.
Net Operations	1,2,1,2	Procedure to start, pause or clear the net total.
Net Total	1,1,4 1,4,1,1,4 1,4,1,3,1	In Process Variables, shows the net total. In Process Variables, shows the net total. In Detailed Setup, path to configuring the net total mapping and units.
Net Total Map	1,4,1,3,1,1	Map the Net Total to Volume, Mass, or BVolume.
Net Total Units	1,4,1,3,1,2 1,5	In Detailed Setup, select the net total units from the picklist provided. In Review, shows the net total units.
Net Total Value	1,2,1,1	Shows the net total value.
Num Req Preams	1,4,4,4,2 1,5	In Detailed Setup, configure the number of preambles to be sent in a response message from the flowmeter to the host. In Review, shows the number of preambles.
O/P Alarm Code	1,4,4,5 1,5	In Detailed Setup, configure the output to go fully upscale or downscale if a failure occurs. In Review, shows the O/P Alarm Code.
Output Configuration	1,4,4	Path to configuring the output parameters.
p/CuFt	1,3,3,2	Sets the K-Factor unit to pulses per cubic foot.
p/l	1,3,3,1	Sets the K-Factor unit to pulses per liter.
Piping	1,4,1,5	Path to configuring the piping parameters.

Parameter	Fast-Key Path	Explanation
Piping Config	1,4,1,5,2 1,5	In Detailed Setup, select the type of piping configuration from the picklist provided. In Review shows the type of piping configuration.
PO/PV LRV	1,4,4,3,4 1,5	Shows the PO/PV LRV.
PO/PV Map	1,4,4,3,2 1,5	Shows whether the PV is mapped to Volume Flow, Mass Flow, BVolFlow, or Velocity.
PO/PV URV	1,4,4,3,3 1,5	Shows the PO/PV URV.
Poll Addr	1,4,4,4,1 1,5	In Detailed Setup, configure the poll address to a number from 0 through 15. A nonzero number applies to multidrop applications. In Review, shows the poll address.
Primary Display	1,4,4,6,2	Select the first measurement to be displayed.
Process Density	1,4,1,4,6 1,5	In Detailed Setup, enter the flow density in the density unit specified. In Review, shows the process density.
Process Parameters	1,4,1,4	Path to configuring the process parameters.
Process Temperature	1,4,1,4,4 1,5	In Detailed Setup, enter the flow temperature in the temperature unit specified. In Review, shows the process temperature.
Process Variables	1,1 1,4,1,1	Path to viewing the process variable values.
Process Viscosity	1,2,6 1,4,1,4,9 1,5	In Diag/Service, shows the process viscosity value. In Detailed Setup, enter the base viscosity in the viscosity unit specified. In Review, shows the process viscosity.
Pulse Add Drop	1,4,3,2 1,5	In Detailed Setup, configure the pulse compensation (signal conditioning) feature On or Off. In Review, shows the pulse compensation as On or Off.
Pulse Map	1,4,4,3,2 1,5	Shows whether the pulse is mapped to Volume Flow, Mass Flow, BVolFlow, or Velocity.
Pulse Max Freq	1,4,4,3,5 1,5	In Detailed Setup, set the upper frequency end point corresponding to the highest frequency as 10, 100, or 1000 Hz. In Review, shows the pulse maximum frequency.
Pulse Mode	1,4,4,3,1 1,5	In Detailed Setup, select the type of pulse output as Rate, Total, Raw, or Off. In Review, shows the type of pulse output.
Pulse Operations	1,2,1,1	Procedure to start, pause or clear the pulse total.
Pulse Out	1,2,6,8	Shows the pulse value.
Pulse Output	1,4,4,3	Path to configuring the pulse output.
Pulse Resolution	1,4,4,3,5	Enter the units per pulse.
Pulse Status	1,2,6,9	Shows the pulse status.
Pulse Total EGU	1,4,4,3,4	Select the unit from the picklist provided.

Parameter	Fast-Key Path	Explanation
Pulse Width	1,4,4,3,3	Select the pulse width as 0.5, 5, or 50 ms.
PV	2 1,1,1 1,4,1,1,1	Shows the value of the process variable.
PV % Rnge	1,1,2 1,4,1,1,2	Shows the process variable in percent of range.
PV AO	3 1,1,3 1,4,1,1,3	Shows the analog output of the process variable.
PV Configuration	1,4,1,2	Path to configuring the PV parameters.
PV Damp	1,5	Shows the damping time.
PV Damping	1,3,8 1,4,1,2,4	Enter the damping time if different than the one shown.
PV Map	1,3,5 1,4,1,2,1	Map the PV to Volume Flow, Mass Flow, BVolFlow, or Velocity.
PV Min Span	1,5	Shows the minimum span.
PV Units	1,3,6 1,4,1,2,2 1,5	In Basic Setup, select the PV units from the picklist. In Detailed Setup, select the PV units from the picklist. In Review, shows the PV units.
PV URV	4 1,3,7 1,4,1,2,3	In the Basic Menu, shows the process variable upper range value. In Basic Setup, enter the PV URV. In Detailed Setup, enter the PV URV.
PV USL	7 1,5	In the Basic Menu, shows the upper sensor limit. In Review, shows the upper sensor limit.
Review	1,5	Path to viewing flowmeter values and settings.
Revisions	1,4,5,6	Path to configuring the various revision levels.
Reynolds Number	1,4,3,1	Configure the Reynolds Number correction feature On or Off.
Scaled D/A Trim	1,2,5,2 1,4,4,2,5,2	Procedure to trim the low and high mA output values of the flowmeter to match the output of a plant standard measurement device.
Serial Number	1,4,2,4 1,5	In Detailed Setup, enter the serial number. In Review, shows the serial number.
Set Analog Out	1,2,4,2 1,4,4,2,4	Procedure to set the analog output to 4 mA, 20 mA, or another value.
Set Digital Out	1,2,4,1 1,4,4,1,2	Procedure to set the digital output to override the PV, net total, grand total, or vortex frequency.
Set Fluid Defaults	1,3,2 1,4,1,4,1	Path to setting the default parameters for the type of fluid selected (liquid, gas, or steam).
Set Pulse Out	1,2,4,3 1,4,4,3,6	Procedure to set the pulse output to 0 Hz, the maximum frequency, or another value.
Show	1,4,4,6,1	Specify which measurements are to be displayed and their format (decimal point placement).
Software Rev	1,5	Shows the software revision level.

Parameter	Fast-Key Path	Explanation
Software Sub-Revision	1,5	Shows the software sub-revision level.
Special	1,4,2,5	Path to configuring special flowtube parameters.
Tag	1,3,9 1,4,5,2 1,5	In Basic Setup, enter the tag (8 characters maximum). In Detailed Setup, enter the tag (8 characters maximum). In Review, shows the tag.
Temperature Units	1,4,1,4,3 1,5	In Detailed Setup, select the temperature unit from the picklist provided. In Review, shows the temperature units.
Test Device	1,2,3	Procedure to self test the device.
Total Units	1,4,1,3	Path to configuring the totals parameters.
Totals Operations	1,2,1	Path to viewing, starting, stopping, or clearing the totalizers.
Tube Alpha	1,4,2,5,2	Enter the thermal coefficient of expansion (alpha) in m/m/°K.
Tube Diameter	1,4,2,5,1	Enter the custom flowtube diameters in meters.
Tuning	1,4,3	Path to configuring the tuning parameters.
Universal Rev	1,5	Shows the universal command set revision level.
Upstream Distance	1,4,1,5,3 1,5	In Detailed Setup, enter the distance to the first upstream disturbance in pipe diameters. In Review, shows the upstream distance.
Variable Map	1,4,4,1,1	Map the output as the primary, secondary, tertiary, or fourth output.
Velocity Status	1,2,6,2	Shows the flow velocity status.
Velocity Units	1,4,1,2,5	In Detailed Setup, select the unit from the picklist.
Viscosity Status	1,2,6	Shows the process viscosity status.
Vortex Freq	1,1,6 1,4,1,1,6	Shows the vortex frequency.

5. Troubleshooting

—  **CAUTION** —

Components in your flowmeter are ESD sensitive and thus are susceptible to damage resulting from electrostatic discharge. Invensys Foxboro recommends that you be grounded via a conductive wrist strap or by standing on an ESD mat when performing maintenance in the electronics compartment or the remote junction box, and if the housing is removed.

— **NOTE** —

Before troubleshooting your vortex flowmeter, verify that the flowmeter has been correctly configured for the model, flow, and output parameters.

Flowmeter Output Indicates Flow When There Is No Flow

In some installations, the flowmeter can indicate flow when the line is shut down. This could be the effect of a leaking valve, sloshing fluid, or noise sources such as pump-induced pipe vibration.

1. Check the Low Flow Cut-In (LFCI) setting.

The LFCI setting sets the sensitivity of the electronics to the sensor output signal. There are eight LFCI settings. The default setting leaving the factory is level 4 and is suitable for most applications. Should there be excessive vibration, resulting in false excitation of the vortex sensor, it may be necessary to increase the LFCI setting. To set the LFCI:

- a. Make sure there is a no-flow condition. Preferably block valves should be closed. Control valves can leak when closed, resulting in some flow through the flowmeter that it can detect.

— **NOTE** —

Setting the dampening to 0 seconds will show the magnitude of any false excitation.)

- b. Increase the LFCI setting by one level and observe the signal output. The LFCI should be increased until there is no false signal. Alternately, the **AUTO LFCI** command can be used. When this command is executed, the flowmeter starts at the most sensitive LFCI setting. If false signal is detected within a 20 second period, the LFCI is increased to the next level and so on until a level is reached where there is no false signal after a 20 second time period.
 - c. If dampening was changed to 0 seconds, change dampening to a desired level.
 - d. If the LFCI level has changed, make sure controllers and receivers can accommodate the increased LFCI setting. Output remains at 4 mA from zero flow until this flow rate is reached.
2. If the LFCI is higher than desired, there are several possible causes:

- a. Check the flowmeter sizing. The flowmeter could be over-sized for the application, resulting in the need to provide a measurement at a very low flow velocity. Consult FlowExpertPro™ to validate the meter sizing.
 - b. Check for excessive vibration in a plane that is parallel to the vortex sensor. The vortex sensor axis is perpendicular to the pipe diameter. See Figure 9. For most applications where the electronics are top mounted and the pipe is supported by horizontal pipe supports, this may result in false signal. In these cases, reposition the meter so the electronics are pointed to the side. The sensor axis will then be vertical.
 - c. Examine peripheral equipment and vibration sources to assure they are not imparting vibration into the vortex flowmeter.
3. Other sources of false signal:
- a. Check for 60 Hz signal pickup. Check the output of the flowmeter against the expected value for a 60 Hz input signal. If 60 Hz interference is present, examine the flowmeter and interconnecting wiring for proper grounding and shielding.
 - b. If the flowmeter is remote mounted, check to see that the remote cable is properly terminated. The cable was properly terminated at the factory, but in cases where the cable was shortened (only shorten the cable at the flowtube end), check the termination (see “Electrical Installation” on page 25).

Flowmeter Has No Output (No mA Output and the Display [If So Equipped] Is Blank)

1. Remove the field wiring cover and check the power supply voltage. The voltage across the + and - terminals must be between 15.5 and 42 volts dc.
2. Make sure there is no moisture in the termination compartment. Moisture could be a result of a loose cable/conduit connection or a cover that was not fully engaged.
3. If voltage at the terminals is 0, check for a blown fuse in power supply or for damaged wires.
4. If voltage is below minimum, check the loop load vs supply voltage per Figure 20.
5. If voltage is correct, check the voltage on the cable inside the housing to verify the protection circuit in the terminal block assembly has not been damaged. If no voltage is present on the cable inside the housing, replace the terminal block assembly.

Flowmeter Has No Output With Flow, But Has a 4 mA Signal and a Lighted Display (If So Equipped).

1. Check the LFCI setting. This sets the point where the mA output remains at 4 mA from zero flow to the LFCI flow rate. If flow is above this level, and there is still no change in output, proceed as follows:
2. Check the flowmeter status to see it has not "failed low". The flowmeter is configurable to fail either "low" or "high". The mA value in the fail-low mode is 3.6 mA. (The mA value in the fail-high mode is 22 mA.)

3. Check to see that the module can output the desired mA or pulse output frequency by going to the Test mode and setting the outputs as previously described.

Flowmeter Output Increases With Flow, However When It Approaches Full Scale, the Output Suddenly Goes To 4 mA.

1. This is indicative of an intrinsically safe loop that is using a passive (unpowered) barrier. As the mA value increases, the voltage at the terminals has dropped below the minimum and the output has gone to 4 mA.
2. Install an active (externally powered) barrier such as a Pepperl+Fuchs model KFD0-SCS-Ex1.55

Flowmeter with Remote Mounted Electronics Has No Output or Low Output With Flowing Conditions

1. Perform a visual analysis of the preamplifier to observe any discoloration as a result of over heating the remote mounted pre-amplifier. Check the maximum ambient temperature specification per the electrical certification table and/or the product label.
2. Make sure there is no moisture in the termination compartment. Moisture could be a result of a loose cable/conduit connection or a cover that was not fully engaged.
3. Check the voltage levels at the junction box located on top of the flow meter body. The following values should be observed:
 - a. Red to yellow: + 3.0 +/- 0.3 volts
 - b. Orange to yellow: - 3.0 +/- 0.3 volts.

If these values are not observed there is likely a break or cut in the cable between the flowmeter and the remote electronics. Or, the pre-amplifier may not be working.

4. Check to verify the sensor wires and cable wires are fully engaged in the clamp-type connectors. This can be done by lightly "tugging" on each wire, assuring it is securely held in place by the connector. Also check to make sure the connector is not clamping the wire insulation instead of the conductor. If any wires are not engaged, depress the lever in the connector, insert the bare conductor, and release the lever, re-checking the wire to assure it is firmly clamped.
5. Check for sensor output. This can be done with a small portable scope meter. There should be a sine-like wave form on the meter. This wave form does not have to be sinusoidal, but alternating output should be observed. The amplitude of the signal is dependant on sensor type and velocity. The frequency of the output should be in accordance with the expected flow rate.
6. Check the pre-amplifier:
 - a. Disconnect the sensor leads
 - b. For a standard temperature sensor, connect a 2200 pF +/- 5% 50V NPO ceramic capacitor to the + (brown) terminal of the sensor terminal block.

- c. Connect a portable frequency generator that can supply a sinusoidal 0.5 volt peak-to-peak signal to the sensor input terminals.
- d. Compute the expected sensor frequency for the flow rate going through the flowmeter. (Use FlowExpertPro for making this determination, or compute the frequency based on the meter K-factor (this is stamped on the flowmeter body).
- e. Re-check the output at the remote electronics. If there is output at the electronics, the sensor is likely not working and needs to be replaced.
- f. If there is no output at the remote electronics, proceed to check the pre-amplifier by disconnecting the brown and yellow wires from the remote cable. (Note: the orange and red wires need to stay connected to provide power to the pre-amplifier.) Connect the scope meter to the brown and yellow (+ and -) terminals on the output terminal block. The amplitude of the signal should be approximately the same amplitude (0.5 volts) of the input signal and the same frequency.
- g. For flowmeters with an extended temperature sensor, replace the 2200 pF capacitor with a 22pF capacitor. Set the frequency input amplitude to 0.5 volts peak to peak. The output from the preamplifier should be 1.5X the input value or 0.75 volts peak to peak, and be at the same frequency as the input.
- h. If the output from the pre-amplifier is correct, proceed to check out the cable for breaks or cuts, and verify the remote cable is correctly connected to the junction box at the flowmeter.
- i. The remote cable is factory-terminated and sealed at the electronics end. The cable cannot be removed or re-terminated at the electronics end. If the cable has been tampered with at the electronics end, this is likely the root cause of the improperly working flowmeter and requires replacement.
- j. If the flowmeter still has no output, proceed to the electronics module test.

Electronics Module Test

1. Remove the electronics compartment cover at the remote electronics.
2. Make sure there is no moisture in the electronics compartment. Moisture could be a result of a loose cable/conduit connection or a cover that was fully engaged. A build up of corrosive moisture in this compartment could affect the performance of the electronics. Also examine the electronics for exposure to excessive heat. The maximum temperature the electronics can withstand is 80°C (176°F). Make sure the installation is such that the electronics do not exceed this temperature.
3. Test the mA or pulse output by putting the flowmeter in the Test mode and setting either the mA or pulse output value. If the meter has no output in this test mode, replace the module. If there is output from the meter, proceed to the next step.
4. Remove the electronics from the compartment by loosening the two captured screws.
5. Check the inside for broken or pinched wires and/or connectors that are not engaged.
6. Check the voltage level at the cable end of the blue and red wires. The voltage should be the same as was measured on the field terminals. Should there be a difference, the

- terminal block electronics assembly may have been damaged in a severe transient (lightening strike).
7. Remove the 4-wire connector from the back of the electronics module. This is the signal input connector from the sensor to the electronics module. In place of this connector, connect a test connector (part number K0152KU).
 8. Connect a frequency generator to the brown (+) and yellow (-) wires. Inject a sinusoidal 0.5 V peak to peak signal that is in the vortex shedding frequency range for the flowmeter. Observe there is a change in the 4-20 mA or rate pulse output signal. Change the input frequency over the expected vortex frequency range and verify the output changes accordingly.
 9. If there is still no output, replace the electronics module.

Flowmeter Has Incorrect Output

1. Output is lower than expected at all flow rates
 - a. Verify that the upper range value (URV) is correct.
 - b. Verify that the zero and span of the mA output is correct.
 - c. Check for vibration levels, that may influence the output signal. This is best accomplished by following the procedure for setting the low flow cut-in in “Flowmeter Output Indicates Flow When There Is No Flow” on page 71.
 - d. Check the flowmeter configuration to verify that the fluid flowing density is entered correctly. An incorrect configuration could result in band pass filters being set to improper values, with in-band signals being adversely affected.
 - e. Check the load resistance.
 - f. In the test mode, verify that the mA output at the receivers is correct.
2. Output is lower than expected at low-flow rates.

Check the steps in the above test, however if the problem only appears at low flow rates, the likelihood is that there is a pulsating flow condition, resulting in missed pulses when the fluid velocity is very low.
3. Output is constant when flow is increasing or decreasing.
 - a. This condition is likely the result of an in-band noise source. Where the vortex signal is being over-ridden by the noise source.
 - b. Check the LFCI setting procedure. Check the URV value to make sure that it is in line with the actual measurement range.
4. Output is greater than the expected value.
 - a. Test the above.
 - b. Verify that the flowmeter is not in a "fail safe" mode where full scale output has been configured as the fail safe output condition.
 - c. Verify the URV is correctly configured.
5. Incorrect pulse output value.
 - a. Check the configuration of the pulse output to verify that it is correct.

- ◆ Raw Pulse: the raw vortex shedding frequency.
 - ◆ Rate Pulse: verify that the rate pulse is configured to the correct full range value of 10 Hz, 100 Hz, or 1000 Hz.
 - ◆ Total pulse: verify that the total pulse is properly defined.
- b. If rate pulse is configured, set the output frequency in the test mode and verify the correct value.

6. Maintenance

 **CAUTION**

Components in your flowmeter are ESD sensitive and thus are susceptible to damage resulting from electrostatic discharge. Invensys Foxboro recommends that you be grounded via a conductive wrist strap or by standing on an ESD mat when performing maintenance in the electronics compartment or the remote junction box, and if the housing is removed.

Introduction

The operation of the 84F-T, 84F-U, 84W-T, and 84W-U Vortex Flowmeters consists of three basic functions: (1) generation and shedding of vortices in the fluid stream, (2) sensing of vortices, and (3), amplification, conditioning, and processing of the signal from the vortex sensor. Should a malfunction of the flowmeter be suspected, the cause can normally be isolated to one of these three functions.

Personnel involved in maintenance of vortex meters should be trained and qualified in the use of the equipment required and in the removal and replacement of the meter in the piping. They should also be qualified for the routine maintenance of the meter components.

Vortex Generation and Shedding

The process of vortex generation and shedding can be degraded or destroyed by disturbances in the upstream flow, the nature of the flowing fluid, or by damage to the vortex shedding element (rare). Such flow disturbances may be created by gaskets protruding into the flowing stream, by some form of partial blockage in the upstream piping, by the piping configuration, or by the existence of two-phase flow. Should the vortex shedding element become heavily caked, coated, or physically damaged to the extent that its basic shape or dimensions are changed, the vortex shedding process may be impaired. Also, the length of straight, unobstructed run of upstream piping is important (refer to “Upstream and Downstream Disturbances” on page 13).

Vortex Sensing

There are two basic types of sensors employed by both the 84F and 84W Vortex Flowmeters - Standard Temperature and Extended Temperature Range. The Standard Temperature Range sensor may be filled with Fluorolube for applications with process temperature limits of -20 to $+90^{\circ}\text{C}$ (0 to 200°F) or with Silicone oil for applications with process temperature limits of -20 to $+200^{\circ}\text{C}$ (0 to 400°F). The Extended Temperature Range sensor is an unfilled sensor for applications to 430°C (800°F).

The Standard Temperature Range sensor consists of a piezoelectric bimorph crystal that is sealed inside a liquid-filled capsule having two diaphragms on opposing sides. The vortex shedding process creates an alternating differential pressure across the capsule that is transmitted via the diaphragms and fill-fluid to the crystal.

The Extended Temperature Range sensor consists of two piezoelectric crystals sealed inside a capsule having two process diaphragms, on opposing sides, connected internally by a mechanical shuttle. The vortex shedding process creates an alternating differential pressure across the capsule that is transmitted via the diaphragm-shuttle mechanism to the crystals.

The alternating force acting on the crystals causes them to develop a pulsed voltage with a frequency equal to the vortex shedding frequency. Damage to sealing diaphragms or other physical damage could cause the sensors to operate improperly.

Electronic Module

The electronic module is housed in the flowmeter housing opposite the side labeled **FIELD TERMINALS**. On the back of the module are three terminal blocks. See Table 14 for a summary of the terminal block connections.

Table 14. Electronic Module Terminal Block Connections

No. of Connectors	Color	Description
2	Red Blue	Loop + Loop -
2	Yellow Green	Pulse Out + Pulse Out -
4	Brown (B) Red (R) Orange (O) Yellow (Y)	Sensor + or Preamp Out + Preamp Power + Preamp Power - Sensor - or Preamp Out -

— NOTE —

Integrally mounted flowmeters with standard temperature range do **not** have a preamplifier. Integrally mounted flowmeters with extended temperature range and all remotely mounted flowmeters **do** have a preamplifier.

Electronic Module Removal

Refer to Figure 39.

— WARNING —

Before proceeding, ensure that power is removed from the flowmeter.

1. For flowmeters with housing cover locks, screw the electronic compartment cover lock screw into the housing to unlock the cover.
2. Remove electronic module compartment threaded cover.

— NOTE —

If the cover cannot be removed by hand, insert a flat bar in the cover slot.

3. If a display is mounted to the electronic module, remove the display by loosening the two mounting screws and unplugging the ribbon cable from the electronic module.

4. Unscrew the two captive screws, one on each side of the electronic module.
5. Pull the electronic module out of the housing far enough to be able to disconnect the wires from the terminal blocks on the back of the electronic module.
6. Disconnect the mA output (red - blue), pulse output (yellow - green), and preamplifier/sensor (brown - red - orange - yellow) cable connectors from the 2-, 3-, and 4-pin terminal blocks respectively.
7. Remove the electronic module from the housing.

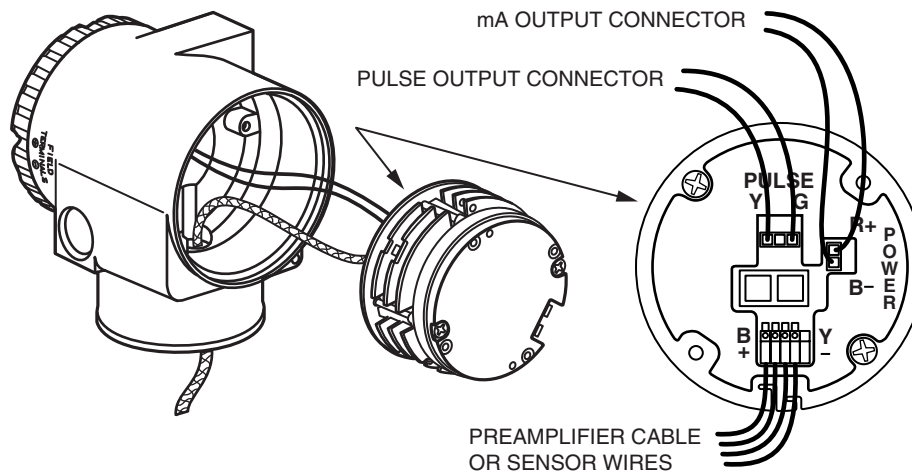

Figure 39. Electronic Module Connections

Electronic Module Replacement

Refer to Figure 39.

— **WARNING** —

Before proceeding, ensure that power is removed from the flowmeter.

1. Remove the electronic module. See “Electronic Module Removal” on page 78.

— **CAUTION** —

The replacement electronic module is shipped in a protective antistatic plastic bag. Do **not** remove it from this bag **until** it is ready to be installed in a flowmeter. This minimizes the possibility of damage due to accidental electrostatic discharge.

2. Remove the new electronic module from its protective bag.
3. Connect the mA output (red - blue) and pulse output (yellow - green), and preamplifier/sensor (brown - red - orange - yellow) cable connectors to the 2-, 3-, and 4-pin terminal blocks respectively on the back of the electronic module.
4. Back the two captive screws out of the module until the screws are captured by the plastic housing.
5. Locate the electronic module in the housing over the two mounting holes. Tighten the captive mounting screws.

6. If the electronic module was equipped with a display, reassemble the display. Carefully fold the ribbon cable in the space between display and the electronic module so that it is not pinched. The display molding should rest firmly against the module molding before tightening the screws. See Figure 40.

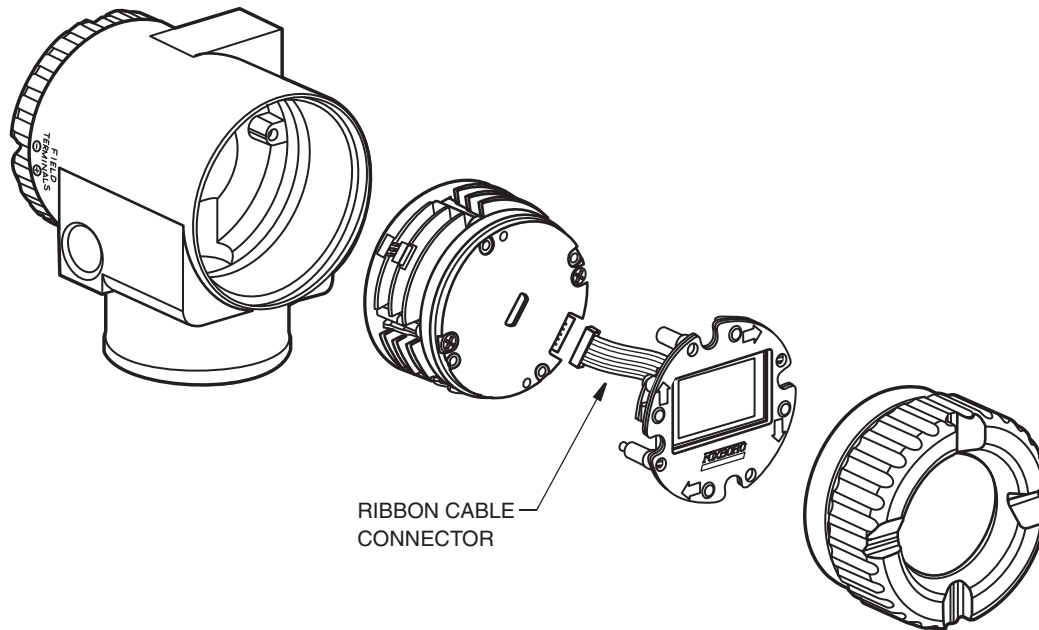

Figure 40. Display Connection

7. The new electronic module must be configured to match the one just removed.
8. Perform the “Post-Assembly Dielectric Test” on page 85.
9. Replace the electronic compartment cover. On flowmeters with housing cover locks, relock the electronic compartment cover **before** operating the flowmeter.

Neck Board Replacement

All 84F and 84W Series Vortex Flowmeters have a printed wiring board located in the neck of the instrument. This board (henceforth referred to as a neck board) functions as a preamplifier, barrier and/or interface depending on the specific model.

Preamplifier Board: In integrally mounted flowmeters with extended temperature range.

Barrier Board: In flowmeters with explosionproof/flameproof electrical certification. These flowmeters also have a PE ground in the electronics housing which must be disconnected as part of the preamplifier replacement procedure.

Interface Board: In all 84 Series flowmeters.

Removal Procedure

 **WARNING**

Before proceeding, ensure that power is removed from the flowmeter.

1. Remove the electronic module. See “Electronic Module Removal” on page 78.
2. If your flowmeter has explosionproof/flameproof electrical certification, disconnect the two wires from the PE ground screw in the electronics housing.
3. Turn the housing set screw three full turns counterclockwise (see Figure 18 for location) and unscrew the housing.
4. Disconnect the wires from the 4-position terminal block on the neck board.
5. Remove the two screws securing the neck board in its cup and remove the board from the cup. Save the screws (and barrier if applicable).

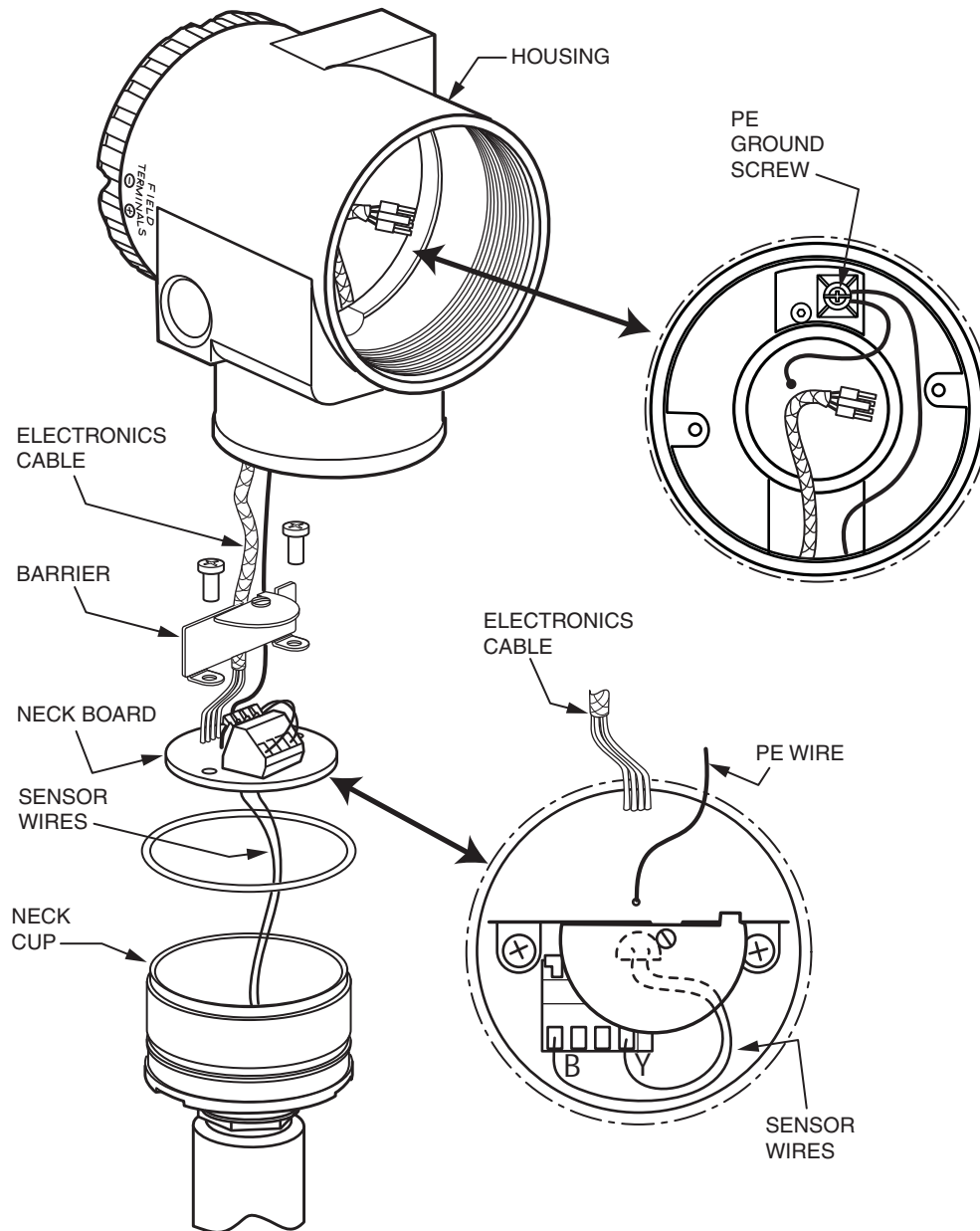

Figure 41. Preamplifier Assembly - Integrally Mounted

Installation Procedure

— **⚠ WARNING** —

Before proceeding, ensure that power is removed from the flowmeter.

— **NOTE** —

The replacement neck board is shipped in a protective antistatic plastic bag. Do **not** remove the preamplifier from this bag **until** it is ready to be installed in a flowmeter. This prevents damage due to accidental electrostatic discharge.

1. Remove the neck board. See “Removal Procedure” on page 81.
2. Feed the (2 or 4) wires from the cup through the hole in the center of the neck board and connect them to the 4-position terminal block on the board.
3. Install the neck board into its cup and secure it (and the barrier if applicable) with the two screws previously removed.
4. Feed the electronics cable (and the PE ground wire if applicable) through the housing neck and into the electronics compartment.
5. Screw the housing onto the cup. Hand tighten. Then engage the set screw (see Figure 18) until it bottoms out and back it off 1/8th turn. Fill the set screw recess with red lacquer (Foxboro Part number X0180GS or equivalent). The housing then may be rotated up to one full turn in a counterclockwise direction for optimum access to adjustments.
6. If your flowmeter has explosionproof/flameproof electrical certification, reconnect the two (green) PE ground wires to the PE ground screw in the electronics housing.
7. Connect the mA output (red - blue) and pulse output (yellow - green), and electronics (brown - red - orange - yellow) cable connectors to the 2-, 3-, and 4-pin terminal blocks respectively on the back of the electronic module.
8. Back the two captive screws out of the module until the screws are captured by the plastic housing.
9. Rotate the module one-half to one full turn to slightly twist the wires together.
10. Locate the electronic module over the mounting holes, assure that no wires are pinched, and tighten the captive mounting screws.
11. Perform the “Post-Assembly Dielectric Test” on page 85.
12. Replace the electronic compartment cover. On flowmeters with housing cover locks, relock the electronic compartment cover **before** operating the flowmeter.

Preamplifier Replacement

With integrally mounted electronics, the preamplifier is located on the neck board. See “Neck Board Replacement” on page 80.

With remotely mounted electronics, use the following procedure referring to Figure 42.

Removal Procedure

—  **WARNING** —

Before proceeding, ensure that power is removed from the flowmeter.

1. On flowmeters with a junction box cover lock, remove the lock.
2. Remove the junction box threaded cover.

— **NOTE** —

If the cover cannot be removed by hand, insert a flat bar in the cover slot.

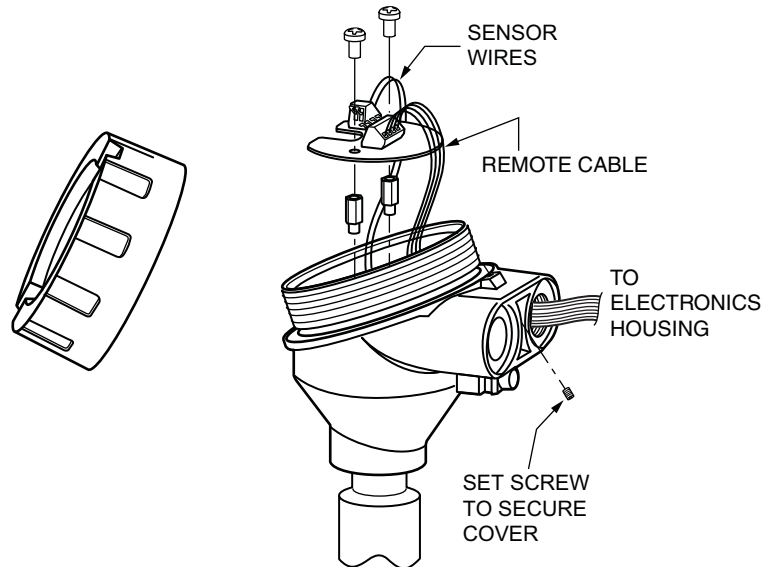

Figure 42. Preamplifier Assembly - Remotely Mounted

3. Disconnect the (brown-red-orange-yellow) preamplifier wires from the 4-position terminal block and the (yellow and brown) sensor wires from the 2-position terminal block.

— **⚠ CAUTION** —

Note the position of the wires because the placement of colored wires in the correct position on the new preamplifier board is important.

4. Remove the preamplifier by removing the two screws securing it. Save the screws.

Installation Procedure

— **⚠ WARNING** —

Before proceeding, ensure that power is removed from the flowmeter.

— **NOTE** —

The replacement preamplifier is shipped in a protective antistatic plastic bag. Do **not** remove the preamplifier from this bag **until** it is ready to be installed in a flowmeter. This prevents damage due to accidental electrostatic discharge.

1. Remove the preamplifier. See “Removal Procedure” on page 83.

— **NOTE** —

There are two preamplifier boards - be sure to install the correct board.
L0123HT for a standard temperature flowmeter and
L0123HV for an extended temperature flowmeter.

2. Connect the (yellow and brown) sensor wires to the 2-position terminal block and the (brown-red-orange-yellow) preamplifier wires to the 4-position terminal block.

3. Mount the new preamplifier in the junction box using the two screws you saved when removing the old preamplifier.
4. Perform the “Post-Assembly Dielectric Test” below.
5. Replace the threaded junction box cover. On flowmeters with cover locks, relock the junction box cover **before** operating the flowmeter.

Post-Assembly Dielectric Test

To ensure there are no faults to ground in any of the internal wiring, apply 500 V ac or 707 V dc dielectric strength test for one minute between shorted input terminals and housing ground as shown in Figure 43.

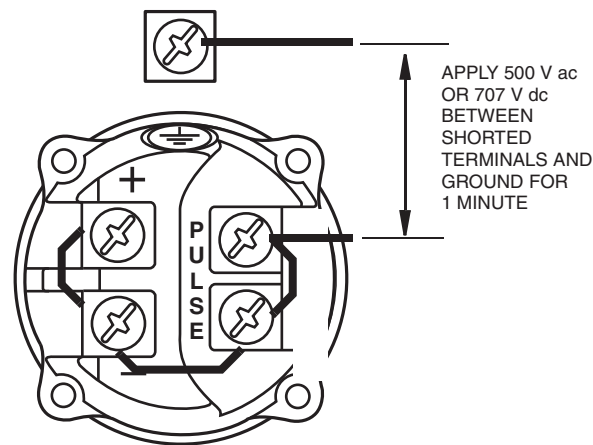

Figure 43. Connections for Post-Assembly Dielectric Test

Sensor Replacement

The flowmeter does not need to be removed from the pipeline for sensor replacement. The pipeline must, however, be shut down and emptied before loosening the connector bolts.

Replacing the sensor does not cause a shift in the K-factor. Therefore, the flowmeter does not require recalibration.

— CAUTION —

The placement of colored wires in the correct position in the terminal blocks is important. Verify correctness.

Integrally Mounted Flowmeter

Refer to Figure 44.

Sensor Assembly Removal

— **WARNING** —

Before proceeding, ensure that power is removed from the flowmeter.

1. Remove the electronic module. See “Electronic Module Removal” on page 78.
2. If your flowmeter has explosionproof/flameproof electrical certification, disconnect the two wires from the PE ground screw in the electronics housing.
3. Turn the housing set screw three full turns counterclockwise (see Figure 18 for location) and unscrew the housing.
4. Disconnect the (yellow and brown) sensor wires from the 4-position terminal block on the neck board.
5. Remove the mechanical connector bolts and lift off the electronic housing, mechanical connector, and sensor assembly as a unit.
6. Slide the sensor assembly out of the mechanical connector.

Sensor Assembly Installation

— **NOTE** —

Before beginning the assembly procedure, verify that you have the correct kit of parts. Kit part numbers can be found in PL 008-714 (for 84F) or PL 008-716 (for 84W).

The sensor kits consist of:

- ◆ 1 Sensor assembly
- ◆ 1 Sensor seal kit (containing an O-ring, gasket, and flow dam)
- ◆ 4 Mechanical connector bolts
- ◆ 2 Tie wraps

— **WARNING** —

Before proceeding, ensure that power is removed from the flowmeter.

1. If the flow dam has remained in the flowmeter body, remove it before starting to re-assemble.
2. Slide the O-ring over the sensor wires and onto the neck of the sensor.
3. Feed the sensor wires through the hole in the mechanical connector until the sensor is touching the mechanical connector and the wires extend through the hole in the center of the neck board.
4. Place the new flat gasket over the sensor in contact with serrated sealing surface. Center the gasket. Slide the new flow dam into the groove of the sensor.
5. Insert the sensor with the connector into the flowmeter body and secure with four **new** connector bolts finger tight.

! WARNING

Do **not** use the connector bolts in the sensor replacement kits for 84F-xxxxxL flowmeters (dual measurement with isolation valves). Use four X0173TF bolts as shown in the parts list.

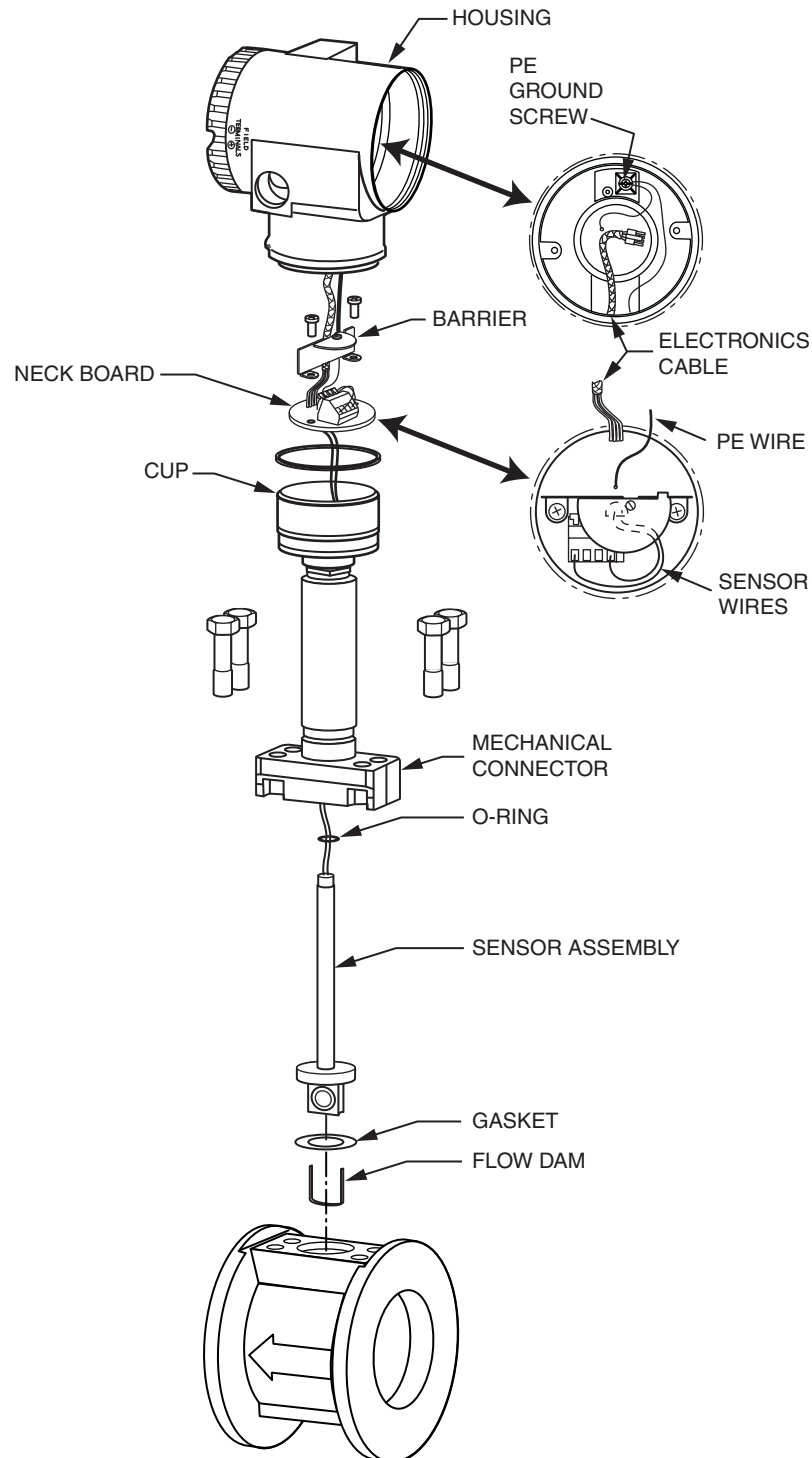

Figure 44. Sensor Replacement - Integrally Mounted Flowmeter

! WARNING

It is important that the gasket be sealed uniformly to provide a good seal. The following two steps assure a uniform seal. Failure to follow these steps could result in personal injury due to gasket leakage.

6. Tighten all connector bolts in steps of 1.4 N•m (1 lb•ft) up to 2.8 N•m (2 lb•ft) per the sequence shown in Figure 45.

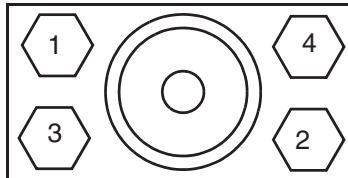

Figure 45. Connector Bolt Torquing Sequence

7. Continue to tighten in steps of 7 N•m (5 lb•ft) up to 34 N•m (25 lb•ft) using the same sequence.
8. Connect the (yellow and brown) sensor wires to the 4-position terminal block on the neck board.
9. Install the neck board into its cup and secure it (and the barrier if applicable) with the two screws previously removed.
10. Feed the electronics cable (and the PE ground wire if applicable) through the housing neck and into the electronics compartment.
11. Screw the housing onto the cup. Hand tighten. Then engage the set screw (see Figure 18) until it bottoms out and back it off 1/8th turn. Fill the set screw recess with red lacquer (Foxboro Part number X0180GS or equivalent). The housing then may be rotated up to one full turn in a counterclockwise direction for optimum access to adjustments.
12. If your flowmeter has explosionproof/flameproof electrical certification, reconnect the two (green) PE ground wires to the PE ground screw in the electronics housing.
13. Connect the mA output (red - blue) and pulse output (yellow - green), and electronics (brown - red - orange - yellow) cable connectors to the 2-, 3-, and 4-pin terminal blocks respectively on the back of the electronics module.
14. Locate the electronics module over the mounting holes and tighten the captive mounting screws.
15. Replace the electronic compartment cover. On flowmeters with housing cover locks, relock the electronic compartment cover **before** operating the flowmeter.

! WARNING

In order to maintain agency certification of this product and to prove the integrity of the parts and workmanship in containing process pressure, a hydrostatic pressure test **must** be performed. The meter must hold for one minute without leaking the appropriate pressure from Table 15.

Table 15. Maximum Test Pressure

Model	End Connection	Test Pressure
84F	ANSI Class 150	450 psi
	PN 16	3.2 MPa
	ANSI Class 300	1125 psi
	PN 40	6 MPa
	PN 64	9.6 MPa
	ANSI Class 600	2250 psi
	PN 100	15 MPa
84W	All	15 MPa (2250 psi)

Remotely Mounted Flowmeter

Refer to Figure 46.

Sensor Assembly Removal

— **⚠ WARNING** —

Before proceeding, ensure that power is removed from the flowmeter.

1. On flowmeters with a junction box cover lock, remove the cover lock.
2. Remove the junction box threaded cover.

— **NOTE** —

If the cover cannot be removed by hand, insert a flat bar in the cover slot.

3. Disconnect the (yellow and brown) sensor wires from the 2-position terminal block on the preamplifier.
4. Remove the mechanical connector bolts.
5. Lift off the junction box, mechanical connector, and sensor assembly as a unit.
6. Slide the sensor assembly out of the mechanical connector.

Sensor Assembly Installation

— **NOTE** —

Before beginning the replacement procedure, verify that you have the correct kit of parts. Kit part numbers can be found in PL 008-714 (for 84F) or PL 008-716 (for 84W).

The sensor kits consist of:

- ◆ 1 Sensor assembly
- ◆ 1 Sensor seal kit (containing an O-ring, gasket, and flow dam)

- ◆ 4 Mechanical connector bolts
- ◆ 2 Tie wraps

—  **WARNING** —

Before proceeding, ensure that power is removed from the flowmeter.

1. If the flow dam has remained in the flowmeter body, remove it before starting to reassemble.
2. Slide the O-ring over the sensor lead and onto the neck of the sensor.
3. Feed the sensor wires through the hole in the mechanical connector until the sensor is touching the mechanical connector and the wires extend through the slot in the center of the preamplifier board.

— **NOTE** —

It may be helpful to use a straw as a tool to do this. Slide a straw over the sensor wires and feed the straw through the mechanical connector and preamplifier board. Then remove the straw.

4. Place the new flat gasket over the sensor in contact with the serrated sealing surface. Center the gasket. Slide the new flow dam into the groove of the sensor.
5. Insert the sensor with the connector into the flowmeter body and secure with four **new** connector bolts finger tight.

—  **WARNING** —

Do **not** use the connector bolts in the sensor replacement kits for 84F-xxxxxL flowmeters (dual measurement with isolation valves). Use four X0173TF bolts as shown in the parts list.

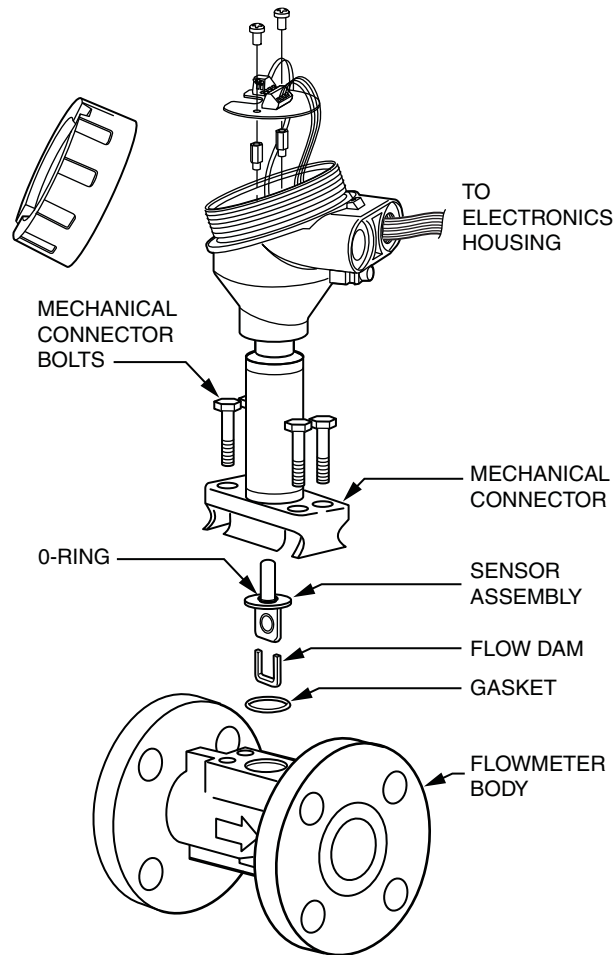

Figure 46. Sensor Replacement - Remotely Mounted Flowmeter

— **! WARNING** —

It is important that the gasket be sealed uniformly to provide a good seal. The following two steps assure a uniform seal. Failure to follow these steps could result in personal injury due to gasket leakage.

6. Tighten all connector bolts in steps of 1.4 N•m (1 lb•ft) up to 2.8 N•m (2 lb•ft) per the sequence shown in Figure 45.
7. Continue to tighten in steps of 7 N•m (5 lb•ft) using the same sequence. The maximum torque needed for safe operation is 34 N•m (25 lb•ft).
8. Connect the (yellow and brown) sensor wires to the 2-position preamplifier terminal block.
9. Replace the threaded junction box cover. On flowmeters with cover locks, relock the junction box cover **before** operating the flowmeter.

— **! WARNING** —

In order to maintain agency certification of this product and prove integrity of the parts and workmanship in containing process pressure, a hydrostatic pressure test

must be performed. The meter must hold for one minute without leaking the appropriate pressure from Table 15.

Appendix A. Isolation Valves

Isolation valving is available in single and dual measurement versions for standard and extended range sensors. The following procedure applies to all versions. Replacing the sensor in this type of unit is essentially the same as replacing a sensor in units without isolation valving. However, particular care must be taken since the process does not need to be shut down.

—  **WARNING** —

The isolation valve must be in the closed position prior to replacing the sensor. It must be gradually depressurized so that process fluid does not leak. Personal injury could result from such a leak. Follow normal lockout procedures. Remove power from the flowmeter.

Replacing the Sensor

1. Close the valve. This is a dual port, single ball 1/4-turn valve. Use a wrench on the flat on the valve stem to turn clockwise one quarter turn. See Figure 48.

— **NOTE** —

The right angle position indicator attached to the stem is **not** a valve handle. Use a wrench on the valve stem flats.

2. Allow the unit to cool down as required.
3. Remove power from the flowmeter.
4. Gradually loosen the four top bolts that connect the mechanical connector to the top surface of the valve body. Do **not** loosen the bottom bolts.
5. Allow trapped process fluid within valve body to depressurize.
6. Remove the bolts loosened in Step 4 and lift off the housing, mechanical connector, and sensor as a unit.
7. Replace the sensor following the instructions in “Replacing the Sensor” on page 93. Be sure the O-ring is installed on the sensor and use a new flow dam and gasket.

—  **CAUTION** —

Since it is not possible to leak test the valve-to-connector joint, it must be assembled carefully.

8. Open the valve counterclockwise. Use care and check for leaks.

— **NOTE** —

Replacing the sensor does not cause a shift in the K-factor. Therefore, the meter does not require recalibration.

Replacing or Installing an Isolation Valve

The flowmeter does not need to be removed from the pipeline to replace the isolation valve. However, the pipeline must be shut down and emptied before loosening the mounting bolts.

1. If the flowmeter is wired with rigid conduit, it may be necessary to disconnect the input wiring and conduit connections.
2. Remove the top bolts holding the connector and the bottom bolts holding the valve body.
3. Install a new gasket and flow dam on the lower section of the valve body and assemble the valve into the flowmeter body. Refer to Figure 48 or Figure 49. These are the same gaskets and flow dams used with sensors.
4. Install the four bolts on the bottom flange finger tight.

! WARNING

It is important that the gasket be sealed uniformly to provide a good seal. The following two steps assure a uniform seal. Failure to follow these steps could result in personal injury due to gasket leakage.

5. Tighten all connector bolts in steps of 1.4 N•m (1 lb•ft) up to 2.8 N•m (2 lb•ft) per the sequence shown in Figure 47.

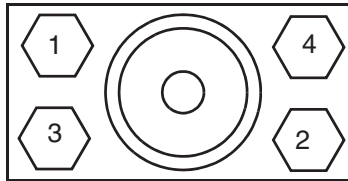

Figure 47. Connector Bolt Torquing Sequence

6. Continue to tighten in steps of 7 N•m (5 lb•ft) up to 34 N•m (25 lb•ft) using the same sequence.
7. Install a new gasket and flow dam on the sensor. Hold the sensor, mechanical connector, and housing together and carefully slide the sensor into the top of the valve body.
8. Install the four bolts on the top flange and tighten, using the procedure explained in Steps 4 through 6.

! WARNING

It is important that the gasket be sealed uniformly to provide a good seal. Failure to follow these steps could result in personal injury due to gasket leakage.

9. Reconnect the conduit and external wiring. Refer to “Electrical Installation” on page 25.

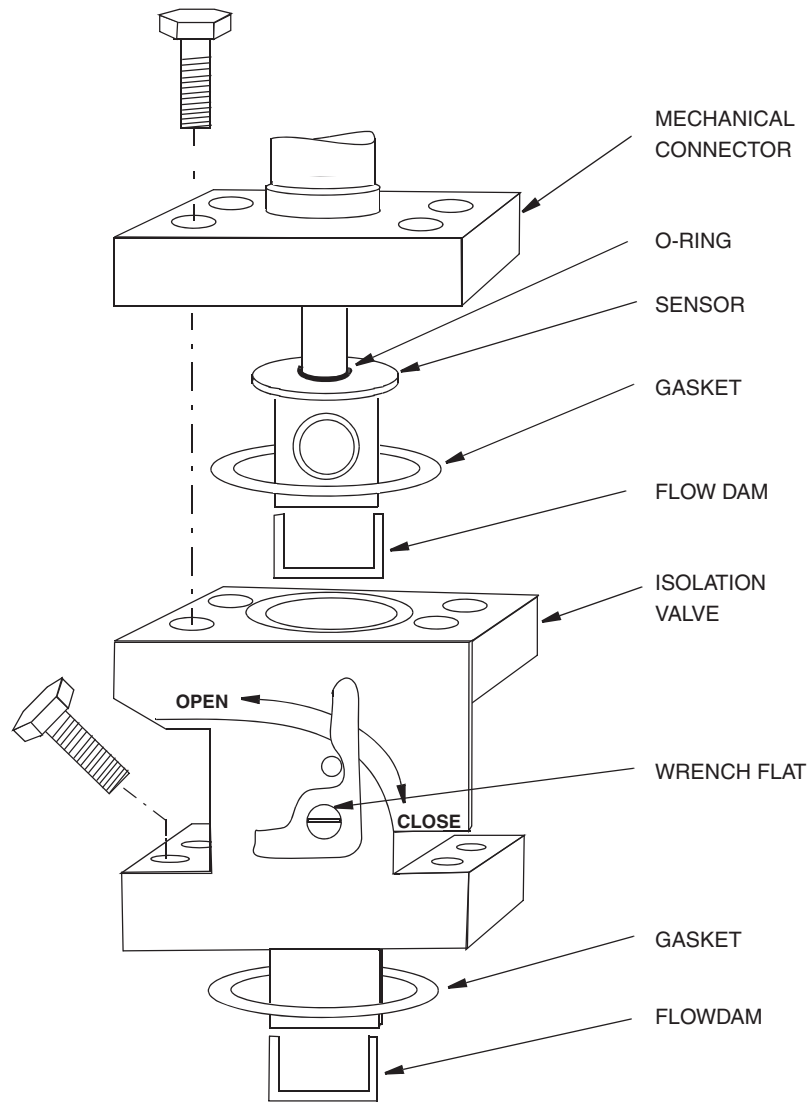

Figure 48. Isolation Valve

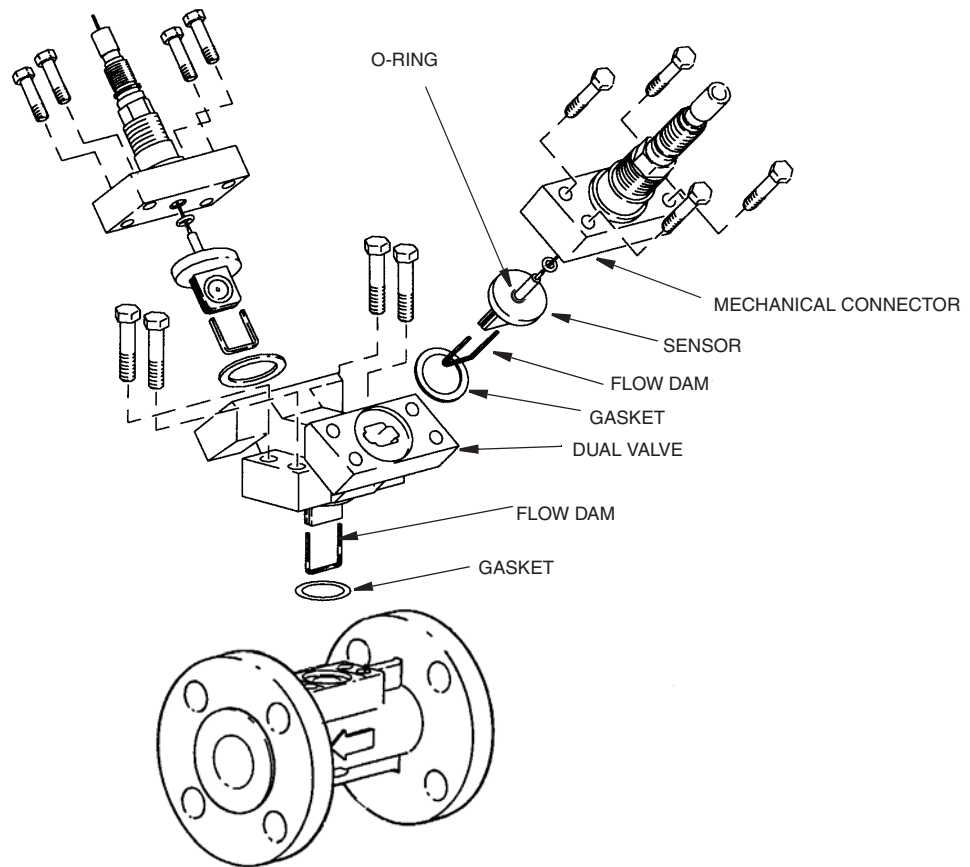

Figure 49. Dual Manifold

Index

C

Calibration/Test Mode 55
Configuration Database 40
Cover Locks 24

D

Database, Configuration 40
Dielectric Test 85
Dimensions 12
Display, Positioning the 24

E

Electrical Safety Specifications 6
Electronic Module 78
 Removal 78
 Replacement 79
Error Messages 58

F

Flow Parameter, Setting 47
Flowtube Parameters, Setting 51
Fluid Parameters, Setting 47

H

Housing, Positioning the 25

I

Identification 11
Installation 11
 Mechanical 12
Isolation Valves 93
 Replacing or Installing an Isolation Valve 94
 Replacing the Sensor 93

L

Local Display 37

M

- Maintenance 77
- Measure Mode 44
- Menu Tree, Setup 53
- Menu Tree, Using the 41
- Mounting the Remote Electronics Housing 23

N

- Neck Board Replacement 80

O

- Operation via Local Display 37
- Output Parameters, Setting 48

P

- Password 38
- Piping 12
 - Effects of Piping on Flowmeter Performance 13
 - Gas Installations 15
 - Liquid Installations 14
 - Location of Pressure and Temperature Taps 20
 - Steam Installations 15
- Piping Parameters, Setting 49
- Preamplifier Replacement 83

R

- Reference Documents 1

S

- Sensor Replacement 85
- Setup Menu Tree 53
- Setup Mode 46
- Specifications
 - Electrical Safety 6
 - Standard 1
- Status Mode 44

T

- Tag Parameters, Setting 51
- Totals Mode 44
- Totals Parameters, Setting 48
- Troubleshooting 71
- Tuning Parameters, Setting 48

U

Unpacking 11

V

View Mode 46

W

Wiring

Field Termination 29

For 4 to 20 mA Output 30

For Pulse Output 33

Write Protect Jumper, Setting the 25

33 Commercial Street
Foxboro, MA 02035-2099
United States of America
<http://www.foxboro.com>
Inside U.S.: 1-866-746-6477
Outside U.S.: 1-508-549-2424
or contact your local Foxboro
Representative.
Facsimile: (508) 549-4999

Invensys, Foxboro, I/A Series, and FlowExpert Pro are trademarks of Invensys plc, its subsidiaries, and affiliates.
All other brand names may be trademarks of their respective owners.

Copyright 2007 Invensys Systems, Inc.
All rights reserved

MB 100

Printed in U.S.A.

0207