

# Masoneilan\* Valves

## 35002 Series Camflex\* II

### Rotary Control Valves

The 35002 Series Camflex II Eccentric Plug Rotary Control Valve features an extension bonnet, hardened trim, and high-performance low-emission packing, providing broad application coverage and exceptional long-term reliability.

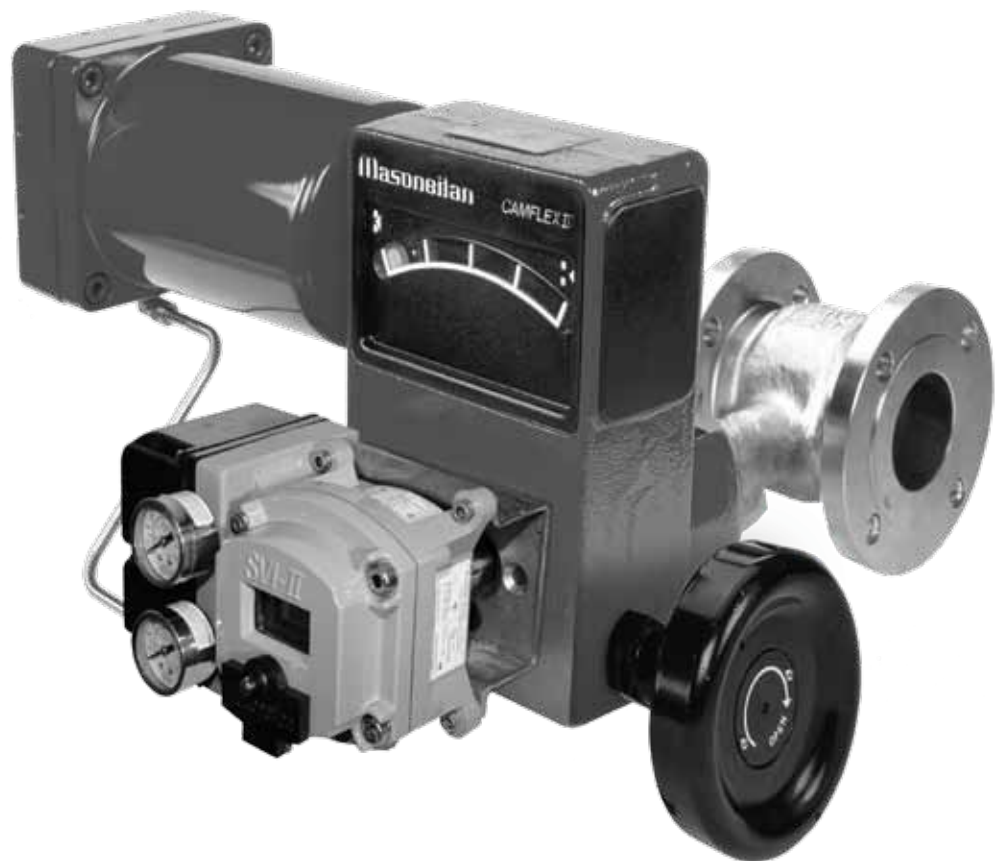

imagination at work

# Table of Contents

Features.....	2	(C <sub>v</sub> ) and (F <sub>L</sub> ) Versus Travel.....	7-8
Numbering System.....	3	(C <sub>v</sub> ) Versus Travel.....	9
Actuator Mounting Guide.....	4	Materials of Construction.....	10-14
General Data / Ratings and Connections.....	5-6	Dimensions and Weights.....	15-16

## Features

The Camflex\* II valve is a heavy-duty, automatic-throttling control valve that incorporates the following features:

- The flangeless body rating is a rugged ANSI Class 600.
- Heavy-duty guide lugs assure quick, positive alignment during installation.
- The flanged version is available at 1 in. through 12 in. (25 mm through 300 mm) in 150 or 300 ANSI, and 1 in. through 8 in. (25 mm through 200 mm) in 600 ANSI.
- Separable bonnet design is available.
- Straight through flow pattern provides greater flow capacities.
- Standard integral extension bonnet allows for a wide range of fluid temperature applications (-320°F to 750°F), (-196°C to 400°C).
- The unique self-aligning eccentric rotating plug provides tight shutoff and low dynamic forces.
- A large variety of reduced-trim options are available in all sizes.
- The triple, over-sized bearing system provides exceptional plug shaft guiding.
- The shouldered shaft design is utilized.
- An optional patented differential velocity device (DVD) separates compressible flowstreams into a high velocity core and a low velocity envelope flowstream. This provides up to 18 dBA noise attenuation.
- Optional alloy constructions are available.
- The powerful, low-profile, spring-diaphragm actuator guarantees positive fail-safe action.
- Splined shaft and actuator linkages, combined with low-friction techniques, contribute to reduced deadband and hysteresis.
- The valve position indicator is large and highly visible.
- The actuator linkage (purge option available) is totally enclosed).

# Numbering System

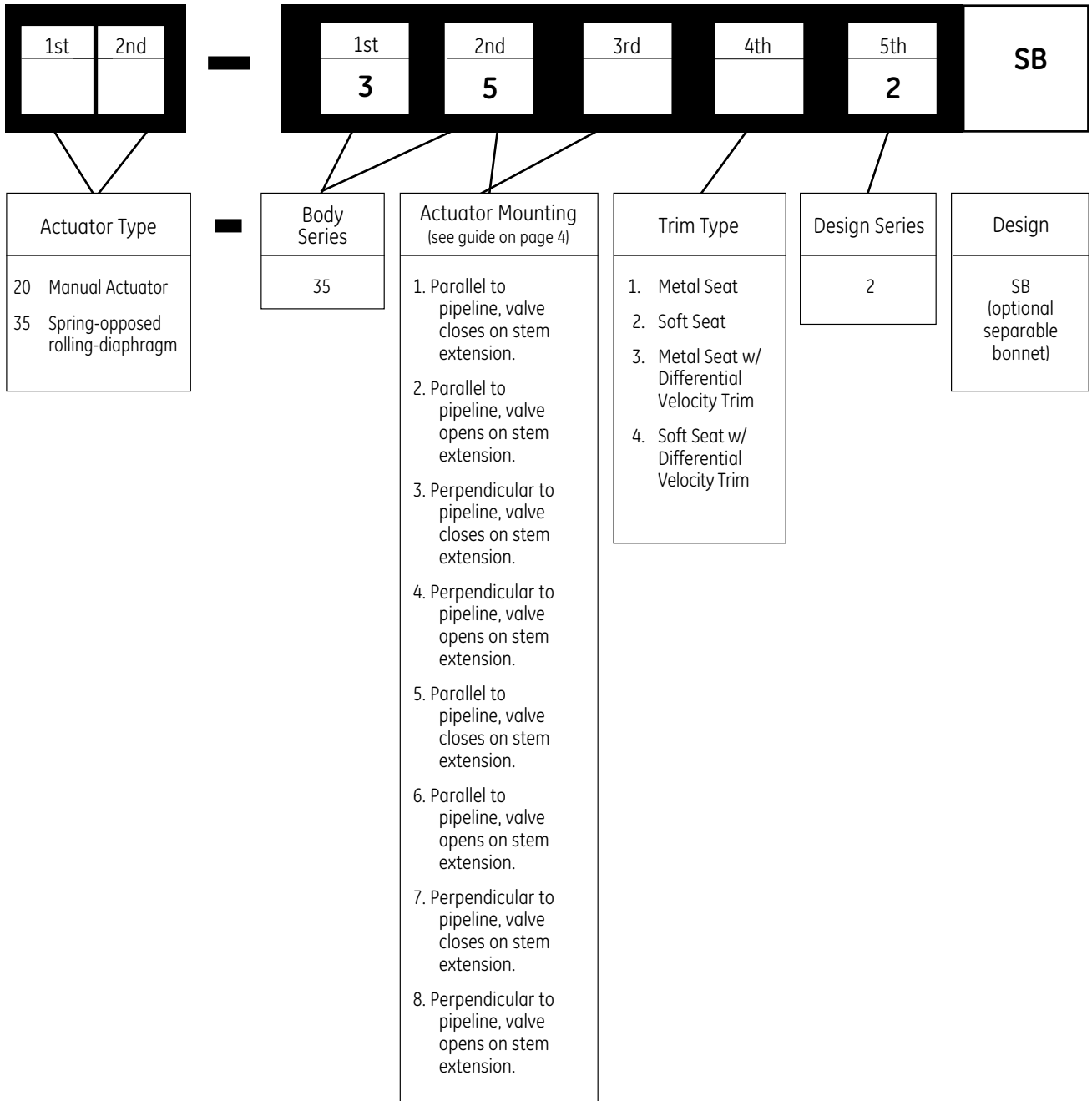

# Actuator Mounting Guide

## CAMFLEX II VALVES (Mounted On Horizontal Pipeline)

3 5 - 3 5 . 0 2

Actuator Position in Relation to Valve Body  
Numbering System : 1 to 8

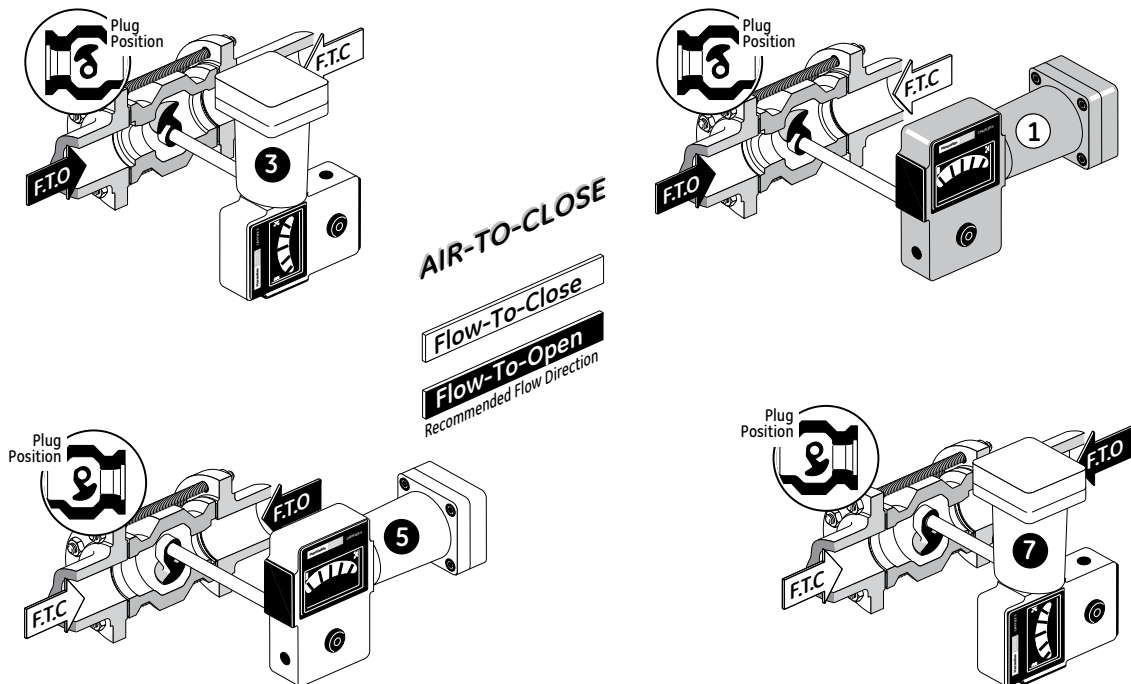
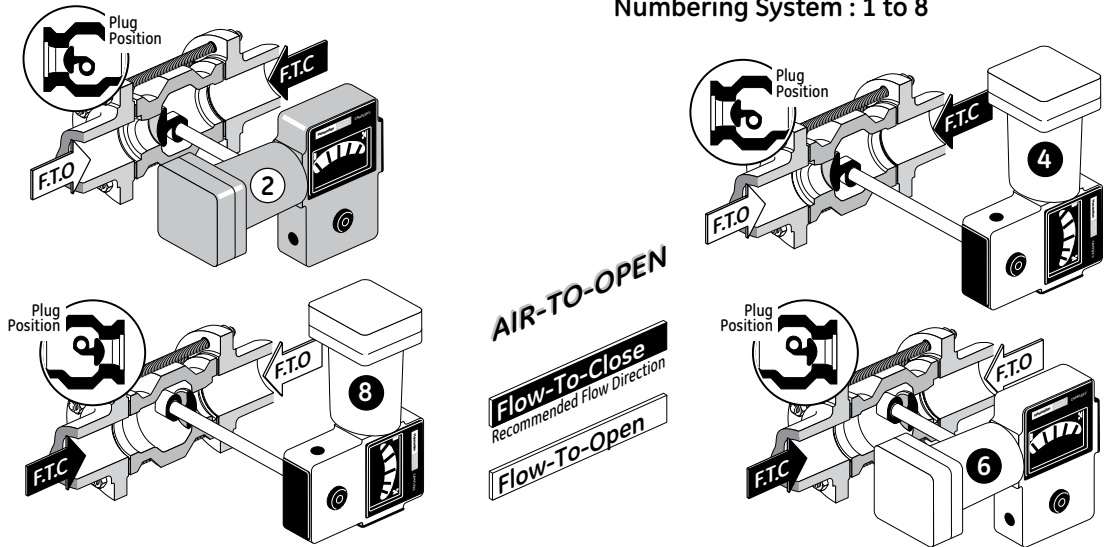

### Notes:

1. It is recommended that the actuator always be mounted as shown above. For other positions, consult your local sales office.
2. Installation is assumed to be in the horizontal pipeline for orientation of the airset and other accessories unless specified on the order.
3. Action and orientation are field reversible without additional parts.
4. Operating efficiencies may vary depending on valve configuration.
5. The above schematic does not reflect every possible body/actuator orientation, but should serve as an effective guide.

# General Data

## • Body

Type:	cast with integral bonnet cast with separable bonnet - 1 in.-8 in.
Flow Direction:	flow to open or flow to close (Differential Velocity Device trim flow to open only)
Materials:	carbon steel 316 stainless steel (flangeless) 316L stainless steel (flanged) in.Hastelloy C in. (1 in.-4 in.) (DN 25-100) <sup>1</sup>
Body Pressure Rating:	ANSI Class 600 (per B16.34) standard (1 in.-12 in.) (DN 25-300) except for flanged construction; valve rating is limited by flange rating
End Connections:	<ul style="list-style-type: none"> <li>• <b>threaded</b> - NPT for ANSI Class 600 rated connections (1 in.) (DN 25)</li> <li>• <b>flangeless</b> - clamps between ANSI Class 150, 300 or 600 rated flanges (flange rating must be specified for 8 in.-12 in. (DN 200-300) valve for locator lug drilling and tapping)</li> <li>• <b>flanged</b> - bolts to ANSI Class 150 or 300 rated flanges (1 in.-12 in.) (DN 25-300) ANSI Class 600 rated flanges (1 in.- 8 in.) (DN 25-200)</li> </ul>

## • Trim

Plug Type:	self-aligning eccentrically rotating
Materials:	1 in.-2 in. (DN 25-100) solid Stellite No. 6 3 in.-4 in. (DN 80 & 100) solid Stellite No. 6 optional 3 in.-12 in. (DN 80-300) 316L stainless steel with hardfaced seating surface 1 in.-4 in. (DN 25-100) in.Hastelloy C in. <sup>1</sup>
Seat Ring:	solid clamped
Materials:	1 in.-12 in. (DN 25-300) 316 stainless steel 1 in.-4 in. (DN 25-100) in.Hastelloy C in. <sup>1</sup> 1 in.-12 in. (DN 150-300) 316 stainless steel with hardfaced seat 1 in.-4 in. (DN 25-100) solid Stellite No. 6 optional 1 in.-12 in. (DN 25-300) 316 stainless steel with PTFE insert (to 450°F), (232°C)*
Retainer:	316 Stainless Steel
Capacity:	full area and reduced capacity in all sizes
Flow Characteristic:	standard trim - linear low flow trim (.036 + .07 factor) - linear (requires SVI) differential velocity device - linear
C <sub>v</sub> Ratio:	standard trim >100:1 low flow trim 15:1 differential velocity device >50:1

1. See materials of construction

\*Not available in .2 factor or Low Flow Trim sizes

## • Actuators

### • Spring-Opposed Rolling Diaphragm

Size:	<ul style="list-style-type: none"> <li>• 4½ in. diameter with 3½ in. (89mm) stroke (1 in.-2 in. valves), (DN 25-50)</li> <li>• 6 in. diameter with 5¾ in. (146mm) stroke (3 in.-4 in. valves), (DN 80-100)</li> <li>• 7 in. diameter with 7¼ in. (184mm) stroke (6 in.-12 in. valves), (DN 150-300)</li> <li>• 9 in. diameter with 7¼ in. (184mm) stroke (6 in.-12 in. valves), (DN 150-300)</li> </ul>
Range:	7-15 psi (1 in.-4 in.), (DN 25-100) 7-24 psi (6 in.-12 in.), (DN 150-300) (7 in. diameter actuator)
	7-24 psi (6 in.-12 in.), (DN 150-300) (9 in. diameter actuator, Air to Close) 8-25 psi (6 in.-12 in.), (DN 150-300) (9 in. diameter actuator, Air to Open)
Air Connection:	¼ in. NPT
Yoke:	cast iron
Bearing:	sealed radial
Auxiliary Handwheel:	solid disk with locking nut 6½ in. diameter (1 in.-4 in. valves), (DN 25-100) 10 in. diameter (6 in.-12 in. valves), (DN 150-300)

### • Manual Actuator

Type:	solid disk with detent anti-rotation device. Continuously connected
Sizes:	<ul style="list-style-type: none"> <li>• 7 in. (178mm) diameter (1 in.-2 in. valves), (DN 25-50)</li> <li>• 8⅞ in. (225mm) diameter (3 in. &amp; 4 in. valves), (DN 80-100)</li> <li>• 16½ in. (410mm) diameter (6 in.-12 in. valves), (DN 150-300)</li> </ul>
Material:	aluminum
Yoke:	cast iron
Bearing:	sealed radial ball

# Ratings and Connections

Valve Size		ANSI Class		
in.	DN	150	300	600
1-2	25-50	Δ ○ ●	Δ ○ ●	Δ ○ ●
3-8	80-200	○ ●	○ ●	○ ●
10-12	250-300	○ ●	○ ●	○

Δ Threaded    ○ Flangeless    ● RF Flanged

**Note:** For flangeless valve sizes 8 in.-12 in., (200mm-300mm) please specify ANSI Class rating.  
Face to Face: ISA S75.04

# General Data

## Standard Spring Diaphragm Actuator Materials

Description	Material
Yoke	Cast Iron
Yoke Covers	Polycarbonate
Spring Barrel	Die Cast Aluminum
Diaphragm Case	Die Cast Aluminum
Piston	Die Cast Aluminum
Diaphragm	Buna-N with Dacron Insert
Piston Rod	303 St. St.
Clevis	Carbon Steel Zinc Dichromate Plated
Clevis Pin	17-4 PH (H1075) St. St.
Lever	Steel With Epoxy Surface
Lever Bearing	PTFE Filament Surface Bonded to Glass Reinforced Plastic Backing
Handwheel and Locknut	Aluminum

## Standard Actuator Characteristics and Travel Times

Actuator Diameter		Diaphragm Effective Area		Actuator Stroke		Travel Time (sec.)	
						Increasing Instrument Signal	Decreasing Instrument Signal
in.	cm	sq. in.	cm <sup>2</sup>	in.	cm		
4½	11.4	14	90	3½	8.9	1.2	2.4
6	15.2	24	155	5¾	14.6	3	6.3
7	17.8	36	232	7¼	18.4	7.6	9.8
9	22.9	75	483	7¼	18.4	17	24

Measured with direct positioner at 30 psi (2 bar) supply  
4700P positioner with tubing size ¼ in.

## Temperature/Seat Leakage

Valve Size		Seat Type	Temp. Range*		Max. Seat Leakage, ANSI FCI/70.2 Class
in.	DN		Min.	Max.	
1-12	25 to 300	Metal	-320°F* (-196°C)	+750°F (400°C)	IV
		Soft Seat**	-320°F* (-196°C)	+450°F (232°C)	VI

\* For Stainless Steel Bodies Only.

\*\*Temperature Limited by Teflon® Seal.

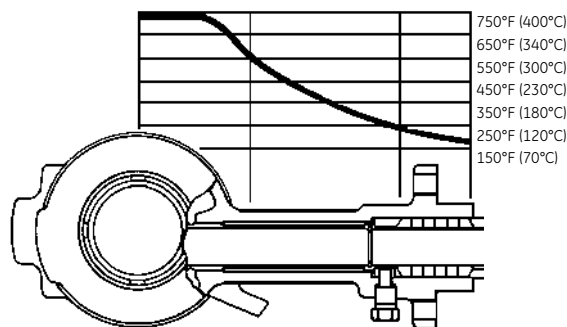

Temperature Gradient Across Standard Integral Bonnet

The ability of the Camflex valve to handle a wide range of process fluid temperatures is due to the long, integrally-cast bonnet. This affords ample radiation surface to normalize the packing temperatures.

## Maximum Rated Flow Coefficients (C<sub>v</sub>) and Critical Flow Factors (F<sub>L</sub>) at Maximum Opening (50°)

Valve Size		Factor	Flow to Open		Flow to Close	
inches	DN		Rated C <sub>v</sub>	F <sub>L</sub>	Rated C <sub>v</sub>	F <sub>L</sub>
1	25	0.036	.5	0.98	.5	0.86
		0.07	1	0.98	1	0.86
		0.2	2.8	0.88	3	0.7
		0.4	5.6	0.88	6	0.7
		0.6	8.4	0.88	9	0.7
		1	14	0.85	15	0.68
		DVD	5			
1.5	40	0.4	13.2	0.88	15.6	0.7
		0.6	19.8	0.88	23.4	0.7
		1	33	0.85	39	0.68
		DVD	12.5			
2	50	0.4	20	0.88	21.2	0.7
		0.6	30	0.88	31.8	0.7
		1	50	0.85	53	0.68
		DVD	18			
3	80	0.4	54	0.88	58	0.7
		0.6	81	0.88	87	0.7
		1	135	0.85	145	0.68
		DVD	48			
4	100	0.4	92	0.88	92	0.7
		0.6	138	0.88	138	0.7
		1	230	0.85	230	0.68
		DVD	78			
6	150	0.4	200	0.88	200	.07
		0.6	300	0.88	300	0.7
		1	500	0.85	500	0.68
		DVD	181			
8	200	0.4	340	0.88	340	0.7
		0.6	510	0.88	510	0.7
		1	850	0.85	850	0.68
		DVD	308			
10	250	0.4	520	0.88	520	0.7
		0.6	780	0.88	780	0.7
		1	1300	0.85	1300	0.68
		DVD	486			
12	300	0.4	700	0.88	700	0.7
		0.6	1050	0.88	1050	0.7
		1	1750	0.85	1750	0.68
		DVD	684			

Note: Low flow trims (.036+.07 factor) require use of SVII II AP, or FVP digital positioners.

# (C<sub>v</sub>) and (F<sub>L</sub>) Versus Travel

Flow Direction: Flow to Open

Flow Characteristics: Linear

ANSI Class: 150 through 600

Sizes: 1 in. through 12 in. (DN 25-300)

Percent of Plug Rotation						10	20	30	40	50	60	70	80	90	100
F <sub>L</sub> Full Area						0.96	0.93	0.91	0.89	0.88	0.87	0.87	0.86	0.86	0.85
F <sub>L</sub> Reduced Area (.6, .4, & .2)						0.96	0.93	0.91	0.89	0.88	0.88	0.88	0.88	0.88	0.88
Valve Size		Orifice Dia.		Act. Stem Travel		Rated C <sub>v</sub>									
in.	DN	in.	mm	in.	mm										
1	25	.321	8.2	3.50	89	0.4	0.8	1.1	1.4	1.7	2.0	2.3	2.5	2.7	2.8
		.500	12.7	3.50	89	0.5	0.9	1.4	2.0	2.7	3.5	4.2	4.8	5.2	5.6
		.579	14.7	3.50	89	0.6	1.3	2.2	3.1	4.2	5.3	6.4	7.2	7.9	8.4
		.718	18.2	3.50	89	0.9	2.1	3.7	5.7	7.8	9.6	11.1	12.4	13.3	14
1½	40	.750	19.1	3.50	89	1.1	2.1	3.3	4.7	6.5	8.4	9.9	11.2	12.3	13.2
		.907	23.0	3.50	89	1.4	3.2	5.1	7.4	10.0	12.7	15.0	17.1	18.6	19.8
		1.125	28.6	3.50	89	2.0	5.0	8.6	13	19	22	26	29	32	33
2	50	1.000	25.4	3.50	89	1.6	3.2	5.0	7.2	9.8	12.6	15.0	17.0	18.7	20
		1.159	29.4	3.50	89	2.1	4.8	7.7	11.2	15.1	19.1	22.7	25.8	28.2	30
		1.437	36.5	3.50	89	3.1	7.5	13.3	20.5	28	34.2	39.8	44.2	47.5	50
3	80	1.500	38.1	5.75	146	4.9	9.4	14.1	20.0	26.5	33.5	39.8	45.4	50.2	54
		1.874	47.6	5.75	146	5.7	12.1	19.6	27.6	37.5	47.9	58.4	68.0	75.9	81
		2.324	59.0	5.75	146	8.8	17.7	29.8	44.5	60.7	78.3	96.2	113	127	135
4	100	2.000	50.8	5.75	146	8.4	16.1	24.0	34.1	45.1	57.1	67.8	77.4	85.6	92
		2.419	61.4	5.75	146	9.7	20.7	33.4	47.0	63.8	81.6	99.4	116	129	138
		3.000	76.2	5.75	146	15.0	30.2	50.8	75.8	104	133	164	193	216	230
6	150	3.000	76.2	7.25	184	18.2	34.9	52.2	74.1	98.0	124	147	168	186	200
		3.629	92.2	7.25	184	21.2	44.9	72.7	102	139	177	216	252	281	300
		4.500	114	7.25	184	32.7	65.7	110	165	225	290	356	419	470	500
8	200	3.797	96.4	7.25	184	22.0	44.2	71.9	107	150	196	241	283	317	340
		4.840	123	7.25	184	31.3	63.6	114	178	246	313	374	425	468	510
		6.000	152	7.25	184	42.8	111	201	316	434	542	639	725	798	850
10	250	4.746	121	7.25	184	33.7	67.6	110	164	230	300	369	432	485	520
		6.050	154	7.25	184	47.8	97.3	175	273	376	478	572	650	716	780
		7.500	191	7.25	184	65.5	170	307	483	663	828	977	1109	1221	1300
12	300	5.780	147	7.25	184	45.3	91.0	148	221	309	403	497	582	652	700
		7.460	189	7.25	184	64.4	131	235	367	506	644	769	875	964	1050
		9.250	235	7.25	184	88.1	228	414	650	893	1115	1315	1493	1644	1750

# (C<sub>v</sub>) and (F<sub>L</sub>) Versus Travel

Flow Direction: Flow to Close

Flow Characteristics: Linear

ANSI Class: 150 through 600

Sizes: 1 in. through 12 in. (DN 25-300)

Percent of Plug Rotation						10	20	30	40	50	60	70	80	90	100
F <sub>L</sub> Full Area						0.94	0.91	0.88	0.83	0.80	0.77	0.74	0.72	0.70	0.68
F <sub>L</sub> Reduced Area (.6, .4, & .2)						0.94	0.91	0.88	0.83	0.80	0.77	0.74	0.72	0.70	0.7
Valve Size		Orifice Dia.		Act. Stem Travel		Rated C <sub>v</sub>									
in.	DN	in.	mm	in.	mm										
1	25	.321	8.2	3.50	89	0.4	0.9	1.2	1.5	1.8	2.1	2.5	2.7	2.9	3
		.500	12.7	3.50	89	0.5	1.0	1.5	2.1	2.9	3.8	4.5	5.1	5.6	6
		.579	14.7	3.50	89	0.6	1.4	2.4	3.3	4.5	5.7	6.9	7.7	8.5	9
		.718	18.2	3.50	89	1.0	2.3	4.0	6.1	8.4	10.3	11.9	13.3	14.3	15
1½	40	.750	19.1	3.50	89	1.3	2.5	3.9	5.6	7.7	9.9	11.7	13.2	14.5	15.6
		.907	23.0	3.50	89	1.7	3.8	6.0	8.7	11.8	15.0	17.7	20.2	22.0	23.4
		1.125	28.6	3.50	89	2.4	5.9	10.2	15.4	22.5	26.0	30.7	34.3	37.8	39
2	50	1.000	25.4	3.50	89	1.7	3.4	5.3	7.6	10.4	13.4	15.9	18.0	19.8	21.2
		1.159	29.4	3.50	89	2.2	5.1	8.2	11.9	16.0	20.2	24.1	27.3	29.9	31.8
		1.437	36.5	3.50	89	3.3	8.0	14.1	21.7	29.7	36.3	42.2	46.9	50.4	53
3	80	1.500	38.1	5.75	146	5.3	10.1	15.1	21.5	28.5	36.0	42.7	48.8	53.9	58
		1.874	47.6	5.75	146	6.1	13.0	21.1	29.6	40.3	51.4	62.7	73.0	81.5	87
		2.324	59.0	5.75	146	9.5	19.0	32.0	47.8	65.2	84.1	103	121	136	145
4	100	2.000	50.8	5.75	146	8.4	16.1	24.0	34.1	45.1	57.1	67.8	77.4	85.6	92
		2.419	61.4	5.75	146	9.7	20.7	33.4	47.0	63.8	81.6	99.4	116	129	138
		3.000	76.2	5.75	146	15.0	30.2	50.8	75.8	104	133	164	193	216	230
6	150	3.000	76.2	7.25	184	18.2	34.9	52.2	74.1	98.0	124	147	168	186	200
		3.629	92.2	7.25	184	21.2	44.9	72.7	102	139	177	216	252	281	300
		4.500	114	7.25	184	32.7	65.7	110	165	225	290	356	419	470	500
8	200	3.797	96.4	7.25	184	22.0	44.2	71.9	107	150	196	241	283	317	340
		4.840	123	7.25	184	31.3	63.6	114	178	246	313	374	425	468	510
		6.000	152	7.25	184	42.8	111	201	316	434	542	639	725	798	850
10	250	4.746	121	7.25	184	33.7	67.6	110	164	230	300	369	432	485	520
		6.050	154	7.25	184	47.8	97.3	175	273	376	478	572	650	716	780
		7.500	191	7.25	184	65.5	170	307	483	663	828	977	1109	1221	1300
12	300	5.780	147	7.25	184	45.3	91.0	148	221	309	403	497	582	652	700
		7.460	189	7.25	184	64.4	131	235	367	506	644	769	875	964	1050
		9.250	235	7.25	184	88.1	228	414	650	893	1115	1315	1493	1644	1750



# (C<sub>v</sub>) Versus Travel

Differential Velocity Device (DVD)  
 Flow Direction: Flow to Open only  
 Flow Characteristics: Linear

ANSI Class: 150 through 600  
 Sizes: 1 in. through 12 in. (DN 25-300)

		Percent of Plug Rotation				10	20	30	40	50	60	70	80	90	100
Valve Size		Orifice Dia.		Act. Stem Travel											
in.	DN	in.	mm	in.	mm										
1	25	0.579	14.7	3.5	89	0.52	1.04	1.88	2.62	3.23	3.76	4.22	4.58	4.84	5.00
1.5	40	0.907	23.0	3.5	89	1.30	2.60	4.69	6.54	8.06	9.41	10.5	11.4	12.1	12.5
2	50	1.159	29.4	3.5	89	1.88	3.75	6.75	9.42	11.6	13.6	15.2	16.5	17.4	18.0
3	80	1.874	47.6	5.75	146	5.00	10.0	18.0	25.1	31.0	36.1	40.5	43.9	46.4	48.0
4	100	2.419	61.4	5.75	146	8.13	16.3	29.3	40.8	50.3	58.7	65.8	71.4	75.4	77.0
6	150	3.629	92.2	7.25	184	18.9	37.7	67.9	94.7	116	136	153	166	175	181
8	200	4.84	123	7.25	184	32.1	64.2	116	161	199	232	260	282	298	308
10	250	6.05	154	7.25	184	50.6	101	182	254	313	366	410	445	470	486
12	300	7.46	189	7.25	184	71.3	143	257	358	441	515	577	626	661	684

Note: The differential velocity device is used for aerodynamic noise reduction. It must be used with .6 factor trim flow to open.

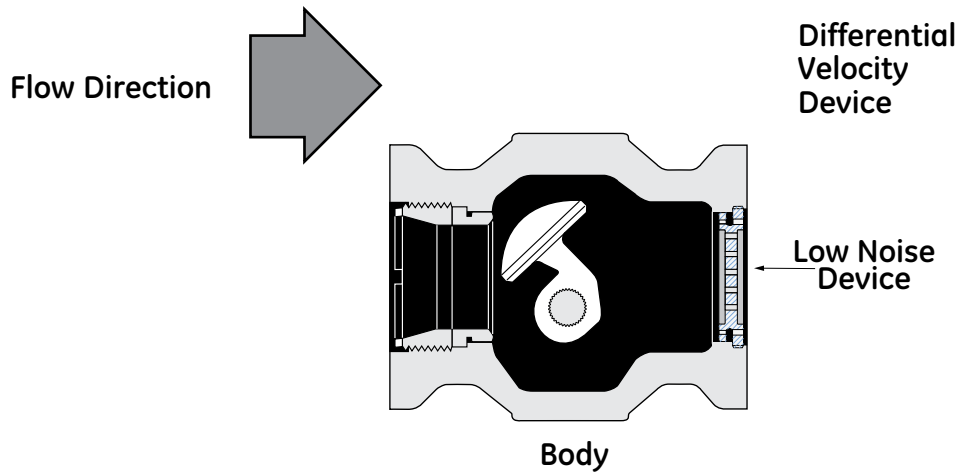

# Materials of Construction

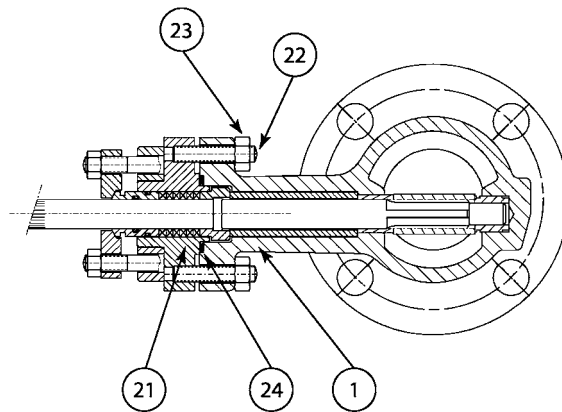

**Body with Separable Bonnet**

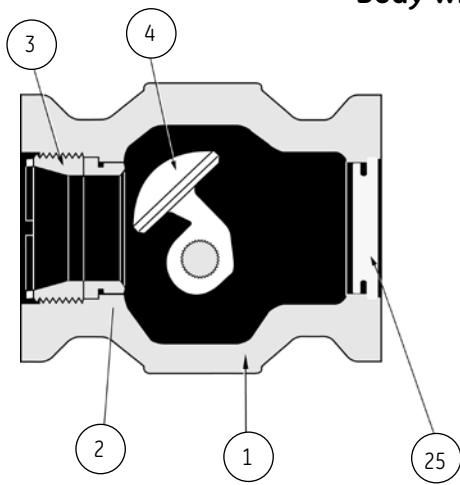

**Body**

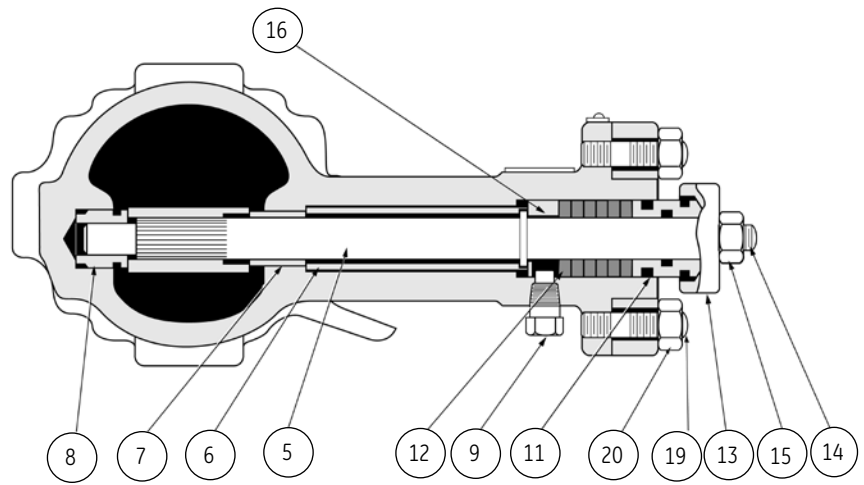

**Body with Integral Bonnet**

## Optional Slurry Package Seal Bushings

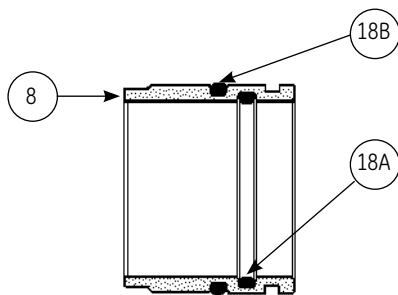

LOWER GUIDE BUSHING

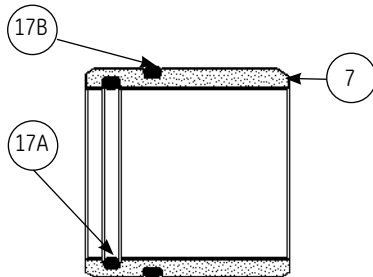

UPPER GUIDE BUSHING

## Standard Camflex Packing Arrangement

### EF Seal

*(Emission Free)*

### Double O-Ring Seal Packing Follower

Fugitive Emission Containment Package for Zero Leakage†

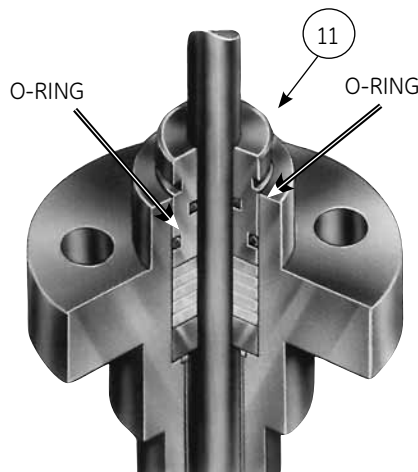

Provides long term reliable extremely low emission shaft seal performance. This economical solution to fugitive emissions won't compromise control performance, and is suitable for use in environmentally sensitive applications.

† Factory Mutual Certified Report

# Materials of Construction

## Carbon Steel Construction

Ref. No.	Temperature Range	Description	-20°F	+400°F	+450°F	+750°F
			-29°C	+205°C	+232°C	+400°C
			Materials			
1		Body	A216 Gr WCC			
2		Seat Ring	316 St. St. ASTM A351 Gr CF8M			
			316 St. St. ASTM A351 Gr CF8M + Stellite Hardfacing Optional			
			ASTM A479 TY 316 St. St. + PTFE 1 in. to 6 in. (DN 25-150)			
			316 St. St. A351 Gr CF8M + PTFE 8 in. to 12 in. (DN 200-300)			
3		Seat Ring Retainer	316 St. St. ASTM A351 Gr CF8M			
4		Plug	Solid Stellite 1 in. to 2 in. (DN 25-50)			
			316L St. St. ASTM A351 Gr CF3M + Stellite Hardfacing 3 in. to 12 in. (DN 80-300)			
5		Shaft	17-4 PH ASTM A564 Gr 630 (H1075)			
6		Spacer	ASTM A312 TY 316			
7		Upper Guide	ASTM A276 TY 440C			
			Upper Guide + O-Ring			
			STELLITE No. 6 + VITON			
8		Lower Guide	ASTM A276 TY 440C			
			Lower Guide + O-Ring			
			STELLITE No. 6 + VITON			
9		Safety Pin	ASTM A479 TY 316			
11		Packing Follower	ASTM A582 TY 303			
			O-Ring Packing Follower			
			VITON			
12		Packing	PTFE + KEVLAR			
13		Packing Flange	Carbon Steel ASTM A105 Zinc Plated			
14		Packing Flange Stud	304 St. St. ASTM A193 Gr B8			
15		Packing Flange Stud Nut	304 St. St. ASTM A194 GR 8			
16		Packing Box Ring	ASTM A479 TY 316			
19		Body Stud	304 St. St. ASTM A193 Gr B8			
20		Body Stud Nuts	304 St. St. ASTM A194 Gr 8			
21*		Bonnet	Carbon Steel A216 GR WCC			
22*		Body / Bonnet Stud	ASTM A 193 Gr B8 Class 2			
23*		Body / Bonnet Nut	ASTM A 194 Gr 8			
24*		Body Gasket	AISI 316L + GRAPHITE			
25		DVD Low Noise Plate	ASTM A479 TY 316			

\* Separable Bonnet version only.

## in.NACE in. Carbon Steel Construction

Ref. No.	Temperature Range	Description	-20°F	+400°F	+450°F	+750°F
			-29°C	+205°C	+232°C	+400°C
			Materials			
1		Body	Carbon Steel A216 Gr WCC			
2		Seat Ring	316 St. St. ASTM A351 Gr CF8M			
			316 St. St. ASTM A351 Gr CF8M + Stellite Hardfacing Optional			
3		Seat Ring Retainer	316 St. St. ASTM A351 Gr CF8M			
4		Plug	Solid Stellite 1 in. to 2 in. (DN 25-50)			
			316L St. St. ASTM A351 Gr CF3M + Stellite Hardfacing 3 in. to 12 in. (DN 80-300)			
5		Shaft	ASTM A479 TY 316 St. St.			
6		Spacer	ASTM A312 TY 316			
7		Upper Guide	STELLITE No. 6			
			Upper Guide + O-Ring			
			STELLITE No. 6 + VITON			
8		Lower Guide	STELLITE No. 6			
			Lower Guide + O-Ring			
			STELLITE No. 6 + VITON			
9		Safety Pin	ASTM A479 TY 316			
11		Packing Follower	ASTM A479 TY 316			
			O-Ring Packing Follower			
			VITON			
12		Packing	PTFE + KEVLAR			
13		Packing Flange	Carbon Steel ASTM A105 Zinc Plated			
14		Packing Flange Stud	304 St. St. ASTM A 193 GR B8			
15		Packing Flange Stud Nut	304 St. St. ASTM A194 GR 8			
16		Packing Box Ring	ASTM A479 TY 316			
19		Body Stud	304 St. St. ASTM A193 Gr B8			
20		Body Stud Nuts	304 St. St. ASTM A194 Gr 8			
25		DVD Low Noise Plate	ASTM A479 TY 316			

**Note:** Standard materials and processes are in accordance with the requirements of NACE specification MR0103. Applications requiring compliance to MR0175-2003 or ISO 15156 must be reviewed by GE.

# Materials of Construction

## Stainless Steel Construction

Ref. No.	Temperature Range Description	-320°F	-58°F	Materials		+400°F	+450°F	+750°F
		-196°C	-50°C	▽	▽	+205°C	+232°C	+400°C
1	Body	Flangeless Body 316 St. St. ASTM A351 Gr CF8M Flanged Body 316L St. St. ASTM A351 GR CF3M						
2	Seat Ring	316 St. St. ASTM A351 Gr CF8M						
		316 St. St. ASTM A351 Gr CF8M + Stellite Hardfacing Optional						
3	Seat Ring Retainer	ASTM A479 TY 316 St. St. + PTFE 1 in. to 6 in. (DN 25-150)						
		316 St. St. A351 Gr CF8M + PTFE 8 in. to 12 in. (DN 200-300)						
4	Plug	316 St. St. ASTM A351 Gr CF8M						
5	Shaft	Solid Stellite 1 in. to 2 in. (DN 25-50)						
		316L St. St. ASTM A351 Gr CF3M + Stellite Hardfacing N°6 3 in. to 12 in. (DN 80-300)						
6	Spacer	316 St. St. ASTM A479 TY 316						
7	Upper Guide	ASTM A564 Gr 630 (H1075) Optional						
	Upper Guide + O-Ring	ASTM A 312 TY 316						
8	Lower Guide	STELLITE No. 6						
	Lower Guide + O-Ring	STELLITE No. 6 + VITON						
9	Safety Pin	STELLITE No. 6						
11	Packing Follower	ASTM A479 TY 316						
	O-Ring	ASTM A582 TY 303						
12	Packing	VITON						
13	Packing Flange	PTFE + KEVLAR						
14	Packing Flange Stud	ASTM A182 GR F304						
15	Packing Flange Stud Nut	304 St. St. ASTM A193 Gr B8						
16	Packing Box Ring	304 St. St. ASTM A194 Gr 8						
19	Body Stud	ASTM A479 TY 316						
20	Body Stud Nuts	304 St. St. ASTM A 193 Gr B8						
21*	Bonnet	304 St. St. ASTM A194 Gr 8						
22*	Body / Bonnet Stud	316L St. St. ASTM A351 Gr CF3M						
23*	Body / Bonnet Nut	304 St. St. ASTM A193 GR B8 CL 2						
24*	Body Gasket	304 St. St. ASTM A194 GR 8						
25	DVD Low Noise Plate	AISI 316L + GRAPHITE						

\* Separable Bonnet version only.

# Materials of Construction

in.NACE in. Stainless Steel Construction

Ref. No.	Temperature Range	-20°F -29°C	+400°F +205°C	+750°F +400°C
	Description	▽	Materials	▽
1	Body		Flangeless Body 316 St. St. ASTM A351 Gr CF8M Flanged Body 316L St. St. ASTM A351 Gr CF3M	
2	Seat Ring		316 St. St. ASTM A351 Gr CF8M 316 St. St ASTM A351 Gr CF8M + Stellite Hardfacing	
3	Seat Ring Retainer		316 St. St. ASTM A351 Gr CF8M	
4	Plug		Solid Stellite 1 in. to 2 in. (DN 25-50) 316L St. St. ASTM A351 Gr CF3M + Stellite Hardfacing 3 in. to 12 in. (DN 80-300)	
5	Shaft		ASTM A479 TY 316 St. St.	
6	Spacer		ASTM A312 TY 316	
7	Upper Guide		STELLITE No. 6	
	Upper Guide + O-Ring		STELLITE No. 6 + VITON	
8	Lower Guide		STELLITE No. 6	
	Lower Guide + O-Ring		STELLITE No. 6 + VITON	
9	Safety Pin		ASTM A479 TY 316	
11	Packing Follower		ASTM A479 TY 316	
	O-Ring		VITON	
12	Packing		PTFE + KEVLAR	
13	Packing Flange		ASTM A182 GR F304	
14	Packing Flange Stud		304 St. St. ASTM A193 Gr B8	
15	Packing Flange Stud Nut		304 St. St. ASTM A194 Gr 8	
16	Packing Box Ring		ASTM A479 TY 316	
19	Body Stud		304 St. St. ASTM A 193 Gr B8	
20	Body Stud Nuts		304 St. St. ASTM A194 Gr 8	
25	DVD Low Noise Plate		ASTM A479 TY 316	

**Note:** Standard materials and processes are in accordance with the requirements of NACE specification MR0103. Applications requiring compliance to MR0175-2003 or ISO 15156 must be reviewed by GE.

# Materials of Construction

Hastelloy C Construction 1 in. to 4 in.

Ref. No.	Temperature Range	-320°F	-58°F	+400°F	+500°F
		-196°C	-50°C	+205°C	+260°C
	Description	▽	▽	▽	▽
		Materials			
1	Body	ASTM A494 Gr CX-2 MW			
2	Seat Ring	HASTELLOY C22			
		HASTELLOY C22 + PTFE			
3	Seat Ring Retainer	HASTELLOY C22			
4	Plug	HASTELLOY C22			
5	Shaft	HASTELLOY C22			
6	Spacer	HASTELLOY C22			
7	Upper Guide <sup>1</sup>	STELLITE No. 6			
	Upper Guide <sup>1</sup>	ALLOY 25			
	Upper Guide <sup>1</sup>	ULTIMET			
	Upper Guide + O-Ring <sup>1</sup>		STELLITE No. 6 + VITON		
8	Lower Guide <sup>1</sup>	STELLITE No. 6			
	Lower Guide <sup>1</sup>	ALLOY 25			
	Upper Guide <sup>1</sup>	ULTIMET			
	Lower Guide + O-Ring <sup>1</sup>		STELLITE No. 6 + VITON		
9	Safety Pin	HASTELLOY C22			
11	Packing Follower	HASTELLOY C22			
	O-Ring	VITON			
12	Packing	PTFE + KEVLAR			
13	Packing Flange	ASTM A182 Gr F304			
14	Packing Flange Stud	304 St. St. ASTM A193 Gr B8			
15	Packing Flange Stud Nut	304 St. St. ASTM A194 Gr 8			
16	Packing Box Ring	HASTELLOY C22			
19	Body Stud	304 St. St. ASTM A193 Gr B8			
20	Body Stud Nuts	304 St. St. ASTM A194 Gr 8			
25	DVD Low Noise Plate	HASTELLOY C22			

**Note:** Standard materials and processes are in accordance with the requirements of NACE specification MR0103. Applications requiring compliance to MR0175-2003 or ISO 15156 must be reviewed by GE.

<sup>1</sup> Material selection must be based on fluid properties and compatibility.

# Dimensions and Weights

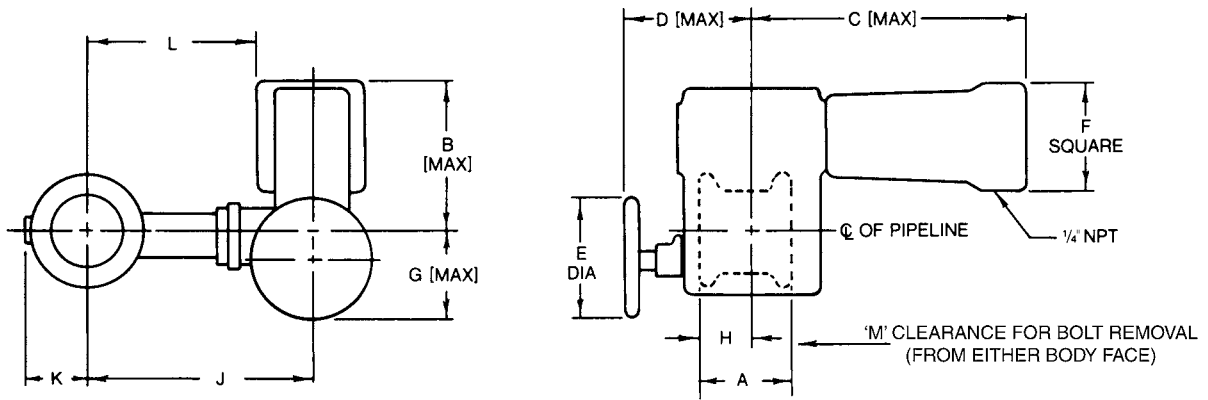

Dimensions (inches)

Valve size		A		B	C	D	E	F	G	H			J	K	L	M			
in.	DN	Threaded ends	Flanged and flangeless							Threaded ends	Flangeless	Flanged				ANSI Class 150 PN 10	ANSI Class 300 PN 16	ANSI Class 400 PN 25	ANSI Class 600 PN 40
1	25	4.00	4.00	6.8	11.5	10.0	6.3	5.5	4.4	2.64	2.64	2.01	8.1	1.5	5.4	6.5	9.0	9.0	9.0
1 1/2	40		4.50	6.9	11.5	10.0	6.3	5.5	4.4		2.44	2.32	9.2	2.0	6.5	6.5	10.0	10.0	10.0
2	50		4.88	6.9	11.5	10.0	6.3	5.5	4.5		2.44	2.44	9.4	2.6	6.7	10.5	10.5	10.5	10.5
3	80		6.50	10.3	16.8	10.5	6.3	6.9	5.1		3.82	3.39	13.1	3.3	9.6	11.8	13.5	14.0	14.0
4	100		7.62	10.4	16.8	10.5	6.3	6.9	5.2		4.17	4.17	14.0	4.3	10.5	13.0	14.0	16.0	16.5
6	150		9.00	13.0	20.4	12.0	10.0	8.6	8.4		5.00	5.00	17.0	5.8	12.7	15.5	16.0	18.5	18.5
8	200		9.56	13.1	20.4	12.0	10.0	8.6	8.5		5.83	5.83	18.5	8.0	14.2	15.5	18.5	19.5	21.0
10	250		11.69	13.2	20.4	12.0	10.0	8.6	8.6		6.57	6.57	22.6	9.9	18.3	20.0	20.5	22.5	24.5
12	300		13.31	13.3	20.4	12.0	10.0	8.6	8.7		7.24	7.24	24.0	10.9	19.7	20.0	22.5	24.8	25.5

Weight (lbs.)

Valve size		Actuator size	Flangeless		Flanged Class 150		Flanged Class 300		Flanged Class 600	
in.	DN		Kg	lbs.	Kg	lbs.	Kg	lbs.	Kg	lbs.
1	25	4.5 in.	17	38	18	41	20	45	20	45
1 1/2	40	4.5 in.	19	43	22	50	24	54	25	55
2	50	4.5 in.	20	45	24	54	27	60	28	63
3	80	6 in.	46	103	52	116	57	129	59	133
4	100	6 in.	54	121	65	146	73	165	86	133
6	150	7 in.	103	232	115	259	131	295	156	351
8	200	7 in.	122	274	140	314	161	363	197	442
10	250	7 in.	178	400	203	456	236	531		
12	300	7 in.	222	499	260	586	307	689		
6	150	No.9	131	295	143	321	159	358	184	414
8	200	No.9	150	337	168	377	189	426	225	505
10	250	No.9	206	463	231	519	264	594		
12	300	No.9	250	562	288	648	335	752		

Specific Dimensions (inches) for the No.9 Actuator

Valve size		B	C	D	E	F	G	L
in.	DN							
6	150	14.69	26.54	12.05	15.75	11.97	11.26	11.02
8	200	14.80	26.54	12.05	15.75	11.97	11.38	12.52
10	250	14.92	26.54	12.05	15.75	11.97	11.50	16.61
12	300	15.04	26.54	12.05	15.75	11.97	11.61	17.99

# Dimensions and Weights

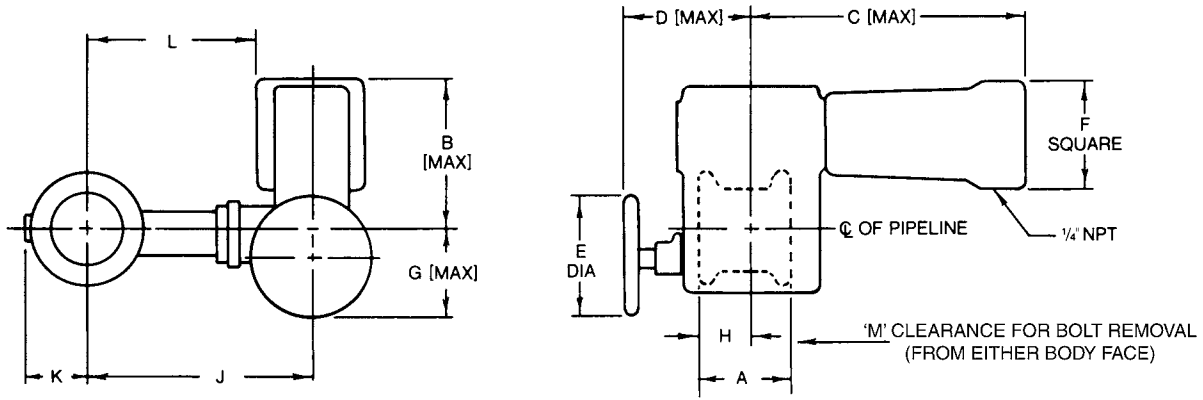

## Dimensions (millimeters)

Valve size		A									H				M				
in.	DN	Threaded ends	Flanged and flangeless	B	C	D	E	F	G	Threaded ends	Flangeless	Flanged	J	K	L	ANSI Class 150 PN 10	ANSI Class 300 PN 16	ANSI Class 400 PN 25	ANSI Class 600 PN 40
1	25	102	102	173	293	253	160	140	112	67	67	51	206	38	137	165	229	229	229
1 1/2	40		114	175	293	253	160	140	113		62	59	234	51	165	165	254	254	254
2	50		124	176	293	253	160	140	115		62	62	239	66	170	267	267	267	267
3	80		165	262	426	266	160	175	130		97	86	333	84	244	300	343	356	356
4	100		194	264	426	266	160	175	131		106	106	356	109	267	330	356	406	419
6	150		229	330	517	306	254	218	213		127	127	432	147	323	394	406	470	470
8	200		243	333	517	306	254	218	216		148	148	470	203	361	394	470	495	533
10	250		297	335	517	306	254	218	219		167	167	574	251	465	508	521	572	622
12	300		338	338	517	306	254	218	222		184	184	610	277	500	508	572	630	648

## Weight (Kg)

Valve size		Actuator size	Flangeless		Flanged Class 150		Flanged Class 300		Flanged Class 600	
in.	DN		Kg	lbs.	Kg	lbs.	Kg	lbs.	Kg	lbs.
1	25	4.5 in.	17	38	18	41	20	45	20	45
1 1/2	40	4.5 in.	19	43	22	50	24	54	25	55
2	50	4.5 in.	20	45	24	54	27	60	28	63
3	80	6 in.	46	103	52	116	57	129	59	133
4	100	6 in.	54	121	65	146	73	165	83	186
6	150	7 in.	103	232	115	259	131	295	156	351
8	200	7 in.	122	274	140	314	161	363	167	442
10	250	7 in.	178	400	203	456	236	531		
12	300	7 in.	222	499	260	586	307	689		
6	150	No.9	131	295	143	321	159	358	184	414
8	200	No.9	150	337	168	377	189	426	224	505
10	250	No.9	206	463	231	519	264	594		
12	300	No.9	250	562	288	648	335	752		

## Specific Dimensions (millimeters) for the No.9 Actuator

Valve size		B	C	D	E	F	G	L
in.	DN							
6	150	373	674	306	400	304	286	280
8	200	376	674	306	400	304	289	318
10	250	379	674	306	400	304	292	422
12	300	382	674	306	400	304	295	457



# DIRECT SALES OFFICE LOCATIONS

## BELGIUM

Phone: +32-2-344-0970  
Fax: +32-2-344-1123

## BRAZIL

Phone: +55-11-2146-3600  
Fax: +55-11-2146-3610

## CHINA

Phone: +86-10-8486-4515  
Fax: +86-10-8486-5305

## FRANCE

Courbevoie  
Phone: +33-1-4904-9000  
Fax: +33-1-4904-9010

## GERMANY

Ratingen  
Phone: +49-2102-108-0  
Fax: +49-2102-108-111

## INDIA

Mumbai  
Phone: +91-22-8354790  
Fax: +91-22-8354791

## New Delhi

Phone: +91-11-2-6164175  
Fax: +91-11-5-1659635

## ITALY

Phone: +39-081-7892-111  
Fax: +39-081-7892-208

## JAPAN

Chiba  
Phone: +81-43-297-9222  
Fax: +81-43-299-1115

## KOREA

Phone: +82-2-2274-0748  
Fax: +82-2-2274-0794

## MALAYSIA

Phone: +60-3-2161-0322  
Fax: +60-3-2163-6312

## MEXICO

Phone: +52-5-310-9863  
Fax: +52-5-310-5584

## THE NETHERLANDS

Phone: +0031-15-3808666  
Fax: +0031-18-1641438

## RUSSIA

Veliky Novgorod  
Phone: +7-8162-55-7898  
Fax: +7-8162-55-7921

## Moscow

Phone: +7 495-585-1276  
Fax: +7 495-585-1279

## SAUDI ARABIA

Phone: +966-3-341-0278  
Fax: +966-3-341-7624

## SINGAPORE

Phone: +65-6861-6100  
Fax: +65-6861-7172

## SOUTH AFRICA

Phone: +27-11-452-1550  
Fax: +27-11-452-6542

## SOUTH & CENTRAL

AMERICA AND THE CARIBBEAN  
Phone: +55-12-2134-1201  
Fax: +55-12-2134-1238

## SPAIN

Phone: +34-93-652-6430  
Fax: +34-93-652-6444

## UNITED ARAB EMIRATES

Phone: +971-4-8991-777  
Fax: +971-4-8991-778

## UNITED KINGDOM

Wooburn Green  
Phone: +44-1628-536300  
Fax: +44-1628-536319

## UNITED STATES

Massachusetts  
Phone: +1-508-586-4600  
Fax: +1-508-427-8971

## Corpus Christi, Texas

Phone: +1-361-881-8182  
Fax: +1-361-881-8246

## Deer Park, Texas

Phone: +1-281-884-1000  
Fax: +1-281-884-1010

## Houston, Texas

Phone: +1-281-671-1640  
Fax: +1-281-671-1735

## California

Phone: +1-562-941-7610  
Fax: +1-562-941-7810



\* Masonellon, Camflex, SVI and FVP are registered trademarks of the General Electric Company. Other company names and product names used in this document are the registered trademarks or trademarks of their respective owners.